

| save | rescue | ems



One-stop shopping

■ made
■ in
■ Germany

2010

IBÖNINGES

Quality since 1903

Welcome to Dönges

You are now holding a copy of the new

| rescue | recovery | assistance catalogue 2009/2010.

On these 400 pages you will find our continuously expanding range of professional and innovative products associated with Fire Brigades, THW and aid organisations.

Please contact us if you have any questions, suggestions or criticisms - we are there for you at all times.

I am looking forward to good, partnership-like collaboration...



A handwritten signature in blue ink that reads "T. Pletsch". The signature is stylized and includes a large, sweeping flourish above the name.

Your Thomas Pletsch
(fourth-generation company owner)



1 Personal equipment

Hatchets/Knives/	
Multi-Tools	16-29
Helmet lamps and	
Working lamps	30-52
Body protection	53-69
Ropes/Belts	70-72
Belts/Holsters/Bags	73-77



2 Tools

Portable tools	80-108
Hooks/shovels/brooms	109-119
Toolboxes	120-148
Power tools	149-160
Equipment for technical assistance	161-180
Auxiliary equipment	181-189



3 Light/Energy

Batteries/Rechargeable batteries	192-193
Lighting/Tripods	194-200
Cable reels	201-205
Distributors	206-210
Cables/connectors	211-219
Generators	220-225



4 Warning materials

Traffic cones/ folding signals	2228-232
Warning materials	233
Vests	234-235
Light sticks/ Warning lights	236-241
Cordoning materials	241-243



5 Emergency medicine

Respiration equipment	246-255
Medical equipment	256-261
Immobilisation	262-270
Transport	271-279
PAX® products	280-291
First Aid equipment	292-303



6 Disaster relief

Quick erection tents	306-315
Tent accessories	316-322
Food and drink/ accommodation	323-333
Vehicle loads disaster relief	334-339



7 Environmental protection

Gas warning devices	342-344
Flood/water protection	345-349
Sealing materials	349-351
Decontamination	352-357



8 Extinguishing equipment

Mist extinguishing system NLS	360-363
Extinguisher	364-365
Fire blanket	365
Smoke detector	366
Key	367-369
Hose bridges	370-371



Johann Dönges started to manufacture files and rasps in Remscheid in 1903.

The majority of the products were initially sold in Remscheid and Solingen. The customer base expanded continuously in the 1920's.

The owner's son, **Heinrich Dönges**, joined the company in 1949. He established a range of quality tools in parallel to the file manufacturing facility. After the death of Johann Dönges in 1962, file production was eventually wound down in 1967. **Marion Pletsch**, the founder's granddaughter, took over the company in 1971.

Business with the postal service, the railways, the armed forces and the Home Office was built up during this time.

The Fire Brigade equipment area emerged from collaboration with the Home Office in the early 1990's.

Wolfgang Schulz and **Thomas Pletsch** have been managing the company since 1999.



More and more products are being developed and manufactured in-house nowadays. As Germany's tool industry centre, the city of Remscheid has always provided us with extremely good support.



As we all know, a company's employees are its biggest asset.

You will be dealt with by more than sixty committed men and women. Having a personal relationship and a good working climate are extremely important to us.

Since 2003 we have had a modern building in a good location with a 2500 m² industrial site, a 1000 m² office area and 4000 m² of undeveloped land. We started to equip the office building in 2009, and are therefore well equipped for future requirements.



Your advisory team:



Carina Tschenker
Fire Brigade Products
Phone: +49 (0) 21 91/56 26-112
Fax: +49 (0) 21 91/56 26-199
E-mail: cm@doenges-rs.de



Klaus Schneider
Emergency Products
Product Manager
Phone: +49 (0) 21 91/56 26-119
Fax: +49 (0) 21 91/56 26-199
E-mail: ks@doenges-rs.de



Stefan Gowitzke
Disaster Relief Products
Phone: +49 (0) 21 91/56 26-111
Fax: +49 (0) 21 91/56 26-199
E-mail: sg@doenges-rs.de



Jürgen von Kampen
UK Lights Sales
Phone: +49 (0) 21 91/56 26-114
Fax: +49 (0) 21 91/56 26-199
E-mail: jvk@doenges-rs.de



Klaus Trusheim
Sales Manager
Phone: +49 (0) 21 91/56 26-115
Fax: +49 (0) 21 91/56 26-199
E-mail: kt@doenges-rs.de



Wolfgang Schulz
Managing Director
Phone: +49 (0) 21 91/56 26-0
Fax: +49 (0) 21 91/56 26-199
E-mail: ws@doenges-rs.de

Directions

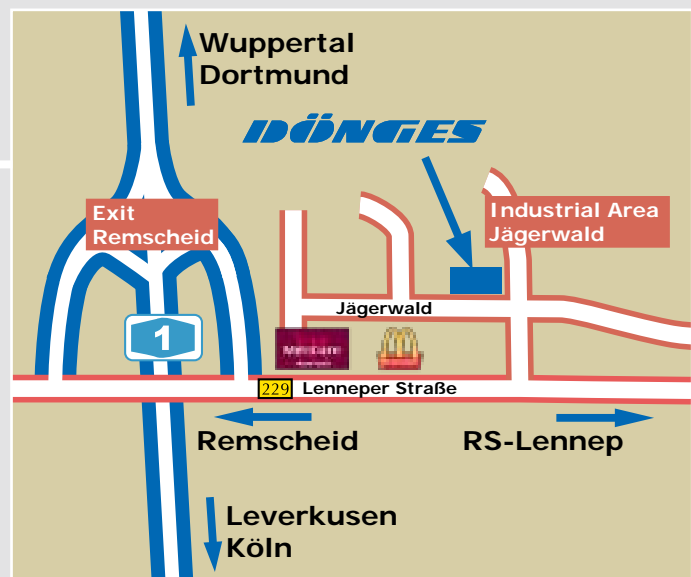

Manufacturing and trade

One of our main strengths is system delivery with entire product ranges.

Regardless of whether you want to load a standard vehicle or have decided on a completely customised system, we can supply all of the components from a single source.

In order to make this possible, as well as trade and master distribution many products are manufactured and assembled in house.

For example, this includes Dönges tool sets, lighting products and cables.

Many products are also manufactured exclusively for us by well-known manufacturers.

You can recognise the exclusive products in the catalogue from the logo:

DÖNGES
exclusive

Individual lettering
on request.



A

Abseiling spider	275
Accident cover	279
Accommodation tent	315
Adapter cable	214
Adhesive	
fabric tape	189
tape	189
tape dispenser	189
Adult ventilation bag	246
AED	259-260
Air	
bulb masks	248
distributor	320
hose	317, 320
Airbag securing system	170
Airshelter	306-312
Alkaline battery	192
All-purpose expansion plug	186
All-rubber	
cable reels	201-205
distributor	208-210
drive-over ramp	178
Aluminium	
basket	136
box	129, 133-136
hose bridge	370
partition wall set	131
Ambulance blanket	278
Angle grinders	155
Angular plug	218
Army canister	182
Ashlar fork	116
Attaché insert	130
Automatic glass punch	29, 168
Automatic knife	18
Axe	84, 87-88, 112

B

Backboard	264-265, 267
Bag	34, 71, 75
for knife	23
Ballast tank	307, 313
Basin	175, 184, 353, 355
Basket	136
Basket stretcher	274-275
Battery	192
Beaker	326
Beer tent set	332
Bell	95-96
Belt	70, 73
bag	34
cutter	25-27, 168
hose holder	367
knife	25-27, 168
system	266
Bench	332
Binding	
rope	181
wire	188
Bit box	150
Bitting gauge	100

Blacksmith's chisel	80
Blanket	278, 331
bag	331
set	169
Blood pressure measuring device	294
Blower	307, 317
Bolt cutters	103, 112
Boots	61
Boston splint	270
Bow saw	108
Box	122-124
Breathing	
air cylinder	77
protection holster	73-74
protection mask	54
Broom head	117
Brooms	117-118
Bucket	183
Bucket pump	362
Bung wrench	106
Buster tool	85

C

Cable	216
hoist	173-174
reel	201-205
ties	188
Calibration unit	342
Camp bed	330
packing sack	331
Camping stove	327
Canisters	182, 329
Canvas bucket	183
Cap knife	25
Capnograph	258
Care equipment trailer	336
Car first aid kit	294
Carpenter's crowbar	92
Carrying	
belt	367
chair	271
cloth	276-277
rope	72
Case	125-128
CEE plug-in device	219
Ceiling hooks	109-110
Cervical support	263
Chair	332
Chalk	
gravity marker	76
marking spray	243
Channel support	179
Charger	193
Chemical protection	
gloves	60
overall	62-64
ChemLights	236-240
Child respiration bag	247
Child's cuff	294
Chimney tool box	142
Chisel hand guard	82
Chisel mallet	153-154

Chisel SDS-max	154
Circular sling	175
Clamping device	96
Claw hammer	83
Cleaning cloth	348
Clearing	
shovel	349
trough	175, 184
Clipboard	302-303
Clip lifter	107
Clothes hanger	68-69
Clothing	
bag	75
scissors	292
Club hammer	81
Coffee	
container	328
cup	326
Cold light laryngoscope	252-253
Collection basin	355
Combination	
pliers	101
spanner	105
Company first aid box	295
Compass	76
Composite clamp	188
Compressed air tent	308-312
Connecting	
cable	215
socket	218-219
tarpaulin	307, 313
Construction	
strut	179
wrench	100
Consumables box	145
Continuous heater	355
Cooker	327
Cooking	
crockery	325
pot	327
spoon	324
Copper hammer	81
Cordoning	
chain	243
equipment set	241
post	106
tape	243
Corner pipe clamp	102
Corpse	
blanket	279
cover	279
Coupling spanner	365-366
Cover lifter	366
Cramp iron	188
Crockery	323-325
Crocodile	369
Cross-cut saw	108
Crowbar	92
Cruiser Mate	302
Cups	326
Cutlery	324
Cutter	161-162
Cutting disks	155

Cutting torch	163
Cylinder binding belt	349

D

Decontamination	
basin	353-355
circle	352
mixer	354
pump	354
shower	350-352
Decorative hatchet	16
Defibrillator	259-260
Delta box	206-207
Demolition hammer	153-154
Diagonal cutting	
lead sealing pliers	101
nippers	101
Diamond cutting disk	156
Digging shovel	114
Disaster bag	288
Discharge	182
Display tray	326
Disposable	
carry blanket	277
glove	60
patient blanket	278
protective clothing	62
Distance meter	160
Distributors	206-210
Diver's lamp	42-45
Door ram	94
Double	
canisters	182
chamber hose	345
head stethoscope	294
open ended spanner	105
ring spanner	105
Dowels	186-187
Drinking water canister	329
Drinks container	328
Drive-over	
plank	178
ramp	178
Driver's logbook	300, 301
Dry	
box	122
wall screws	186
Dung hoe	116

E

Ear plugs	53
Earthing	
lead	225
Espike	225
Easy-Zip-It	291
Eating	
crockery	323
cutlery	324
Eco Boom	345
Edge	
protector	175
rider	175

Elaston broom head	117
Electric	
heating fan	318
tool box	141
Emergency	
hammer	27, 168
pump set	344
rucksack	282-286, 297-299
Endotracheal tube	254
Engineer's hammer	80
Environmental damage box	146
Equipment	
trailer	335-337
vehicle	335
Euro box	129
Exhaust hose	225
Expansion plug	186
cable	212-214
Externally mounted equipment plug	217-219
Extinguishing	
blanket	363
blanket container	363
lances	361
Eyewash bottle	292

F

Fan filter suit	64
Feeding line	215
Fibre glass	
axe	112
bolt cutters	112
ceiling hooks	110-111
fire rake	113
ripping hook	111
Field rescue equipment	285-286
Film	348
Filter	65
Filtering shovel	349
Finger sensor	257
Fire	
beater	363
blanket	363
bucket	183
detector	364
Portable fire extinguishing spray	362
rake	113
box	133-136
Fire Brigade	
axe	87-88
chrome plated hatchet	16
floodlight	194-196
halogen floodlight	194-196
hatchet	16
karabiner	72
knife	17-20
rope	71
rope bag	71
Rucksack	75
safety belt	70
spades	115
Fire Brigade	
suction pump	342-343

Fire Brigade	
vacuum	343
warning device bag	76
FireStay support	180
First Aid	
bag	289
box	294-296
kit	294-296
scissors	292
Fix-o-mat	118, 119
Flag	233
Flare set	241
Flashing light	230
Flat	
chisel	82
sack	184
Floodlight	194-196
Fluid bag	355
Folding	
container	355
direction board	231
signal	231-232
traffic cone	229-230
chair	332
spade	115
Food	
container	328
storage box	326
Foot-operated suction pump	255
Force rescue equipment	85
Forest	
fire beater	363
worker kit	53
Frame tent	315
Funnel	183

G

Gable connector	15
Gas	
cooker	327
cylinder	316
heating fan	318
Gedore tool assortment	147
Generator	220-224
Glass	
lifter	167
management set	167
master	166-167
master pocket rescue tool	17
punch	29, 168
saw	166-167
Goggles	54
Gojak	164
Gravity knife	18
Greifzug	173-174
Grinding disk	155
Ground-level hydrant wrenches	365
Guedel tubes	254
Gully cover	346-347
cover lifter	366
stop	347

H

Halogen floodlight	194-195
Hammer	
club hammer	81
copper	81
drill	151-154
drill accessory kit	152
emergency	168
engineer's	80
for NLS	360
manhole cover	83, 367
roofing	80
rubber	81
sledge	80
wood	81
Handheld	
floodlight	51-52
glove	55-60
glove clip	58
guard for chisel	82
hatchet	83
lamp	31-33, 38-47, 51-52
saw	108
suction pump	255
tape dispenser	189
HangAir	68
Hatchet	16, 83-84
decorative	16
fire Brigade	16
protective bag	16
Hay fork	116
Headlamp	48-50
Head support	267
Heater	318-321
Heating unit	321
Helmet	
holder	35-37
lamp	31-33, 48-50
Hemp	347
rope	181
Hexagon	
nuts	187
wood screws	186
HID floodlight	196
High altitude rescue rucksack	287
High voltage cable	212-214
HMS karabiner	72
Hoe	116
Hoist	173-174
Hoisting strap	175
Holder for cordoning tape	242
Holstein sand shovel	114
Holster	34, 73-74
for knife	23
reel-in	23
Hooligan tool	90-92
kit	94
Hose	
bridge	368-369
carrying belt	367
holder	367
Hotbox	355
HQI floodlight	196

Hydrant spanner	365
Hydrophore pump	354
Hygiene module	329

I

Identification vest	235
Inducer	354
Inflatable tents	306
Information sign for AEDs	261
Infusion tripod	272
Inner pocket	290
Inspection lamp	40
Intubation bag	253
Iron wire	188

J

Jig saw	157-159
Joist hanger	187

K

Kangaroo bag	288
Karabiner	72
Kelly tool	91
Kitchen hatchet	83
Knife	
automatic	18
bags	24
belt	25-27, 168
cap	25
chain	24
Fire brigade	17-20
glass master	17
holster	23
PRT	17
RT-I	18
RT-III	20
sheath	23
spiral cable	24
Kuhfuss	92

L

Ladder	165
Ladle	327
Lamp tripod	197-198
Laryngoscope	252-253
Larynx mask	254
Laser distance meter	160
Lead sealing pliers	101
Leak stop	347
Leaning ladder	165
Life hammer	168
LightShapes®	239
Light stick	236-240
Lithium battery	192
Loadout case	126-128
Lock	
picking tool box	97, 143
picks	94
set	131

Low voltage generator	220-224
-----------------------	---------

M

Magnetic clamp	225
Manhole	
brace	179
cover	346-347
Cover hammer	83, 367
Manoeuvring aid	164
Marking	
chalk	76
spray	243
Marquee set	332
Marshalling stick	240
Matador	101
Matches	241
Mazzoni	347
McLeod tool	113
Medical	
box	294-296
Rucksack	282-286, 297-299
Trailer	335
Megaphone	332
Metal	
bow saw	107
box	148
profile cylinder lock	100
vapour discharge lamp	196
Mist extinguishing system	358
Mixer	354
hooligan tool	93
organizer	301
pocket	74
tool	21-22
Multifunction	
axe	84-85
hatchet	84
hooligan tool	90
spanner	100
Multipurpose	
bucket	183
cable	165
hoist	173-174
rope	71

N

Nails	186
Neck brace	263
NiMH battery	193
Non-sparking tools	
bung wrench	106
chisel	82
club hammer	81
corner pipe clamp	102
coupling spanner	366
engineer's hammer	80
pickaxe	116
screwdriver	107
slip joint pliers	102
spades	115
square point shovel	114

Non-sparking tools			
stillson pipe clamp	102		
tool set	147		
Nupla-			
axe	112		
bolt cutters	112		
ceiling hooks	110-111		
fire rake	113		
ripping hook	111		
Nurse's stethoscope	294		
Nut box	104		
Nuts	187		
O			
Oil			
binding cloth	348		
block	345		
heating fan	319-321		
One-man door ram	94		
Open end spanner	105		
Opening tool	95-99, 143		
Operations			
head of operations bag	75		
bag	288		
vest	235		
Overall	62-63		
Oxygen			
box	129		
box (MANV)	251		
cylinder	77, 249		
reservoir	247		
supply bag	249		
P			
Panel saw	108		
Parallel vice	101		
Partition	130-131, 313-315		
Passenger airbag safety catch	171		
Patient blanket	278		
PAX	280-290		
PEEP valve	247		
PE flat sack	184		
Percussive Rescue Tool	93		
Perforated			
bracket	187		
plate	187		
Personnel Marker Light	240		
Petrol canister	182		
Plassava broom head	117		
Pick	116		
Pickaxe	116		
Pick set	94		
Pieces of wood	176		
Piercing saw	108		
Pillow	278		
Pinching bar	92		
Pin punch	82		
Pioneer shovel	114		
Pipe clamp	102		
Pitchfork	116		
Plank	177-178		
Plasma cutter	161-162		
Plastic fuel canister	182		
Plastic shovel	115		
Plate	323		
Platform	164		
Pliers			
combination	101		
corner pipe	102		
pipe	102		
slip joint	102		
Plug	219		
Pneumatic tent	308-312		
Pocket			
clip	34		
knife	24		
rescue knife	17-20		
rescue tool	17		
Polyamide rope	181		
Polyethylene film	346		
Portable			
forest fire spray	362		
spray	362		
workshop lamp	52		
Post wrench	106		
Power			
distributor	206-210		
socket strip	207		
PP shovel	115		
Practice dummy	333		
Press-in dowel	187		
Pressure			
compressed air filling kit	316, 353		
reducer	250		
tents	308-312		
Pressurised gas cylinder	316		
Presswater pump	354		
Protective bag for axe	88		
PRT			
kit	93		
tool	17		
Pry axe	84		
Prying tool	84		
PTFE sealing tape	347		
Pulaski axe	112		
Pull clamp	188		
Pulling device	96		
Pull-in sock	61		
Pulse oximeter	256-258		
Pump	344, 354		
Pump set	344		
Punch	82		
Q			
Quick lift	180		
R			
Rain			
proof clothing	67		
proof jacket	67		
proof trousers	67		
Ram	94		
Ratchet box	104		
tightening belt	181		
Reanimation board	261		
Rechargeable			
battery	193		
floodlight	52, 199, 200		
hammer drills	151		
jig saw	157		
portable floodlights	51		
redi mate LED	303		
redi rite	302		
screw driller	149-150		
screwdriver	149-150		
Reel-			
in sheath	23		
up holster	23		
Rescue			
axe	86		
blanket	276-277, 279		
board	264-267		
cloth	276-277		
corset	263		
disc	156		
hatchet	84, 85		
knife	17-20, 27		
line	71		
mallet	27, 168		
platform	164		
rucksack	297-299		
scissors	28, 293		
stretcher	264-267		
tool	18-20, 86		
Respiration bag	246-247		
Res-q-me	27		
Reusable crockery	323		
Rib nails	186		
Ring spanner	105		
Ripping hook	111		
Road sweeping broom	117		
Roller	177		
Roofing hammer	80		
Rope	71, 181		
bag	71		
hose holder	367		
Rubber			
cable	216		
hose bridge	368-369		
mallet	81		
squeegee	117		
Rucksack	75, 282-286, 297-299		
S			
Safety			
belt	70		
blanket set	169		
boots	61		
cable	211		
cap	219		
clothing	67		
contact connector	218		
contact socket	217-218		
glove	60		

S

Safety	
goggles	54
helmet	53
operations bag	16, 88
overall	62-64
voltage tester	160
Sand	
plate	178
shovel	114
Saunders	302
Saw	
blade	158
bow saw	108
compass saw	108
handheld	108
long saw	108
metal saw	107
tree saw	108
Scissors	28
Scoop stretcher	271
Screw driller	149-150
Screwdriver	107, 149-150
Screws	186
SDS-max chisel and drill	154
Sealing	
hemp	347
paste	347
plug set	349
set	145, 348
tape	347
wedge set	348-349
Secretion pump	255
Serving	
dish	325
spoon	324
Set of	
lock picking tools	95-99
wooden supports	177
Shackle	185
Shaft	
cover	346-346
cover lifter	366
hook	366
Shaped wood set	176-177
Sheet metal	
fuel canister	182
ripper	93
Shoulder belt holster^t73	
Shovel	
bavarian	114
digging	114
pioneer	114
PP	115
sand	114
square point	114
Shower	350-352
Sickle spanner	366
Side dish	325
Signalling torch	47
Signal vest	234
Sign stand	242
Silicone mask	248

Single-handed knife	18-19
Skein	347
Sledge hammer	80
Sling	70
Small part box	131
Smoke detector	364
Snapak	303
SnapLights™	239
Socket	61
set	217-218
set	104
SOS Rescue Tool Kit	86
Soup bowl	323
Spades	115
Spare filter	65
Spar protector	169
Special	
glass centre punch	29, 168
hammer	360
Speedclip Safe	266
Spider strap	266
Spike	242
Spill bag	345-346
Spinal board	264-267
Spiral cable	24-25
Splint	270
Splitting	
hammer	89
wedge	89
Spray	362
Spring	
centre punch	29, 168
glass centre punch	168
Square point shovel	114
Squeegees	117
Squeegee system	164
Stacking	
box	120
case	121
Stand for signs	242
Steel winch	179
Stethoscope	294
Stillson pipe clamp	102
Stop chain	176
Storage stand	273
Stretcher	272
storage stand	273
Strong wind	
flare set	241
matches	241
Suction	
catheter	255
lifter	167
pump	255, 269, 342-343

T

Table	332
Tarpaulin	346
Task force tent	306-312
Tea canister	328
Team tent	315
Teflon tape	347

Telescopic	
ladder	165
tripod	197-198
Tension belt	181
Tent	
fan	307, 317
frame	315
heater	318-321
light	322
permanent fan	306
pneumatic	308-312
pressure tent	308-312
team	315
Thermal blanket	278
Thermophore	328
Threaded bar	187
Three-way distributor	206-207, 361
Timber	177
TNT tool	91
Tool	
box	129, 133-136, 148
box, metal	138-139
box, wood	140
cabinet	147
case	129, 133-136, 148
set	138-140, 147
Torch	31-47
Towing cable	185
Traffic	
accident box	144
cone	228-230
Transport	
basket	136
crate	129, 133-136
roller	177
stacking box/case	120
Tray	272
Tree saw	108
Tripod	197-198
Tuff Writer	302
Turtle	178

U

UK lamp	31-45
UltraBox	123-124
UltraCase	125
Underground hydrant wrenches	365
Unilite head	34
Universal	
blanket	278
charger	193

V

Vacuum	342-343
mattress	268-269
rails	270
VDE toolbox	141
Vehicle	
bracket	181
first aid kit	294
flashing warning lights	233

Vehicle manoeuvring aid	164
Ventilation mask	248
Vice	101
Voltage tester	160

W

Waders	67
Wall cabinet for AEDs	261
Warm air hose	320
Warning	
device bag	76
flag	233
flashing lights	233
lamp	34
operations vest	234
tape	243
triangle	233
Washers	186
Wasserkuppe	282-285
Waste	
container	184
pump	354
sack	184
water pump	354
Water	
canister	329
pump pliers	102
squeegee	117-119
Watertight	
box	122-124
case	125-128
Wax marking chalk	76
Wedge	89
Welder's	
gloves	59
safety goggles	54
Westcoast bar	91
Winch	179
support	180
Window	
breaker	27
element	314
wiper	119
Wire	188
Wire	
cutters	103
pins	186
wool	348
Wood-	
axe	88
connector	187
hose bridge	368
mallet	81
plug set	349
screws	186
wedge set	348-349
Wooden supports	176
Woollen blanket	331
Working	
glove	55-59
lamp	31-33, 38-52
light	194-196, 199-200, 322

Working	
platform	164
rope	71
Workplace floodlight	199-200

Z

Zarges box	129-136
Zieh-Fix	96-99, 143
Zip fastener extension	291

DIN

DIN 338 Twist drill	152
DIN 571 Wood screws	186
DIN 838 Ring spanner	105
DIN 934 Nuts	187
DIN 976 Threaded bars	187
DIN 1041 Engineer's hammer	80
DIN 1042 Sledge hammer	80
DIN 1052 Wood connector	187
DIN 1151 Nails	186
DIN 3110 Open end spanner	105
DIN 3113 Combination spanner	105
DIN 3222 Cordoning post	106
DIN 3223 Hydrant spanner	365
DIN 4071 Plank	177
DIN 4124 Channel brace	179
DIN 5107 Blacksmith's chisel	80
DIN 5128 Rubber mallet	81
DIN 5131 Hatchet	83
DIN 5231 Slip joint pliers	102
DIN 5241 Edge pliers	101
DIN 5244 Combination pliers	101
DIN 5265 Screwdriver	107
DIN 5299C Fire brigade karabiner	72
DIN 6450 Pin punch	82
DIN 6453 Flat chisel	82
DIN 6458 Punch	82
DIN 6473 Bow saw	107
DIN 6475 Club hammer	81
DIN 7239 Roofing hammer	80
DIN 7244 Hand saw	108
DIN 7250 Punch	152
DIN 7258 Piercing saw	108
DIN 7294 Woodcutting axe	88
DIN 7355 Steel winch	179
DIN 7462 Wooden mallet	81
DIN 7961 Cramp irons	188
DIN 9021 Washers	186
DIN 13024 Stretcher	272
DIN 13044 Belts	272
DIN 13155 First Aid	298-299
DIN 13157-C First aid kit	295
DIN 13164-B Car first aid kit	294
DIN 13169-E First aid kit	295
DIN 14060 Basin	184
DIN 14142-K First aid kit	134, 296
DIN 14405 Bucket pump	362
DIN 14572 Exhaust hoses	225
DIN 14640 Standard journal	197-198
DIN 14683 Tripod	198
DIN 14685 Power generator	221

DIN 14800-4 Chimney set	134, 142
DIN 14800-5 Multipurpose hoist	134, 173-174
DIN 14800-9 Tool kit	135-140
DIN 14800-10 Seal set	135, 145, 348
DIN 14800-11 Lifting cushion accessories	135
DIN 14800-12 Lock tools	97, 135, 143
DIN 14800-13 Road accident	135, 144
DIN 14800-14 Consumables	136, 145
DIN 14800-15 Environmental damage	136
DIN 14800-BS Cutting torch	163
DIN 14800-DK	135, 145
DIN 14800-HZK	135

EN

EN 131 Ladders	165
EN 166 Eye protection	54, 144
EN 169 Welding protection	54
EN 352 Hearing protection	53
EN 388 Gloves	56-59
EN 397 Industrial helmets	53
EN 397 Safety helmet	53
EN 471 Warning clothing	67, 234
EN 795 Anti-fall protection	70
EN 1492 Slings	173-175
EN 1731 Eye protection	53
EN 1865 Stretchers	263-277
EN 1869 Fire blanket	363
EN 12941 Respiratory devices	64
EN 14605 Protective clothing	
against liquid chemicals	64
EN 50146 Cable ties	188
EN 60309 Plugs/couplings	219
EN 61316 Cable reels	201

Impression:

Issued by: Dönges GmbH & Co. KG
Jägerwald 11, D-42897 Remscheid

Copyright: Dönges GmbH & Co. KG

Editorial team: Stefan Gowitzke, Thomas Pletsch,
Klaus Schneider & Klaus Trusheim

Graphics: Birgit Zimmermann

Photos: Fotolia, Industry, Thomas Pletsch,
Birgit Zimmermann. All photos
protected by copyright.

product range subject to change, no liability
accepted for mistakes or printing errors. Right
reserved to make product changes. Copying
of any kind, even of extracts, requires written
permission.





It is extremely important for the emergency services to be able to rely on the products that they are wearing and carrying. This area is therefore particularly important to us.

Our main focus is on immaculate quality, ergonomic design and top performance.



Hatchets/Knives/ Multi-Tools

Fire brigade hatchets	16	Seat belt cutters	25-27
Rescue knives	17-20	Rescue knife	27
Multifunction tools	21-22	Rescue scissors	28
Bags, holsters and		Glass punches	29
Accessories	23-24		



Helmet lamps & Work lamps

UK helmet lamps	30-33	Diver's lamps	42-45
UK accessories	34	Hand lamps	46-47
Helmet holders	35-37	Headlamps	48-50
Work lamps	38-41	Portable floodlights	51-52



Body protection

Forest worker kits	53	Socks and boots	61
Hearing protection	54	Protection suits	62-66
Breathing masks	54	Rain clothing	67
Safety goggles	54	Clothes hanger	68-69
Gloves	55-60		



Ropes/Belts

Slings	70	Fire brigade ropes	71
Fire brigade safety belts	70	Karabiner	71



Belts/Holsters/ Bags

Belt	72	Backpacks	75
Holster	73-75	Fire brigade leather bag	76
Bags	75	Breathing air cylinders	77

**Fire brigade hatchet
DIN 14924-FBD Dönges**

Red-painted head with ground splitter and narrow pike at the other side, with oval tubular steel handle inserted into the head.

Non-slip rubber hand guard with integrated triangular key for bollards, hydrants etc., GS symbol
The integrated bollard key makes this quality hatchet ever more useful to firemen and increases the number of uses considerably.

Integrated post wrench

Sturdy forged and smartly chrome-plated triangular socket spanner insert integrated in end of handle. The hatchet therefore makes it possible to open any posts or bollards in accordance with DIN 3222.



Order no.	Length mm	Weight g
202005	330	1000



exclusive *DÖNGES*



**Fire brigade hatchet, chrome-plated,
DIN 14924-FBD Dönges**

Neatly ground and chrome-plated fire brigade hatchet, suitable as gift or as decorative hatchet, but also for normal use.

Non-slip rubber hand guard with integrated triangular key for bollards, hydrants etc. Of course, this chrome-plated hatchet is fully functional, since it complies with the same quality standards as the standard hatchet.

**New! screw for
Securing handle!**



Order no.	Length mm	Weight g
202006	330	1000

exclusive *DÖNGES*



**Fire brigade hatchet DIN 14924-FB
Dönges (previous standard 06/1992)**

Red-painted head with ground splitter and narrow pike at other side, with oval tubular steel handle inserted into the head, non-slip rubber hand guard.

The hatchet no longer complies with the current DIN 14924, since it does not have the integrated bollard wrench. Otherwise this hatchet also complies with all of the required quality and stability criteria.



**Additional hatchets
and axes can be found
on pages 84-88 and 112**

Order no.	Length mm	Weight g
202010	330	1000

exclusive *DÖNGES*



Protective bag DIN 14924 Dönges

Protective holster for fire brigade hatchet, made from black leather with belt loop, specially adapted to new hatchet with triangle, top quality leather and workmanship.

Features:

- excellent leather quality
- metal-reinforced corners
- optimum fit

Order no.	Weight g
202015	160

exclusive *DÖNGES*

Supplied without hatchet



Glas Master Pocket Rescue Tool PRT

PRT pocket rescue knives have been designed for users who wish to carry a small, lightweight rescue knife but do not wish to lose any functionality.

The large thumb opener and the large release button allow the equipment to be used whilst wearing thick gloves.

The hafts are made from anodised aluminium, blade, internal mechanism and stainless steel belt clip. The materials, the many years of experience of the manufacturer and state-of-the-art manufacturing methods ensure that the rescue knives have consistent, high quality and a long service life.

You will not find a comparable rescue knife on the German market.

Features:

- One-handed operation (also with gloves)
- Stainless, lockable blade
- Super-sharp 1/2 serrated edge
- Stable belt clip
- Safety belt cutter
- Window breaker
- Extremely durable aluminium handle
- Made in Solingen, two-year guarantee
- Open/closed length 122/206 mm

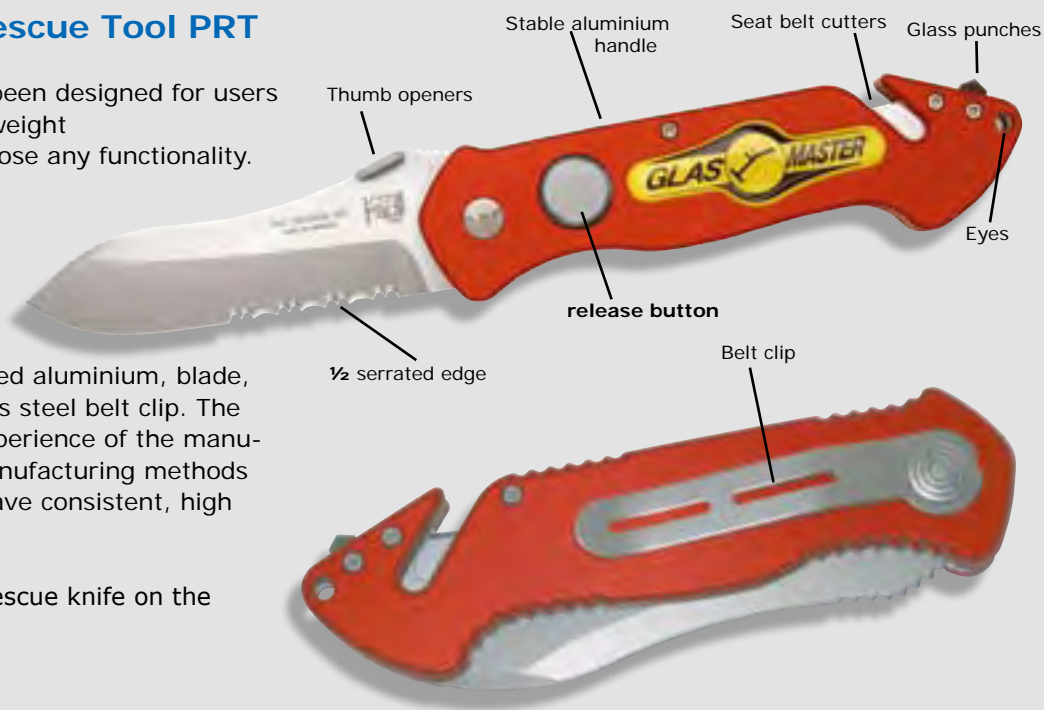

exclusive **DÖNGES**



made in Germany

Laser engraving on blade possible at additional price

Pocket Rescue Tool PRT-I

Order no.	Blade shape	Colour	Weight g
212401	Standard	silver	130

Pocket Rescue Tool PRT-II

Order no.	Blade shape	Colour	Weight g
212402	Hump shape	red	140

Pocket Rescue Tool PRT-III

Order no.	Blade shape	Colour	Weight g
212403	Tanto	black	140

Pocket Rescue Tool PRT-IV

Order no.	Blade shape	Colour	Weight g
212404	Rounded	black	140

Pocket Rescue Tool PRT-XI

Order no.	Blade shape	Colour	Weight g
212431	Hooked blade	red	140



Dönges "Economy" rescue knife

This knife adds a low-cost model to our extensive product range. Contains all of the essential functions.

Features:

- One-handed operation (blade can be conveniently opened and closed using the thumb opener)
- Stainless, lockable blade
- Super-sharp 1/2 serrated edge
- Stable belt clip
- Safety seat belt cutter
- Window breaker
- Extremely durable aluminium handle
- The red rubber handle inlay provides a secure grip



exclusive **DÖNGES**



Suitable holsters and reel-in holsters can be found on page 23



Laser engraving on blade possible at additional price

Order no.	Length closed mm	Length open mm	Weight g
212439	125	210	170

Glas Master Rescue Tool I

exclusive **DÖNGES**



made in Germany

This universal gravity knife has been developed on the basis of the well-tried paratrooper knife. The grip is almost unbreakable and can even withstand being driven over by a car. This knife is the optimum choice due to the integration of all fire brigade-specific requirements.

Features:

- One-handed operation (blade falls out of handle when thumb opener is operated)
- Stainless, lockable and replaceable blade
- Super-sharp 1/2 serrated edge
- Suspension eye
- Marlin spike (for loosening knots etc.)
- Non-slip, extremely durable, acid and temperature resistant plastic handle
- Window breaker
- Capsule lifter
- Made in Solingen, two-year guarantee



Order no.	Length closed mm	Length open mm	Weight g
212410	137	224	200



Dönges RBE rescue knife

The all-new rescue knife. The RBE is impressive because of its top quality materials, excellent workmanship and well thought-out functions.

Winner of "Messer-Magazin" 01/07 test



1

2



Laser engraving on blade possible at additional price

The ergonomically shaped haft made from fibre glass-reinforced plastic also withstands the harshest of treatment. The large thumb opener on the back of the blade can be easily operated from both sides whilst wearing gloves. The blade made from 440-C high-performance steel is rounded in order to minimise the risk of injury during rescue operations. The serrated edge effortlessly cuts through thick rope, and the belt cutter on the back of the blade can even be used whilst the blade is closed.

The knife also has a window breaker at the bottom end which can be easily replaced. The lock of the blade can also be used as a hammering tool.

The belt clip can be moved from one side of the knife to the other with just a few actions as an independent tool. The tool that is required is included in the scope of delivery. This makes the knife also suitable for left-handed persons.

Two versions of the knife are available: for use by the fire brigade and the emergency services with

red handle and a silver blade, and for use by the police and the security services with a black handle and a black blade.

Features:

- Extremely strong haft made from GFK
- Lockable blade made from 440-C high-performance steel
- Super-sharp 1/2 serrated edge
- Stable belt clip
- Safety belt cutter on back of blade
- Replaceable window breaker
- Open/closed length 230/135 mm
- Two versions available

Order no.	Colour	Weight g
1 212436	red	170
2 212437	black	170

Dönges Rescom seat belt knife

This seat belt knife has been completely redesigned and uncompromisingly optimised with regard to the cutting of seat belts and ropes.

This extremely small and handy knife can even be effortlessly opened with one hand wearing gloves. The stainless cap hooked blade (material AUS-8) is suitable for belts and also for climbing and securing ropes with a diameter of up to 10 mm. The special blade shape and the extremely sharp (serrated) edge ensure that cutting is problem-free.

Features:

- Extremely strong haft made from Zytel
- Lockable cap hooked blade made from AUS-8 steel
- Super-sharp 1/2 serrated edge
- Stable belt clip

Order no.	Length closed mm	Length open mm	Weight g
212438	69	112	66



Rescue Tool III

This professional rescue tool has been developed together with firemen and is the optimum addition to personal safety equipment. The heavy-duty version makes it easy to smash vehicle windscreens. With the integrated glass saw, even the windscreen can be removed within a short time.



The holster that is provided has a loop (11 cm wide) for a fire brigade belt and two removable hook-and-loop fasteners for securing to the BA shoulder belt.

Features:

- Stainless blade
- Non-slip fibre glass-reinforced handle
- Special glass saw
- Super-sharp serrated edge
- Wide screwdriver blade or lever cutter
- Window breaker
- Signal strip that illuminates for up to 40 hours
- Nylon holster
- Made in Solingen
- Two-year guarantee

Order no.	Overall length mm	Length of holster mm	Weight g
212416	270	280	385

made in Germany



Multi-Tool Economy, 11 functions

Stable, robust multi-tool made from stainless steel, with black anodised aluminium haft. Specially coated tool surfaces provide easy cutting and a long service life. The multi-tool is supplied in a high-quality belt holster in a gift box.

Functions:

- Pliers with wire cutter
- Standard blade
- Small blade
- Saw
- Slotted screwdriver, small
- Slotted screwdriver, medium
- Slotted screwdriver, large
- Philips screwdriver
- Can opener
- Bottle opener
- File

Order no.	Dimensions mm	Weight g
212905	110 x 50 x 20 mm	200



Gerber Suspension Multi-Tool

The pliers of the Suspension are extremely easy to open and then convenient to use. The reason for this is the integrated spring.

The nine tools on the outside are practical, and include scissors, a saw, a blade, a bottle opener and a screwdriver.

The Multi-Tool has a one-handed opening mechanism. All tools can be locked and then unlocked after use using the slider on the handle. The skeleton handle makes the Suspension even lighter and a technical eye-catcher.

Including stable nylon holster with belt loop.

Functions:

- Pointed pliers
- Wire cutters
- Smooth blade
- Serrated edge blade
- Scissors
- Saw
- Philips screwdriver
- Small/medium sized slotted screwdriver
- Can opener
- Bottle opener
- Suspension eye

Order no.	Closed length mm	Colour	Weight g
212906	102	grey	254

Gerber Flik Multi-Tool

The Flik represents the addition of an extremely handy tool to Gerber's multi-tool product range without compromising functionality.

The Flik is impressive because of its external tools and robustness. The pliers can be conveniently and quickly opened with one hand, as can the saw, the scissors and the knife blade.

Thanks to its compact size, the Flik multi-tool becomes a constant companion that you will want with you at all times.

All of the tools are external, and can be opened independently of the pliers. The Flik has many uses thanks to the wide range of screwdrivers.

The fixing mechanism provides maximum safety when working with the tools.

Including stable nylon holster with belt loop.

Functions:

- Multifunction pliers
- Knife (smooth blade; serrated edge)
- Scissors
- Saw
- Screwdriver (Philips/slotted head)
- Can opener
- Bottle opener

Order no.	Colour	Closed length mm	Weight g
212907	silver	112	248



Gerber Legend MP800 Multi-Tool

The legend, also known as the MP800, is a classic Gerber tool with pointed pliers.

All of the tools that are accommodated in the legs of the pliers are accessible from the outside. Frequently used tools such as the knife and the scissors can be opened with one hand. All tools are locked automatically after opening. To prevent slipping the handles have black Gator-Tex-Grip inlays. The head of the pliers is equipped with a carbide hard metal cutter that can be replaced. Comes with nylon case.

Functions:

- Multifunction pliers
- Pointed pliers
- Replaceable carbide wire cutter with groove for hard wire
- Smooth blade with serrated edge at base (one-handed operation)
- FISKARS scissors
- Replaceable saw blades (2 3/4")
- Philips screwdriver
- Small/medium/large slotted screwdriver
- Bottle opener
- File
- Suspension eye

Order no.	Colour	Closed length mm	Weight g
212908	grey metallic	110	252

Dönges knife holster

Stable knife holster made from nylon fabric with 100 mm wide belt loop for securing to fire brigade belt, or for vertical attachment as shoulder strap of breathing apparatus with optionally available adapters. Suitable for all PRT knives, Rescue Tool I, rescue knife and other appropriately sized knives.

Order no.	Item	Dimensions mm	Weight g
212427	Bag	160 x 45 x 35	20
212428	Breathing apparatus adapter set		10



DÖNGES
exclusive

Dönges reel-in holster

Designed by professionals for professionals: patented, extremely stable nylon sleeve with special reel-in mechanism. You can work with the knife within the usual action radius without losing the knife. A 1.2 mm thick and 1.10 m long steel cable secures the knife in case it falls out of during use. This steel cable automatically runs back into a drum mechanism at the bottom end of the holster using a spring mechanism.

The original Key-Bak reel-in mechanism from the USA is almost indestructible. The holster is secured to the safety belt by a loop with press-studs. A securing kit for the majority of knife models is also provided. Ideally suitable for the Pocket-Rescue-Tool PRT, Eickhorn RT-1, Hanodor RM-1, Hubertus knife, Leatherman®, etc.

Order no.	Length mm	Weight g
212423	170	140



DÖNGES
exclusive

Dönges pocket knife

As your daily companion for operations, leisure time and at work: this Swiss officer's knife made by Wenger has impressive quality and useful functions. This Swiss brand name product has seven functions. The semi-transparent blue haft is also an attractive feature.

Functions:

- Knife blade
- Capsule lifter with Screwdriver
- Corkscrew
- Can opener
- Pricker
- Nail file
- Suspension eye

Order no.	Closed length mm	Weight g
212498	90	60



Printing possible at additional cost

Designer pocket knife with 11 tools

Attractive pocket knife with steel haft and rubberised thumb rest. All parts are stainless.

Functions:

- Knife
- Fish knife
- Philips Screwdriver
- Saw
- Scissors
- Capsule lifter with Screwdriver
- Corkscrew
- Can opener
- Nail file
- Piercer
- Pricker
- Suspension eye

Order no.	Closed length mm	Weight g
212504	90	110



Knife chain

Stainless, strong steel link chain with two karabiners and key ring for securing any knife.

Order no.	Length mm	Weight g
212430	470	20



Spiral cable

Strong, plastic covered spiral cable for attaching a knife, key ring etc. The steel cable inside is extremely sturdy and always returns to its original shape, even after being subjected to considerable strain. Cable will not twist or become overstretched, even after long period. Loop with screw locking device at one end, karabiner hook at the other end.



made in Germany



Variable attachment

Order no.	Colour	Length cm	Weight g
212483	transparent	35/125	40
212484	black	35/125	40

Belt knife

Slightly curved, stainless, super-sharp steel blade 160 mm long, with safety knob at the tip and black plastic handle.

Leather sheath optionally available.



made in Germany

Order no.	Item	Weight g
212480	Knife	125
212482	Leather sheath	25

Cap knife

For providing assistance in the event of accidents, with replaceable, super-sharp blade that cuts at three sides. The special shape ensures that cutting is reliable and effortless, particularly with regard to ropes and cables. The leather sheath is optional.



Order no.	Item	Weight g
212490	Knife	110
212492	Spare blade	40
212494	Leather sheath	30



made in Germany

Sanson portable sharpener

Sharpens all types of knives, scissors and blades quickly and effectively. The extremely hard sharpening inserts are almost as hard as diamond (96 HRC Rockwell), but less susceptible to wear, and can also be turned. This increases the service life considerably. The handle is made from diecast zinc and makes the Sanson almost indestructible. Guarantee: five years. The three provided sharpening inserts are easy to replace.

Order no.	Item	Length mm	Weight g
212485	Sharpener	185	320
212486	Sharpening inserts, 3-piece		90



Dönges seat belt cutter

Extremely robust seat belt cutter with reinforced neon yellow ABS handle and strong blade protected in the knife body.

Order no.	Item	Length mm	Weight g
212435	Belt cutters	175	80
212434	Spare blade		5

With replaceable precision blades from Solingen!



exclusive **DÖNGES**

made in Germany

Ruck-Zuck seat belt cutter

With fibre glass reinforced, red handle made from polyamide and blade protected in the body of the knife. GS tested.

Order no.	Length mm	Weight g
212488	155	80



Mini-Salvex seat belt cutter

Seta belt cutter and rescue hammer made from fibre glass reinforced, red polyamide with ceramic journal. Smashes any side window without problems, and effortlessly cuts seat belts and clothing. With Hook & Loop strip for securing in the vehicle. GS tested.

Order no.	Length mm	Weight g
212489	160	100

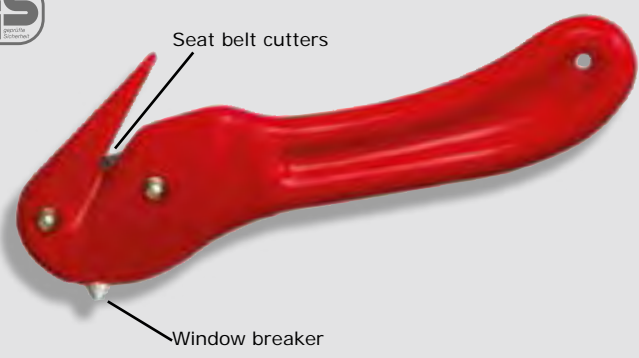

SOS Cutter

Credit card sized seat belt cutter made from polystyrene with encapsulated blade. Can be kept anywhere, sharp blade effortlessly cuts through seat belts and clothing. Blade is protected and prevents injuries.

Order no.	Length mm	Weight g
212487	100	40



RN-2 rescue knife

Patented rescue knife from the USA for fire brigade, police and rescue services. Extremely sturdy metal structure.

Two replaceable blades are securely anchored in the "V". The rounded edges prevent injuries to the rescue victim. The heavy head can even smash thick panes of glass. The shape of the handle prevents the device from falling out of your hand.

The special DZUS connection makes it possible to open aircraft and vehicle doors.



Order no.	Item	Length mm	Weight g
212477	Rescue knives	240	460
214479	Spare blade (pair)		5



Universal tool Res-q-me

This little emergency helper for carrying on a key ring is the ideal tool for car accidents and emergencies for cutting safety belts and smashing side and rear car windows. The seat belt cutter cuts through the seat belt without problems in the event of an emergency, and is also useful for cutting through clothing.

The integrated window smasher can be used to open any side or rear window in a vehicle with little effort. The Res-q-me fits on any key ring and can ideally be left in various locations in the vehicle.

Features:

- Belt knife
- Spring centre punch
- Key ring and blade guard

Order no.	Colour	Length mm	Weight g
212496	black	75	20
212495	fluorescent orange	75	20

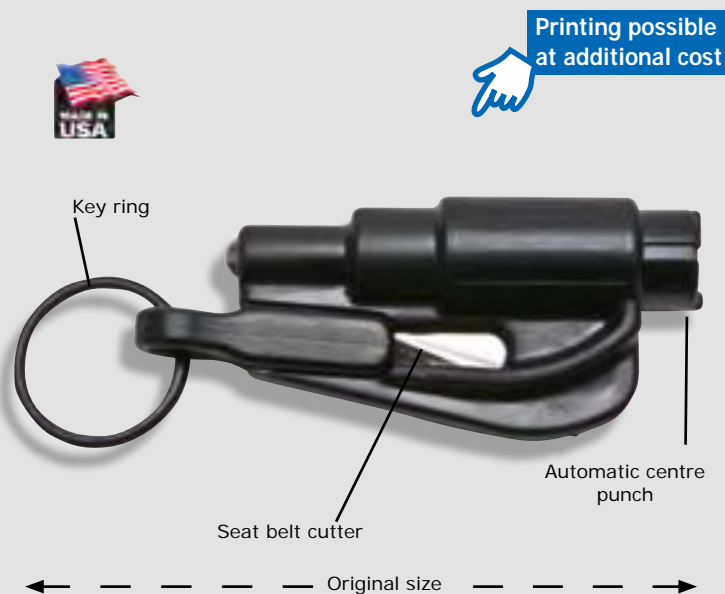



Cologne rescue scissors

This useful kit was developed on the basis of an idea from the Cologne professional fire brigade. The sturdy holster made from nylon fabric with reflective strips contains all-purpose scissors for quick and reliable cutting of lines and ropes with one hand.

The holster also contains one wooden wedge, for keeping access and exit doors open.

The scissors can be secured to the holster using an optionally available securing cord.

Two versions of the kit are available: with "Dönges" universal scissors and original Finny scissors, made in Solingen.

Order no.	Item	Length mm	Weight g
1 212506	Dönges version	220	300
2 212508	Finny version	220	320
3 212510	Securing cord	80	5

made
in
Germany



Special glass punch

Hardened, automatic special spring centre punch for opening side or rear windows. One-handed operation: just position and push!

The device can be kept in the handle of the original Glas-Master or used as an independent tool. Made from brass with hardened steel tip.

Order no.	Length mm	Weight g
211314	130	60



Spring glass centre punch

Simple but extremely effective tool for destroying the side and rear windows of accident vehicles. The centre punch is placed on the window and the spring is then tensioned. As soon as the spring is released, the end of the centre punch strikes the tip - and the window shatters.

Order no.	Length mm	Weight g
211315	120	60



The new generation of the UK 4AA Helmet lamps and working lamps

The best-selling, explosion-proof helmet lamp in the fire brigade and rescue service has been completely renewed. The successor models supplement the well-tried and reliable product range from the USA and are impressive because of their technically unique high-end designs for the most demanding of applications. Absolutely outstanding quality, tremendous luminance, light weight and extremely good price/performance ratio are the characteristics of these lamps, which were developed by experts in California with **more than 35 years of experience**. There are many pocket and helmet lamps, but UK products remain unique. Developed and manufactured by enthusiasts for enthusiasts.

The most important and most revolutionary new feature is the Compound Path Optics (CPO) technology that is now installed in top products. This totally new and patented, extremely flat lens system is 85 % more efficient and has just 1/5 of the depth of traditional reflectors. The so-called Thermal Recovery System that has been registered for patent recycles LED heat to increase the capacity of the battery. The UK 4AA helmet and work lamps are therefore still the best lamps for your requirements. The UK 4AA is also recommended as a helmet lamp for hands-free use by leading helmet manufacturers as an official accessory, and is not one of the most successful lamps for fire brigades, industry, trade, police and military without reason.

The advantages of the new lamp generation at a glance:

Compound Path Optics (CPO):

Extremely efficient reflector technology in a confined space. The light of the extremely bright high-performance LED, which exits from the front, is first reflected back by a mirrored lens and then exits as a concentrated beam of light after being bundled by the reflector. Unwanted diffused light is therefore reduced to an absolute minimum. The spot remains clearly defined, but large enough to provide visibility in any situation.



Thermal Recovery System (TRS):

Modern high-performance LED's lose power as they become hotter. On the other hand, the performance of the batteries deteriorates as the temperature drops. UK has now transformed these two characteristics into a positive effect with the Heat Recovery System. The system ensures that the heat that is given off by the LED is led to the batteries. The result: the light output of the LED's remains at the maximum level even for long periods, and the duration of use with batteries is increased by up to 10%!

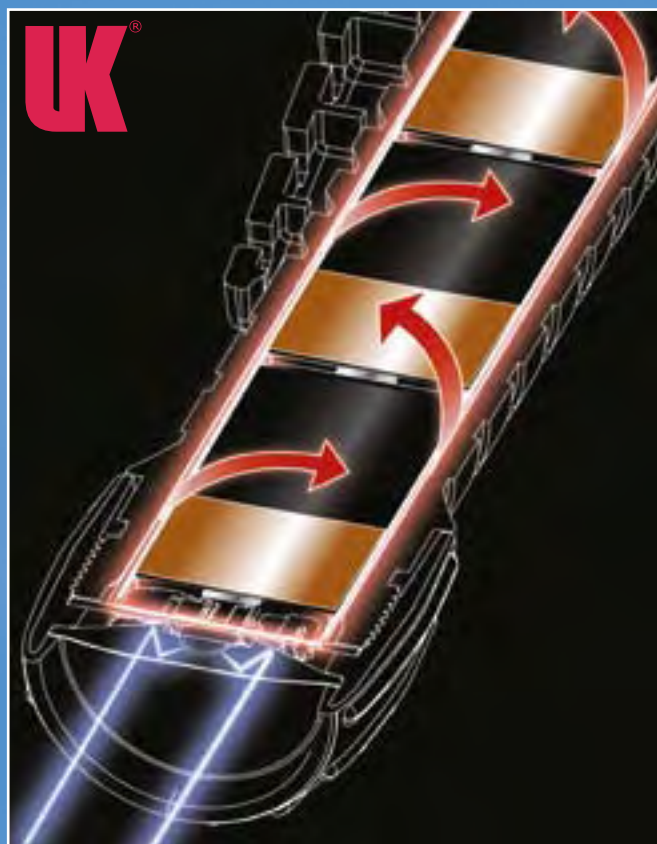

Internally-developed electronics

UK is the only manufacturer of LED lamps that develops its own electronic components and circuitry, and only uses them in its own lamps. UK lamps therefore achieve efficiency of up to 90%. By comparison: other makes that use ready-made, chip-based circuitry achieve efficiency of 60 to 85%.

There are many lamps, but only one original: UK 4AA – the first choice for all operations

On the following pages you will find an overview of all available models and versions in the UK 4AA model series. All of these models are compatible with the original helmet designs in our product range, and are all supplied with brand name alkaline batteries. The helmet designs for all popular fire brigade and work safety helmets can be found on pages 35-37.

By the way:

all UK 4AA lamps can be individually overprinted if required. Talk to us! We would be pleased to design a customised blister card for you!



UK 4AA CPO TS/ES

The new high-end model from the UK 4AA model series. This lamp has all of the newly-developed technical features such as CPO (Compound Path Optics) and TRS (Thermal Recovery System). This is the most powerful lamp in the UK 4AA product range, with luminous power of 90 lumen. The lamp is equipped with a rubberised rear switch that is easy to operate with your thumb. In combination with its extremely bright light, this also makes the lamp an interesting alternative for security forces. Of course, this lamp also has the option of switching on and off by rotating the top of the lamp.

Technical data:

- Output: 2 Watts
- Luminance: 90 lumen
- Operating: 8-10 hrs.
- Dimensions: 157 x 40 x 34 mm

Explosion

protection class: II 2G EX e ib IIC T4
II 2D Ex ibD 21 T 98° C

Scope of delivery:

UK 4AA CPO TS/ES on blister card, with 4 AA batteries (Mignon)

Order no.	Item	Colour	Weight g
219516	TS, rear switch	black with reflective stripes	159
1 219511	TS, rear switch	black	159
219517	ES, front switch	black with reflective stripes	159
219521	ES, front switch	black	159



Individual lettering on request.



New, brighter CPO lenses



Practical rear switch

UK 4 AA eLED Zoom S/T

The new improved version of the well-tried UK 4 AA eLED Zoom. Additional light efficiency by means of a much-improved high-performance LED and the improved explosion protection class emphasise this product's claim to be the standard in its performance class. The UK 4 AA eLED Zoom can now be ordered with either the well-tried front switch or the new rear switch (model T). This makes it an excellent lamp for security forces. Of course, this lamp also has the option of switching on and off by rotating the top of the lamp. With individual lettering on request.

Technical data:

Output: 3 Watts
 Luminance: 80 lumen
 Operating: 10.5 hrs.
 Dimensions: 172 x 40 x 37 mm

Explosion

protection class: II 2G EX e ib IIC T4
 II 2D Ex ibD 21 T 98°C

Scope of delivery:

UK 4 AA eLED Zoom S/T on blister card with 4 AA batteries (Mignon)

Order no.	Item	Colour	Weight g
1 222002	eLED Zoom S, front switch	neon yellow	159
222006	eLED Zoom S, front switch	black	159
222008	eLED Zoom T, rear switch	neon yellow	159
222012	eLED Zoom T, rear switch	black	159
222014	Spare reflector		25

Zoom Feature

Our 4AA eLED Zoom is the only light of its kind with a true zoom system, allowing you to focus the even beam from wide to narrow by twisting the bezel. Other lights create a hole in the center of the beam when the zoom is used. With greater beam control, you get just the right light for your job.

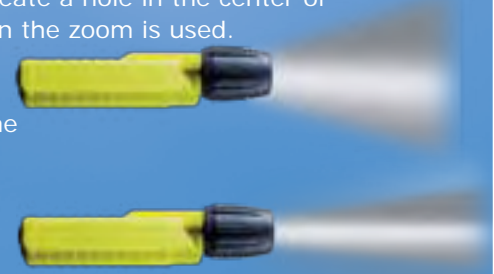

1
 Individual lettering on request.

New, improved explosion protection! Complies with requirements of pre-standard DIN 14649



Version T with practical rear switch



UK 4 AA EN Xenon

Basic configuration. Low-cost, reliable xenon technology for good light output and rotating head switch for switching on and off. Pure functionality. Nothing else!

Technical data:

Output: 2.1 Watts
 Luminance: 38 lumen
 Operating: 4-5 hrs.
 Dimensions: 157 x 40 x 34 mm
 Explosion protection class: II 2G EX e ib IIC T4
 II 2D Ex ibD 21 T 98° C

Scope of delivery:

UK 4AA-EN on blister card with 4 AA batteries (Mignon)

Order no.	Item	Colour	Weight g
222036	EN Xenon	neon-yellow	148
222038	EN Xenon	black	148
222042	Spare reflector		
	UK4AA ES/EN/ET		10



Individual lettering on request.

New, improved explosion protection! Complies with requirements of pre-standard DIN 14649



UK 4 AA ES/ET Xenon

The best seller. The most frequently sold and widely used helmet lamp. Low-cost, reliable xenon technology for extremely good light efficiency. This light now also has improved explosion protection and an optional rear switch (ET model). Of course, both the rear switch and the front switch version can also be switched on and off using the rotating head. With individual lettering on request.

Technical data:

Output: 2.1 Watts
 Luminance: 38 lumen
 Operating: 4-5 hrs.
 Dimensions: 157 x 40 x 34 mm

Explosion

protection class: II 2G EX e ib IIC T4
 II 2D Ex ibD 21 T 98°C

Scope of delivery:

UK 4AA-ES/ET on blister card with 4 AA batteries (Mignon)

Individual lettering on request.



Available from stock with "FIRE BRIGADE" overprint with individual lettering on request.

Order no.	Item	Colour	Weight g
222020	ES, front switch	neon yellow	148
222024	ES, front switch	black	148
1 222026	ET, rear switch	neon yellow	148
222032	ET, rear switch	black	148
222042	Spare reflector		
	UK4AA ES/EN/ET		10



1



Version ET with practical rear switch

New, improved explosion protection! Complies with requirements of prestandard DIN 14649



UK 4 AA R eLED

The well-trying UK 4 AA eLED as rechargeable lamp. The NiMH battery pack of the lamp can be quickly recharged using the supplied charging station. Either using the power supply or in the vehicle using the optionally available 12 V adapter cable. Ideal solution for anyone who does not require explosion protection and does not wish to use batteries.

Features:

- Rechargeable up to 1000 times
- Recharging time of just 1.5 hrs.
- 12V commercial vehicle charging cable optionally available
- All existing accessories such as helmet holders, belt pockets etc. can continue to be used

ATTENTION:

the lamp does not have European ATEX explosion protection certification, but American UL certification.

Technical data:

Output: 4 Watts
 Luminance: 70 lumen
 Operating: 4-5 hrs.
 Dimensions: 172 x 40 x 37 mm

Scope of delivery:

UK 4AA R, 230 V quick charging device, four NiMH batteries (not replaceable)

Order no.	Item	Colour	Weight g
219550	R eLED	neon yellow	170
219555	R eLED	black	170
219545	R eLED w. angular head	neon yellow	170
219540	R eLED w. angular head	black	170
219433	12V Vehicle charging plug (accessory for charging station)		320

Printing possible at additional cost





Usage example, supplied without lamp and angular head

UK 4 AA Pocket Clip

Small but useful accessory for all UK 4 AA models. Simply slide over the lamp unit and the lamp can easily and quickly be secured to a belt, BA belt or shoulder flap.

Order no.	Colour	Weight g
219200	black	10



UK 4 AA Unilite Head

The reflector of the lamp can be angled by 90° with the aid of this angular head, which can be easily screwed between the UK 4 AA housing and the lamp head. The lamp can therefore be carried in a breast pocket or on a BA belt and illuminates towards the front.

Suitable for all UK 4 AA models. The explosion protected lamps in the UK 4 AA series are also certified with a Unilite head.

Order no.	Colour	Weight g
219195	black	30



Usage example, supplied without lamp and pocket clip

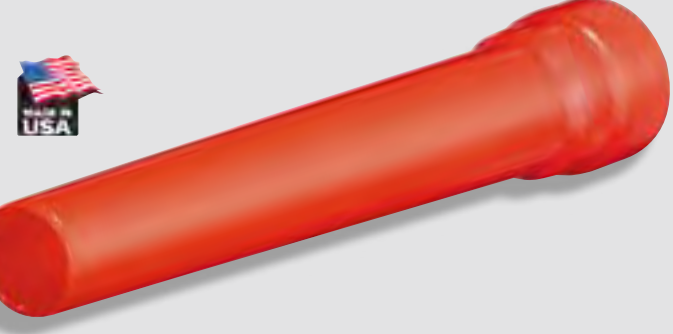

Warning wand for UK 4 AA

Universal warning wand for all UK 4 AA models. For warning traffic, directing vehicles or marking accident locations.

Order no.	Colour	Weight g
219075	red	30

Belt bag for UK 4 AA

Sturdy belt bag made from nylon for all UK 4 AA models. With large loop on rear, also suitable for fire brigade safety belts.

Order no.	Colour	Weight g
219130	black	50



Usage example
Supplied without lamp



Universal helmet clip

4-piece plastic holder, suitable for the majority of helmets, many adjusting facilities, in blister pack, made in USA.



Order no.
219125

Weight g
60



Helmet clip for DIN 14940 helmet

The new, considerably improved version of the widely used standard helmet holder for DIN helmets. With new plastic holder that holds the lamp extremely securely. A rubber ring between the metal bracket and the plastic holder ensures that the angle of the lamp is easy to adjust and does not change, even if rapid movements are made with the head. The edge of the helmet is protected from damage by a sturdy rubber pad. Low-cost but top quality holder, also suitable for many other helmet types.

exclusive **DÖNGES**

Individual overprint remains visible 



Order no.
219110

Weight g
75

Helmet clip for DIN 14940 helmet

Stainless steel, adjustable, extremely sturdy metal/plastic holder. Stainless steel provides extremely good stability and a long service life. The lamp holder is easy to twist for adjusting purposes. Extremely high quality - Made in Switzerland, packed in a plastic bag.



Order no.
219170

Weight g
80

Helmet clip for Schubert F200/F210/F220

Made from stainless steel, the material stands for high quality and a long service life. For inserting into the provided receptacle attached to the helmet. Extremely sturdy and robust. The lamp holder is easy to twist for adjusting purposes. Made in Switzerland, packed in a plastic bag.



Order no.
219175

Weight g
70

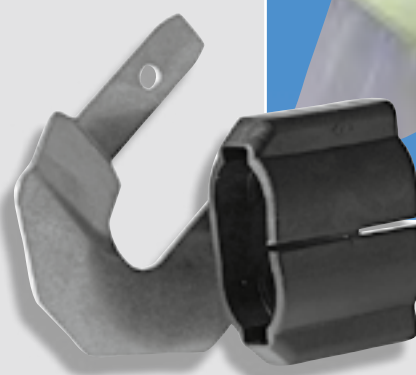

UK helmet clips

Personal equipment

Helmet clip for Schubertsh F100/F110/F120/F200/F210/F220



Helmet holder for screwing into thread in helmet. A circlip and a rubber ring allow the height of the lamp to be adjusted by simply twisting. The lamp remains in position, even if rapid movements are made with the head.

Order no. **219180** Weight g 35



Helmet clip for Rosenbauer Heros



extremely sturdy helmet holder made from stainless steel or plastic, specially for Rosenbauer Heros helmets. Secured to lower edge of helmet. The stainless steel bracket also lies against the helmet shell and therefore provides even more stability for the lamp. The height of the lamp is adjusted by simply twisting.

Order no. **219185** Weight g 65



Helmet clip for Gallet F1SA



Extremely sturdy helmet holder made from stainless steel or plastic, specially for Gallet A2 helmets. Secured to existing screw. The lamp is ideally positioned at eye level, meaning that the beam of light is always pointing in the right direction. The height of the lamp is adjusted by simply twisting.

Order no. **219190** Weight g 60



Helmet clip for Gallet F1SA

Plastic helmet holder for securing to edge of helmet on left side. The lamp can be simply removed from or re-attached to the mounting rail at the edge of the helmet using the plastic holder. The height of the lamp is adjusted by simply twisting.

Order no. **219210** Weight g 60



Helmet clip for Gallet F1S/F1E

Plastic helmet holder for securing to bottom right edge of helmet. The lamp can simply be removed from the mounting rail on the edge of the helmet together with the plastic holder inserted again. The height of the lamp is adjusted by simply twisting.

Order no. **219205** Weight g 60



Helmet clip for Gallet F1SF

Without bottom part, made from plastic, unusual lamp holder for inserting into the mounting rail in the helmet. Holds the lamp securely, even if rapid movements are made with the head. Height can be adjusted by twisting the holder.

Order no. **219111** Weight g 35



Helmet clip for Gallet F2X-TREM

Special holder for securing to the provided holder on the Gallet F2X-TREM. Robust combination of stainless steel and plastic, height adjustable by simply twisting the lamp holder.

Order no. **219211** Weight g 60

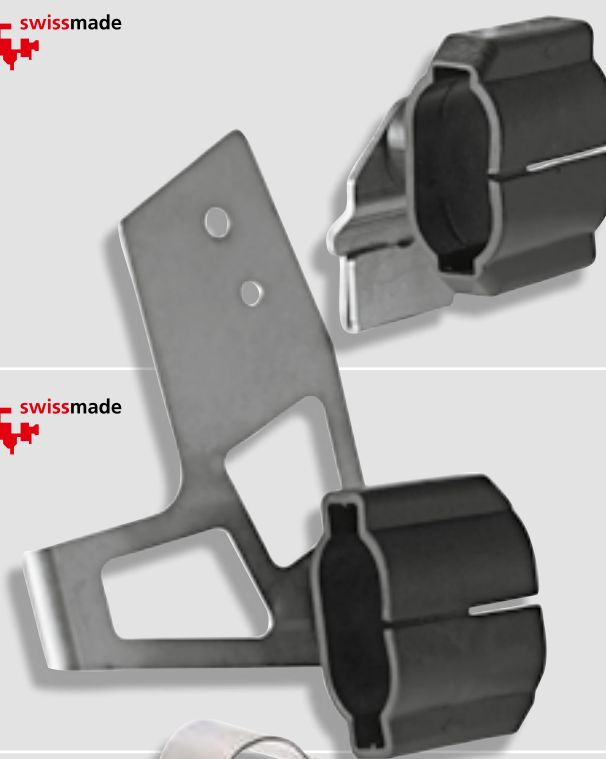

Helmet clip for Dräger HPS 6100

Special holder for securing to the provided holder on the Dräger HPS 6100. Robust combination of stainless steel and plastic, height adjustable by simply twisting the lamp holder.

Order no. **219183** Weight g 70



Helmet clip for helmets with vertical edge

Helmet holder for the helmets that are particularly widespread in North America with a horizontal helmet edge. Also suitable for work safety helmets with such an edge. All stainless steel. Height adjusted using large, easy to operate plastic adjusting screw.

Order no. **219475** Weight g 65



Super Q eLED work light Rechargeable Lithium Ion

The new high-end model among the work lamps in the UK product range. This lamp has all of the newly-developed technical features such as CPO (Compound Path Optics) and TRS (Thermal Recovery System) and is operated using a rechargeable lithium ion battery. This is the most powerful lamp in its class and size with luminous power of 100 lumen. Tremendous light output in an extremely compact design. Small light and still powerful. The companion for anyone who requires plenty of light without having to carry a large, heavy lamp around. The lamp is switched on and off by rotating the head of the lamp. The lamp is reliably sealed by a double O-ring. It therefore remains waterproof up to depth of 150 m and is therefore extremely suitable for working underwater!

The electronics provide consistent brightness, even when the batteries are becoming run down. The brightness only reduces just before the batteries are empty. The lamp can then optionally continue to be operated using two CR123A lithium batteries whilst the rechargeable battery is being recharged. Or you can use another rechargeable battery, ensuring that an adequate amount of light is always available.

The belt clip that is integrated in the housing allows the lamp to be quickly attached to a belt or shoulder flap. The lamp is supplied in a box together with a hand strap, a LiIon rechargeable battery and a mains charger.



Features:

- 100% waterproof and dust-tight up to 150 m
- Extremely bright eLED in pre-focussed quality reflector
- Robust ABS housing
- Rotating head switch, rubberised
- Non-conductive
- Corrosion resistant

Technical data:

Rechargeable battery:	Lithium Ion, 3.7 V 2500 mAh
Batteries:	2 x CR123A lithium
Output:	1.8 Watts
Luminance:	100 lumen with rechargeable battery; 60 lumen with batteries
Operating:	4-5 hrs.
Charging time:	4 hrs.
Dimensions:	117 x 36 x 36 mm

Scope of delivery:

Lamp, hand strap, rechargeable battery and charger in a uk-case

Order no.	Colour	Weight g
219320	neon yellow	104

Work light UK 3C TS eLED ATEX

The considerably improved successor model to the well-tried UK 300 work lamp. Now with revolutionary CPO technology (Compound Path System) with excellent luminance and Thermal Recovery System (TRS) for optimum energy utilisation. The rear switch, which can be conveniently operated whilst wearing work gloves or fire brigade gloves, is also new. The switch is protected from unintentional operation, e.g. if the lamp is dropped.

The UK 3C TS eLED is equipped for any type of use. The almost unbreakable plastic housing has a sprung and non-slip belt and jacket clip for quick and secure attachment to work clothing. A steel karabiner ring and a hand strap with fastener are also provided. The ideal explosion-proof hand lamp for equipping emergency vehicles such as fire engines, THW vehicles, rescue service vehicles, police vehicles and other emergency services. The lamp was in the process of being certified in accordance with DIN V 14649 at the time of printing.

Features:

- Rubberised pressure switch
- Waterproof up to 3 m, and dust-tight
- Robust ABS housing
- Extremely bright LED with CPO
- Pressure compensation valve
- Non-conductive
- Corrosion resistant
- EEx protection: certification not yet available at time of printing. Please request this orgo to the home page: www.uk-lights.com

Technical data:

Alkaline batteries: 3 x C
 Output: 2 Watts
 Luminance: 98 lumen
 Operating: 30 hrs.
 Dimensions: 191 x 54 x 49 mm

Scope of delivery:

Lamp with batteries, in box

Order no.	Item	Colour	Weight g
219536	3C TS eLED ATEX	black with reflective stripes	470
1 219531	3C TS eLED ATEX	black	470
241010	Battery C/Baby/LR14		67



Printing possible at additional cost



1



Torch UK 2AAA Penlight ATEX

Small, handy pen torch. Ideal for maintenance and inspection work wherever explosion protection is required. This small and lightweight torch can be carried in you pocket like a ballpoint pen using the clip attached to the housing, and is therefore ready for use at all times.

The lamp is available with a xenon or LED bulb. The xenon technology provides excellent luminance, and the LED version will provide light for an extremely long time with one battery charge.

Both lamps are available with a rotating head switch or a rear switch. The rear switch ensures that the lamp can also be operated one-handed.

Individual printing available from quantity of 50.

UK 2AAA Penlight Xenon

Features:

- 100% waterproof and dust-tight
- Extremely bright xenon bulb in pre-focussed quality reflector
- Rear switch or rotary head switch
- Complies with CENELEC (CE) requirements
- EEx-tested (Ex) in accordance with the latest European (ATEX) standards
- Zone 1: 3806 II 2G Ex ib e IIC T5
- Zone 2: 3807 II 3G EEx nA II T5

Technical data:

Alkaline batteries: 2 x AAA
 Output: 1.21 Watts
 Luminance: 12 lumen
 Operating: 1.5-2 hrs.
 Dimensions: 120 x 17 x 15 mm

Scope of delivery:

Lamp with batteries, on blister

Order no.	Item	Colour	Weight g
1 219070	With rotary head switch	neon yellow	42
219065	With rotary head switch	black	42
2 219080	With rear switch	neon yellow	42
219085	With rear switch	black	42
219020	Spare reflector		5
219005	Optical fibre attachment		20
241002	Battery AAA/Micro/LR03		15



UK 2AAA Penlight eLED

Features:

- 100% waterproof and dust-tight
- Extremely bright or white eLED in pre-focussed quality reflector
- Rear switch
- complies with CENELEC (CE) requirements
- EEx protection: certification not yet available at time of printing.

Technical data:

Alkaline batteries: 2 x AAA
 Output: 0.1 Watts
 Luminance: 4 lumen
 Operating: 14-15 hrs.
 Dimensions: 120 x 17 x 15 mm

Scope of delivery:

Lamp with batteries, on blister

Order no.	Item	Colour	Weight g
219090	With rear switch	neon yellow	42
219095	With rear switch	black	42
219005	Optical fibre attachment		20
241002	Battery AAA/Micro/LR03		15



Torch UK Mini Pocket Light

Extremely small and handy torch for keeping in your trouser pocket or on a key ring. Ideal for maintenance and inspection work, even if explosion protection is required. This small and lightweight torch can be attached to the peak of your cap, for example, using the provided clips, and will illuminate your working area without you having to use your hands.

The lamp is available with a xenon or LED bulb. The xenon technology provides excellent luminance and is ATEX certified, and the LED version will provide light for an extremely long time with one battery charge.

Both lamps can be switched on and off using the rotary head switch.

Features:

- 100% waterproof and dust-tight
- Extremely bright xenon bulb in pre-focussed quality reflector
- Rotary head switch
- Complies with CENELEC (CE) requirements
- EEx-tested (Ex) in accordance with the latest European (ATEX) standards
- Zone 1: 3806 II 2G Ex ib e IIC T5
- Zone 2: 3807 II 3G EEx nA II T5

UK 2AAA Pocket Light Xenon

Technical data:

Alkaline batteries: 2 x AAA
 Output: 1.21 Watts
 Luminance: 12 lumen
 Operating: 1.5-2 hrs.
 Dimensions: 75 x 26 x 15 mm

Scope of delivery:

Lamp with batteries, key ring, belt clip on blister

Order no.	Item	Colour	Weight g
219045	Xenon pocket light	neon yellow	37
219040	Pocket Light Xenon	black	37
219020	Spare reflector		5
219005	Optical fibre attachment		20
241002	Battery AAA/Micro/LR03		15



UK 2AAA Pocket Light eLED

ATTENTION:

this torch does not have European ATEX explosion protection certification, and is therefore not approved for use in potentially explosive zones.

Technical data:

Alkaline batteries: 2 x AAA
 Output: 0.1 Watts
 Luminance: 4 lumen
 Operating: 14-15 hrs.
 Dimensions: 75 x 26 x 15 mm

Scope of delivery:

Lamp with batteries, key ring, belt clip on blister

Order no.	Item	Colour	Weight g
219472	Pocket Light e LED	neon yellow	37
219474	Pocket Light e LED	black	37
219005	Optical fibre attachment		20
241002	Battery AAA/Micro/LR03		15



UK Mini Q40 diver's lamp

This handy high-performance diver's lamp shows its true quality under water. The compact design and optional mask strap allow this lamp to be secured directly to the diving mask for handsfree use. The ABS lamp housing can be securely held in the hand using gloves and can be easily and reliably switched on and off using the rubberised lamp head. The compact design and extremely bright light, the xenon light source and the high-performance eLED make this lamp the ideal companion (backup lamp) underwater.

Mini Q40 Xenon

Features:

- 100% waterproof and dust-tight up to 150 m
- Extremely bright xenon bulb in pre-focussed quality reflector
- Robust ABS housing
- Rotary head switch, rubberised
- Non-conductive
- Corrosion resistant
- Complies with CENELEC (CE) requirements

Technical data:

Alkaline batteries: 4 x AA
 Output: 2.1 Watts
 Luminance: 50 lumen
 Operating: 5-6 hrs.
 Dimensions: 157 x 40 x 27 mm

Scope of delivery:

Lamp with mask strap and batteries, on blister

Order no.	Item	Colour	Weight g
1 219360	Q40 Xenon	neon yellow	153
219359	Q40 Xenon	blue	153
219357	Q40 Xenon	neon green	153
219355	Q40 Xenon	black	153
2 219107	Lamp holder		
	for diving goggles	transparent blue	20
219115	Spare reflector for Mini Q40		10
219150	Wrist strap for all diver's lamps		40
241006	Battery AA/Mignon/LR06		20

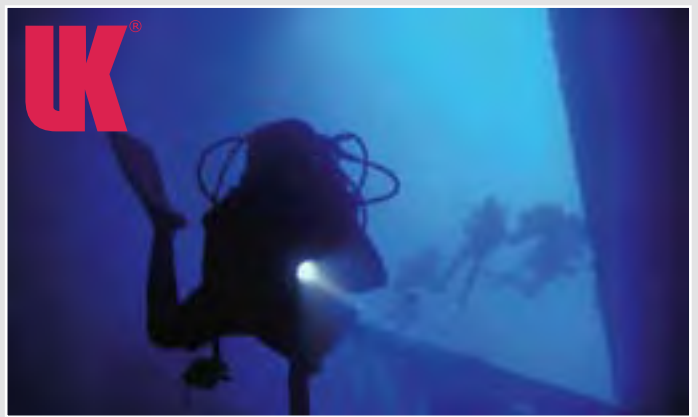

Mini Q40 eLED

Features:

- 100% waterproof and dust-tight up to 150 m
- Extremely bright eLED in pre-focussed quality reflector
- Robust ABS housing
- Rotary head switch, rubberised
- Non-conductive
- Corrosion resistant
- Complies with CENELEC (CE) requirements

Technical data:

Alkaline batteries: 4 x AA
 Output: 2 Watts
 Luminance: 67 lumen
 Operating: 4-5 hrs.
 Dimensions: 157 x 40 x 27 mm

Scope of delivery:

Lamp with mask strap and batteries, on blister

Order no.	Item	Colour	Weight g
3 219356	Q40 eLED	neon yellow	176
219358	Q40 eLED	blue	176
219363	Q40 eLED	black	176
219107	Lamp holder		
	for diving goggles	transparent blue	20
219101	Spare reflector for Mini Q40 eLED Plus		15
219150	Wrist strap for all diver's lamps		40
241006	Battery AA/Mignon/LR06		20



Working/diver's lamp UK SL 4

The UK SL 4 is not just in its element underwater. The handy high-performance lamp shows its qualities both underwater and in use as an inspection and work lamp. The precisely manufactured reflector of the xenon version provides a bright, concentrated beam of light with which distant objects can be made out. The version with high-performance eLED also provides good light output and an extremely long lighting time with one battery charge. The rubberised lamp head reduces dazzling problems and protects the lamp. The rocker switch beneath the lamp head is extremely easy to operate wearing gloves.



SL 4 Xenon

Features:

- 100% waterproof and dust-tight up to 150 m
- Extremely bright xenon bulb in pre-focussed quality reflector
- Robust ABS housing
- Rocker switch for one-handed operation
- Non-conductive
- Corrosion resistant
- Complies with CENELEC (CE) requirements

Technical data:

Alkaline batteries: 4 x C/LR14/Baby
 Output: 5.5 Watts
 Luminance: 113 lumen
 Operating: 4 - 5 hrs.
 Dimensions: 158 x 63 x 40 mm

Scope of delivery:

Lamp with wrist strap and batteries, in box

SL 4 eLED

Features:

- 100% waterproof and dust-tight up to 150 m
- Extremely bright eLED in pre-focussed quality reflector
- Robust ABS housing
- Rocker switch for one-handed operation
- Non-conductive
- Corrosion resistant
- Complies with CENELEC (CE) requirements

Technical data:

Alkaline batteries: 4 x C/LR14/Baby
 Output: 3 - 5 Watt
 Luminance: 33 - 38 Lumen
 Operating: 10 - 12 hrs.
 Dimensions: 158 x 63 x 40 mm

Scope of delivery:

Lamp with wrist strap and batteries, in box

Order no.	Item	Colour	Weight g
219300	SL 4 Xenon	neon yellow	425
219301	SL 4 Xenon	blue	425
219295	SL 4 Xenon	black	425
219270	Spare reflector for SL4 (5.5 Watts)		20
219204	O-ring for UK 300/SL4/SL6		5
219150	Wrist strap for all diver's lamps		40
241010	Battery C/Baby/LR14		67

Order no.	Item	Colour	Weight g
219146	SL 4 eLED	neon yellow	430
219140	SL 4 eLED	blue	430
219144	SL 4 eLED	black	430
219148	Spare reflector for SL4 eLED		20
219204	O-ring for UK 300/SL4/SL6		5
219150	Wrist strap for all diver's lamps		40
241010	Battery C/Baby/LR14		67





Working/diver's light UK SL 6 Xenon

The big brother of the UK SL 4. Because it uses six batteries, the lamp provides significantly more light for the same duration. This handy high-performance lamp reveals its quality both under water and during operations as an inspection and work lamp. The precisely manufactured reflector of the xenon version provides a bright, concentrated beam of light with which distant objects can also be made out. The rubberised lamp head reduces dazzling problems and protects the lamp. The toggle switch beneath the lamp head can be operated extremely easily wearing gloves.

Features:

- 100% waterproof and dust-tight up to 150 m
- Extremely bright xenon bulb in pre-focussed quality reflector
- Robust ABS housing
- Rocker switch for one-handed operation
- Non-conductive
- Corrosion resistant
- Complies with CENELEC (CE) requirements

Technical data:

Alkaline batteries: 6 x C/LR14/Baby
 Output: 8 Watts
 Luminance: 201 lumen
 Operating: 4 - 5 hrs.
 Dimensions: 206 x 63 x 40 mm

Scope of delivery:

Lamp with wrist strap and batteries, in box



1

Order no.	Item	Colour	Weight g
1 219335	SL 6 Xenon	neon yellow	610
219336	SL 6 Xenon	blue	610
2 219330	SL 6 Xenon	black	610
219305	Spare reflector for SL6 (8 Watts)		20
219204	O-ring for UK 300/SL4/SL6		5
219150	Wrist strap for all diver's lamps		40
241010	Battery C/Baby/LR14		67



2

Suitable batteries
on page 192-193



Light Cannon 100 diver's light

Compact, ultimate high-performance portable floodlight with the latest HID burner technology. This portable floodlight has extremely good luminance, which is generated by a high-pressure gas discharge bulb and is several times brighter than halogen or xenon bulbs. Nevertheless, the lighting duration of three to four hours with one set of batteries is more than adequate. The range and the luminance are tremendous. The wide beam and powerful spotlight make this lamp suitable for professional search and rescue operations, signalling and orientation tasks in the field and for diving to depths of up to 150 m. Optionally available with lantern or pistol handle.

Features:

- 100% waterproof and dust-tight
- Super-white HID bulb (high-pressure gas discharge bulb)
- Robust ABS TPE polycarbonate housing
- Unbreakable on/off switch with transport protection
- Thermostat shut-off in the event of overheating, fuse-protected
- Non-conductive, corrosionresistant
- Complies with CENELEC (CE) requirements

Technical data:

Alkaline batteries: 8 x C/LR14/Baby
 Output: 12.5 Watts
 Luminance: 450 lumen
 Operating: 3 - 4 hrs.
 Dimensions: 205 x 63 x 72 mm

Scope of delivery:

Lamp with batteries, hand strap and handle in box



Order no.	Item	Colour	Weight g
219386	Cannon 100 lantern handle	neon yellow	610
219385	Cannon 100 lantern handle	black	610
219381	Cannon 100 pistol handle	neon yellow	610
219380	Cannon 100 pistol handle	black	610
219365	Spare reflector for Light Cannon (12.5 Watts)		20
219599	O-Ring for Light Cannon		5
219150	Wrist strap for all diver's lamps		40
241010	Battery C/Baby/LR14		67

Responder RA handlamp

The design of this battery-powered and explosion-protected portable lamp makes it a unique tool during operations.

The RA responder can be optionally operated with a rechargeable 4.8 V NiCad battery pack or with four alkaline C batteries (Baby) - providing unique flexibility. The Responder RA provides more than two hours of light with the battery pack, with a charging time of two hours using the QuickCharger II, which is included in the scope of delivery. An additional five hours of light are available with battery operation.

No risk of overcharging: The intelligent charging station continuously monitors the charge level of the batteries. The lamp can therefore be kept in the charging as an independent tool. The QuickCharger II charging station includes a spare NiCad battery pack as well as the lamp. The charging system is microprocessor-controlled, and has an LED status indicator.

The robust plastic casing is water spray protected and extremely tough. It can withstand falls from heights of up to 10 m without sustaining damage. With the aid of the sturdy stainless steel jacket clips on the rear of the casing, the lamp can be simply secured to clothing during operations. This keeps the hands free. The lamp head contains two additional spare bulbs. This ensures that you always have a backup if the lamp fails.

Features:

- Robust, indestructible, shockproof and water spray proof nylon housing
- Sturdy jacket and belt clip on rear of casing
- Can be operated with rechargeable battery pack or batteries
- Explosion protection zone I: II 2 G EEx ib e IIB T3
- Two spare bulbs in lamp head
- Universal charger 12/24/230 V
- Spare rechargeable battery pack (optional) can be charged in charger simultaneously
- Extremely good price/performance ratio

Scope of delivery:

- 1 x Responder RA portable lamp
- 1 x NiCad rechargeable battery pack
- 1 x QuickCharger II universal charger 12/24/230 V
- 2 x spare bulbs in lamp head

Technical data:

Luminance:	45,000 Candela
Rechargeable batteries:	NiCad 4.8 V, 1.6 Ah
Bulb:	Halogen
Weight:	450 g (incl. rechargeable batteries)
Dimensions head/D/H:	77 Ø x 70 x 175 mm



1



Supplied without spare battery

2



Order no.	Item	Weight g
1 212440	Responder RA with rechargeable battery and charger	1325
212446	Responder RA with rechargeable battery without charger	500
212448	Responder RA with alkaline batteries	500
212444	Spare rechargeable battery pack	250
212442	Quick Charger II for a Responder RA	875
2 212449	Charging array for four Responder RA's	5500
212445	Shoulder belt for Responder	150



Pocket signal lamp

Well-trying metal torch with integrated signalling function. The red and green filtering lenses are slid over the light outlet using the sliders at the front.

Features:

- Robust metal housing
- Supporting bracket
- Incl. 4.5 V flat battery
- Dimensions 115 x 70 x 35 mm

Order no.	Item	Weight g
212828	Lamp	100
241022	Battery 4,5 V Block/3LR12	170

UK headlamp

1

Personal equipment

Headlamp UK 3AAA LED VIZION

Revolutionary new headlamp concept from UK. The removable and individually usable insert is the special highlight of this new lamp. The lamp can be used in three modes using a rotating filter: focussed, diffused and red light. The module can be used individually when working in difficult areas or used as a tent lamp or reading lamp. The lighting duration is extremely long at 150 hrs, which is achieved using a special method that utilises the heat of the LED lamp to preserve the battery. This also improves operation at extremely low temperatures. The lamp can be switched in two stages. The extremely large switch can even be properly operated wearing thick gloves. The extra-large head band is extremely soft and can be perfectly adjusted - the angle of the lamp on the head can also be properly adjusted using a large knob. The entire structure consists of the best quality materials: ABS, Lexan, rubberised polyurethane and stainless steel. We supply the lamps with brand name alkaline batteries, packed in a blister pack.

Features:

- White high-performance LED
- 100% waterproof and dust-tight up to 10 m
- 150 hours of constant brightness using the special electronics
- Rubberised on/off switch
- Complies with CENELEC (CE) requirements

Technical data:

Alkaline batteries: 3 x AAA
 Output: 1 Watts
 Luminance: 29 lumen
 Operating: 150 hrs.
 Dimensions: 74 x 37 x 46 mm

Scope of delivery:

Lamp with batteries, on blister

Order no.	Item	Colour	Weight g
1 219560	Vizion	black	110
2 219562	Vizion	blue	110
3 219564	Vizion	beige	110
4 219566	Vizion	green	110
5 219568	Vizion	olive	110
241002	Battery AAA/Micro/LR03		15



Headlamp UK 3AAA LED ATEX VIZION [i]

The VIZION with ATEX approval. The perfect headlamp for the professional user. Light output, lighting duration and all features of the UK 3AAA VIZION can also be found in this explosion-proof variant. In order to secure the lamp to a helmet easily and securely, the lamp is equipped with a head band made from special rubber. The rubber ensures that the head band cannot slip off a smooth surface such as helmets, but remains firmly anchored.

Features:

- White high-performance LED
- 100% waterproof and dust-tight up to 10 m
- 150 hours of constant brightness using the special electronics
- Rubberised on/off switch
- Complies with CENELEC (CE) requirements
- EEx protection: certification not yet available at time of printing. Please ask us about this or obtain information from the home page: www.uk-lights.com

Technical data:

Alkaline batteries 3 x AAA
 Output: 1 Watts
 Luminance: 29 lumen
 Operating: 150 hrs.
 Dimensions: 74 x 37 x 46 mm

Scope of delivery:

Headlamp with batteries, on blister



Order no.	Item	Colour	Weight g
219561	Vizion	black	110
219569	Vizion	neon yellow	110
241002	Battery AAA/Micro/LR03		15



More information on our homepage: www.uk-lights.com



Petzl Duo LED 5 headlamp

The name Petzl has stood for top quality products in the outdoor area for years. The same applies to this headlamp. The Petzl Duo is equipped with a halogen spotlight with a maximum range of 100 metres and an LED spotlight with five LED's. The angle of the lamp can be adjusted. The halogen bulb can also be focussed in order to adapt the beam of light to the respective requirements.

Features:

- Powerful headlamp with dual light source (5 LED/1 Halogen)
- On/off switch with switch guard to prevent unintentional activation
- Halogen lamp with adjustable focus
- Angle of lamp can be adjusted
- Stainless steel contacts
- Lamp can also be operated with rechargeable batteries, of course
- Watertight up to 5 m

Scope of delivery:

- 1 x headlamp
- 1 x spare bulb
- 4 x Mignon AA batteries

Order no.	Item	Weight g
240400	Petzl Duo LED 5 headlamp	300
240401	Spare bulb (halogen 6 V)	6
241006	Battery AA/Mignon/LR06	20



Petzl Duo Atex LED 5 headlamp

Many professional users put their faith in Petzl headlamps. This also applies to the explosion-proof model. A successor to the well-tried Petzl Duo, this model is equipped with a focussed, powerful 1 W LED with a maximum range of 50 metres and an LED spotlight with 5 LED's. The angle of the lamp can be adjusted.

Features:

- Explosion-proof lamp with dual light source
- On/off switch with switch guard to prevent unintentional activation
- Angle of lamp can be adjusted
- Stainless steel contacts
- Watertight up to 5 m
- Ex II 2 GD, EEx e ia IIC T3

Scope of delivery:

- 1 x headlamp
- 1 x charger 230 V
- 1 x rechargeable battery pack

Order no.	Item	Weight g
240420	Petzl Duo Atex LED 5	380
240422	Spare rechargeable battery pack	210
240423	12 V vehicle charger	100



Cordless portable floodlight Model 90 A LED

Powerful portable floodlight for the harshest operational conditions.

Features:

- Shockproof and impact-proof casing
- Maintenance free, resistant to continuous charging
- Emergency power function with pilot lamp
- With double insulation
- Protection class II, water spray protected IP44
- Lamp head can be vertically swivelled by 120°
- Extremely stable
- Protected from overloading and deep discharge
- Replaceable lead gel battery
- Casing colour red
- Flash facility
- LED pilot lamp

Technical data:

Range: 100 m
 Lighting duration: 3 h/200 h (pilot lamp)
 Bulb: Halogen 10 W
 Rechargeable battery: 6 V/7 Ah, maintenance free
 Charging time: 18 hrs.
 Dimensions: 126 x 112 x 336 mm

Scope of delivery:

- 1 x replaceable lead gel battery
- 1 x integrated commercial vehicle and charging cable 12/230 V
- 1 x wall bracket
- 1 x extra transparent light diffuser for working light
- 1 x additional coloured lens in orange
- 1 x practical carrying handle

made in Germany



Order no.	Item	Weight g
257610	90 A LED	2600
257620	Spare lamp for 90 A/S	20



AccuLux EX SLE 15

Explosion-proof working and emergency power light in set. Microprocessor-controlled, rechargeable portable floodlight for potentially explosive areas (gas and dust), made from tough plastic. With xenon main lamp and LED pilot lamp. Safety of charging cradle tested in accordance with DIN-EN 1846-2. Approved for vehicles. Can be used as emergency lamp in accordance with VDE 0108.

Explosion

protection class: II 2 G Ex ib II C T4
II 2D Ex ibD 21 T 135° C

Features:

- Water spray protected
- Dust-tight
- Protection class IP64 in acc. with DIN EN 60529 (IEC 529/VDE 047 T1)
- Approved for vehicles (appendix 1.3.2.9 RL 2006/28/EC)
- Extremely bright xenon main lamp with filament break detection
- LED indicator for all switching functions
- EMC tested (PB 006487 01 F)
- Intrinsically safe (in acc. with EN 50020 and EN 61241-11)
- Maintenance-free lead-gel battery
- Main lamp with flashing function
- Safety emergency light function
- Chargeable with 230 V/12/24 V using vehicle power supply connector (cigarette lighter)
- Extremely light (1100 g)
- Lamp head swivels by 110°

Technical data:

Range: approx. 200 m
 Lighting duration: 85 h with extremely economical LED pilot lamp
 Lighting duration: 4 h with 3.2 W xenon main lamp

Scope of delivery:

- 1 x portable floodlight
- 1 x charging station
- 1 x front filter orange
- 1 x front filter transparent
- 1 x 12/24 V cable
- 1 x 230 V cable

Order no.	Item	Weight g
219268	EX SLE 15	1100
219269	Spare xenon bulb 4.0 V/0.8 A	2
219276	Seal ring for reflector	1
219277	230 V power cable	66
219278	12/24 V power cable	39
219279	Spare lens, clear	39
219280	Spare lens, orange	39
219281	LE15 charging station	400
219282	Spare battery 4 V/3.5Ah	500
219283	Belt holder	52



made in Germany



Portable workshop lamp

Workshop lamp, robust version with 5 m cable, impact resistant and shockproof, with double insulation, rotating suspension hook.

Technical data:

Lamp length: 40 cm
 Output: 8 W/230 V

Order no.	Colour	Protection class	Weight g
240450	black	IP23	444
240452	black	IP54	920





Forest worker kit

Robust, cost-efficient version for users of portable chain saws. Extremely light with good, draught-free ventilation.

Features:

- Safety helmet in acc. with EN 397
- 4-point internal fitting with surrounding hat leather
- Hearing protection in acc. with EN 352-3
- Unbreakable spring steel bracket with folding mechanism
- Eye protection in acc. with EN 1731
- Sturdy plastic frame with nylon mesh, hinged
- FPA-tested helmet combination.

Order no.
212550

Weight g
680



Forest worker kit GP 34

Kit for optimum protection of head, face and hearing when working with power saws, hammer drills and the like. Helmet made from UV stabilised, impact-resistant ABS plastic, with safety mesh and ear plugs.

Features:

- Lightweight (350 g) but robust safety helmet in acc. with EN 397 with ergonomic interior fittings
- Ear plugs in acc. with EN 352-3 with optimum fit and excellent hearing protection factor
- Face protection in acc. with EN 1731 with flexible, finemesh nylon
- Additional sun and rain protection

Order no.
212551

Weight g
750



Ear plugs EN 352-2

PU foam plugs with strap, 100 pairs in practical dispensing box. Particularly recommended in areas with a permanently high noise level.

Order no.
212545

Weight g
400

FFP Breathing masks

Fine dust masks in acc. with EN149:2001

FFP1

Filtering half-mask, keeps out solid particles and aqueous aerosols of troublesome fine dust up to 4 times the MAK value.

FFP2

Filtering half-mask, keeps out solid particles and aqueous aerosols of hazardous (slightly toxic) substances up to ten times the MAK value. Available with and without exhalation valve.

FFP3

Filtering half-mask, keeps out solid and liquid particles of toxic, extremely toxic, carcinogenic and radioactive substances up to 30 times the MAK value.

	Order no.	Model	Exhalation valve	Weight g
1	256100	FFP1	no	10
1	256101	FFP2	no	10
2	256102	FFP2	yes	25
2	256103	FFP3	yes	25



Safety goggles EN 166

Universal nylon safety goggles with side guard. Arms can also be adjusted. For work such as cutting, grinding etc.

Order no.	Weight g
280102	40



Full-face safety goggles EN 166

Full-face goggles with adjustable rubber strap. Also suitable for wearing glasses. For work such as cutting, grinding etc.

The model with indirect ventilation is non-fogging. Penetration by dust, particles and liquid spatter is also prevented.

	Order no.	Model	Weight g
1	280100	Direct ventilation	65
2	280101	Indirect ventilation	65

Welder's safety goggles EN 169

With adjustable arms. Universal nylon safety goggles with side guard. Lenses easy to replace with screw. Lens size 50 mm Ø.

Order no.	Weight g
280104	100





From Ergodyne® in the USA - the high-tech glove series for professional emergency services.

The entire series has been completely revised and improved. This glove sets new standards with regard to design and wearing comfort.

Outstanding materials and top workmanship lead to the best test values in acc. with EN 388.

Work glove ProFlex® 710 / 720

The all-rounder for everyday use.

1 ProFlex® 710

Standard five-finger glove for complete hand protection.

Features:

- Visco-elastic gel inlay made from Akton®
- Non-wearing PVC reinforcements on palm of glove and fingers
- Breathing, three-layer back made from Elasthan
- Neoprene knuckle protection
- Flexible zones at knuckles for optimum fit
- Reinforced fingertips for maximum durability
- Woven, extremely flexible cuff
- Patented Hook & Loop fastener for snug fit

2 ProFlex® 720

Two-finger model for full fingertip feel in spite of excellent protection.

Same characteristics as the 710, but the fingertips of the thumb, the index finger and the middle finger are open. Ideal for all "delicate" work.



	Order no.	Model	Size	Weight g
1	259230	710	S	150
1	259231	710	M	150
1	259232	710	L	150
1	259233	710	XL	150
1	259234	710	XXL	150
2	259235	720	S	140
2	259236	720	M	140
2	256237	720	L	140
2	256238	720	XL	140
2	256239	720	XXL	140

Rope work/height rescue glove ProFlex® 740

This top quality safety glove is in our product range specially for rope work and height rescue work.

Characteristics tested in acc. with EN 388:

Abrasion wear	3 (maximum 4)
Cutting resistance	3 (maximum 5)
Tear resistance	4 (maximum 4)
Puncture resistance	3 (maximum 4)

Features:

- Special "grooves" in the palm for rope work with double reinforcement and additional gel pads for a firm grip of the rope
- Additional protection on back from gel padding with Lining made from Amara®
- Double layer reinforcement made from Amara® on fingers, thumbs, knuckles and palm
- Double seams made from Kevlar
- Adjustable strap around wrist for extremely snug fit
- Eye on wrist for convenient glove securing
- Back made from extremely clingy Neoprene fabric
- Machine washable

Order no.	Size	Weight g
259210	S	180
259211	M	180
259212	L	180
259213	XL	180
259214	XXL	180



Ergodyne glove material overview

AKTON®

Is a gel-like visco-elastic polymer plastic compound that has extremely good impact and vibration absorption characteristics.

Amara®

Breathing artificial leather with PU coating. has the same service life and wearing characteristics as real leather, and is machine washable

Keptotec®

is a high-tech fabric that is extremely wear and tear-resistant. For years it has been the best protection fabric to be used in gloves.

Armor-Tex®

One of the strongest and finest fibres in the world. Stronger than steel, longer-lasting than polyester and 40 percent stronger than Aramide

Technical rescue glove ProFlex® 730

Specially developed for operations under extremely difficult conditions - the New York Fire brigade uses this glove when providing technical assistance, for example!

Characteristics tested in acc. with EN 388:

- Abrasion wear 4 (maximum 4)
- Cutting resistance 3 (maximum 5)
- Tear resistance 4 (maximum 4)
- Puncture resistance 2 (maximum 4)

Features:

- Keptotec® inserts in gripping areas and thumb insert provide extremely good durability and additional protection. Keptotec® is outstanding because of its extremely good tear resistance and non-slip characteristics and also provides excellent protection from heat and cold
- Amara® reinforcements in all areas that are particularly subjected to wear
- Double seams made from Kevlar
- PVC-reinforced fingertips for good fingertip feel
- Elasthane back for optimum wearing comfort
- Integrated gel padding for additional protection from damaging vibration
- Extra foam-padded knuckle protection with reflecting inserts
- Palm and thumb made from water and dirt-repelling Amortex®
- Elasticated cuff also protects wrist and prevents penetration by foreign bodies
- Machine washable



Order no.	Size	Weight g
259200	S	180
259201	M	180
259202	L	180
259203	XL	180
259204	XXL	180





Grabber glove clip

The Grabber keeps gloves and tools within reach at all times. The patented clamps will grip almost any material.

This version has a clamp at both sides.

Features:

- Available in four colours: blue, black, neon yellow and neon orange
- Safety predetermined breaking point
- Top quality, sturdy plastic

Order no.	Version	Colour	Weight g
259220	3400	blue	20
259221	3400	yellow	20
259222	3400	orange	20
259223	3400	black	20



Grabber glove clip

The Grabber keeps gloves and tools within reach at all times. The patented clamps will grip almost any material.

This version has a clamp at on side and a belt clip at the other.

Features:

- Available in four colours: blue, black, neon yellow and neon orange
- Safety predetermined breaking point
- Top quality, sturdy plastic

Order no.	Version	Colour	Weight g
259225	3405	blue	20
259226	3405	yellow	20
259227	3405	orange	20
259228	3405	black	20





Work glove

made from pigskin, with lined palm and canvas cuff. Protection class 1.

Order no.	Size	Weight g
256240	10	90

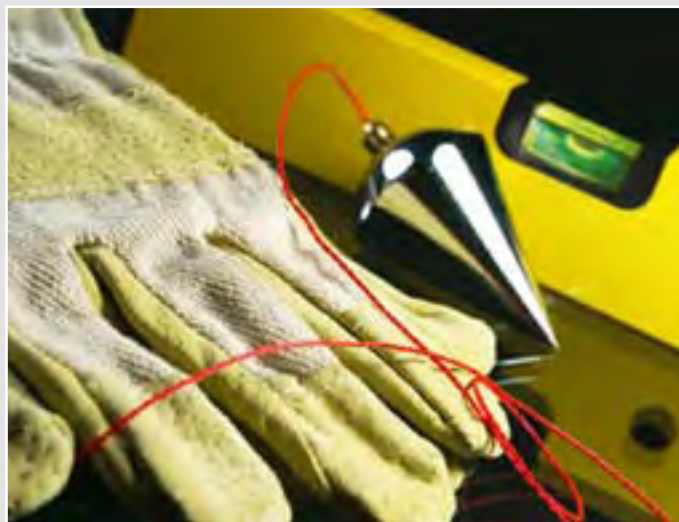

"Elephant" work glove

Made from top quality full-grain leather, lined palm and fingers, double seam, leather index finger, yellow cuff. EN 388.

Order no.	Size	Weight g
256242	10	110



Welder's gloves

Five-finger glove with long cuff, 35 cm long, full-grain leather, complies with EN12477-A category 2.

Order no.	Size	Weight g
256244	10	200

Lightweight chemical protection Glove

This glove, which is made from nitrile, has been specially developed for work where there is a risk of contact with chemical spatter. The glove also provides four times as much puncture resistance as comparable gloves made from natural latex, and is three times stronger than a similar glove made from Neoprene. Powder-free, green, extremely good wet grip properties. Supplied in dispenser containing 100 gloves.

Order no.	Size	Weight g
256232	S	800
256212	M	800
256222	L	800
256223	XL	800



Latex disposable gloves

With rolled edge, seamless, reversible Available with light powdering or powder free. Supplied in dispenser containing 100 gloves.

Order no.	Model	Size	Weight g
256230	Powdered	S	900
256210	Powdered	M	900
256220	Powdered	L	900
256231	Powder-free	S	900
256211	Powder-free	M	900
256221	Powder-free	L	900



Pull-in socks

Warm and comfortable quality made from wool/viscose on the outside and 100% viscose on the inside. Provides a pleasant foot climate in any shoe or boot. Available in sizes 39 to 47.

Order no.	Size	Weight g
280039	39	120
280040	40	120
280041	41	120
280042	42	120
280043	43	120
280044	44	120
280045	45	120
280046	46	120
280047	47	120



"Heavy Duty" S5 safety boots

Seamless, extremely comfortable rubber boots. Ankle padding and the antibacterial inner lining provide a pleasant foot climate, even after long periods of wear. A toecap and the steel intermediate sole protect the foot from "invaders".

Features:

- PVC/rubber mixture, flexible even when cold
- Non-slip sole, oil and alkali resistant and antistatic
- yellow
- 38 cm leg
- EN 345 S5 protection

Order no.	Size	Weight g
281040	40	1200
281041	41	1200
281042	42	1300
281043	43	1300
281044	44	1400
281045	45	1400
281046	46	1500
281047	47	1500



Disposable protection clothing

Before purchasing disposable safety clothing it should be checked which model is suitable for the respective purpose of use.

Disposable safety overalls are basically categorised as follows:

- PSA Category I** Protection from minor risks
- PSA category II** Protection from moderate risks
- PSA category III** Protection from high risks

The overalls in category III are also categorised into:

- Type 5+6**

 - Protection from solid particles
 - Limited protection from liquid chemicals
- Type 4+5+6**

 - Protection from solid particles
 - Protection from liquid chemicals (sprayproof version)
- Type 3+4+5**

 - Protection from solid particles
 - Protection from liquid chemicals (liquid-proof version)

The protective clothing can also provide protection from other risks such as radioactive particles, oil and lubricants, blood and viruses.



Chemical protection overall

Full overall with infection protection from blood and viruses.

- Features:**
- Three-piece hood
 - Elasticated for optimum hood adjustment
 - Three-piece leg gusset
 - Double zip fastener cover
 - Elasticated arms, legs and waist

Colour white.

Protection class:

- PSA category: III, type 5 + 6 
- EN 13982-1: particle-tight
- EN 13034: partially spray water proof
- EN 1073-2: 2002: contamination protection against radioactive particles
- EN 14126: 2003: infection protection against blood and viruses
- EN 1149-1: anti-static
- EN 369: protection from oil and lubricants

Order no.	Size	Weight g
256001	S	350
256002	M	350
256003	L	350
256004	XL	350
256005	XXL	350
256006	XXXL	350

Chemical protection overall type 4, 5 + 6

Features:

- Three-piece hood
- Elasticated for optimum hood adjustment
- Three-piece leg gusset
- Double zip fastener cover
- Elasticated arms, legs and waist
- Thumb loop
- Sealed seams

Colour: white

Protection class:

- PSA category: III, type 4, 5 + 6 
- EN 465: spray proof
- EN 13982-1: particle-tight
- EN 13034: partially spray water proof
- EN 1073-2:2002: contamination protection against radioactive particles
- EN 14126:2003: Infection protection against blood and viruses
- EN 1149-1: anti-static
- EN 369: protection from oil and lubricants

Order no.	Size	Weight g
256016	M	450
256017	L	450
256018	XL	450
256019	XXL	450
256020	XXXL	450



Chemical protection overall type 3, 4, 5 + 6

Lightweight chemical protection overall made from sturdy material with high degree of resistance to chemicals. The overall and the seams are waterproof.

Features:

- Hood with elasticated edges
- Tight mask seal
- Elasticated arms and legs
- Sealed seams
- Zip fastener with double, sealable cover
- Additional removable chin cover
- Thumb loop

Colour: yellow



Protection class:

- PSA category: III, type 3, 4, 5 + 6
- EN 466: watertight
- EN 465: spray proof
- EN 13982-1: particle-tight
- EN 13034: partially water spray proof
- EN 1073-2:2002: contamination protection against radioactive particles
- EN 14126:2003: Infection protection against blood and viruses
- EN 1149-1: anti-static inside
- EN 369: protection from oil and lubricants

Order no.	Size	Weight g
256011	M	500
256012	L	500
256013	XL	500
256014	XXL	500
256015	XXXL	500



TRELLCHEM® Splash Suit Decontamination suit

The Trelchem® Splash Suit full protection suit is a reusable chemical protection suit for providing protection from many different chemicals and hazardous substances.

Unlike protection suits that are worn with a compressed air breathing device, this suit is ventilated by an internal breathing air fan.

The fan draws in ambient air via special safety filters and expels it into the head part of the suit. This generates an overpressure in the entire suit that protects the wearer from penetrating hazardous substances.

Overpressure valves ensure that the internal pressure does not become too high and used-up CO₂ enriched air can escape.

The continuous ventilation of the suit provides a pleasant wearing feeling, and the user can remain in the contaminated area for significantly longer.

No industrial medicine examination in acc. with G26 is required for wearers of this fan filter suit.



In 2009, the state of North Rhine-Westphalia will be purchasing 680 of these suits for the disaster relief services.

Classification:

Cat III / type 3 in acc. with EN 14605

In conjunction with the breathing air fan, the overall also complies with EN 12941.

Features:

- Full protection suit with internal, fully decontaminatable fan filtering unit
- Soft, flexible material, hard-woven polyamide, also with PVC coating on the outside
- All seams fully sealed

Technical data:

Usage

temperature: - 40°C to + 65°C (- 40°F to + 149°F)

Signal colour: bright yellow

Size: Standard size XL, other sizes available on request

The suit has been tested and approved in conjunction with the Scott ProFlow SC 160. Use with other breathing air fans is not permitted.

The recommended filter is the A2B2E2K2 – P3 particle combination filter.

Order no.

256030

Weight g

6000

Face mask:

Face mask with large, expansive field of view (Trelchem "CV" design) made from transparent PVC (thickness 1 mm).



Zip fastener:

Gas and water-tight zip fastener, coated with PVC, horizontally positioned on rear of suit to make the suit easier to put on and take off. The zip fastener is also protected by an external overlap.



Filter for Scott Proflow

Combination filter for use with the Scott Proflow 2 SC for providing protection from particles and all gasses and vapours. If there is any uncertainty about the composition of the hazardous material, always use a combination filter. This filter provides protection from organic, inorganic and acidic gasses, vapours and ammonia, solid and liquid particles, radioactive and highly toxic particles, bacteria and viruses

Classification: A2B2E2K2 – P3 (EN 14387:2004)
ABEK-P SL (EN12941 / 12942)

Two filters are required to operate the fan.

Order no.
256042

Weight g
440



Gloves:

The suit is equipped with latex cuffs for pleasant wearing comfort and the possibility of wearing various gloves (depending on purpose of use).

The cuffs can be adapted to the user by shortening.

Gloves made from PVC, chloroprene, rubber, nitrile or combinations thereof are recommended.



Overpressure valves:

The suit is equipped with a total of 4 overpressure valves that are protected from water penetration.

Boots:

The suit is equipped with PVC safety boots, size 46, tested in acc. with EN 345 S5.



Air supply:

The air supply system consists of: Breathing air hose connected to Blower Air channels inside the hood that allow fresh air to flow against the face mask. Two inlets for screwing the filter to the fan on the inside from the outside parts.

Scott ProFlow 2 SC fan filtering unit

The Scott ProFlow 2 SC belongs to the next generation of fan-assisted respiratory systems. The fan is worn internally in conjunction with the Trelchem Splash Suit, i.e. beneath the suit. The intelligent, easy to use Scott Proflow 2 SC fan unit is also impressive because of its ergonomic and compact design with curved back plate for providing maximum comfort, even during long periods of use. The electronic fan controller regulates the automatic adaptation of the air flow as the filter resistance changes. This ensures that the suit is adequately ventilated at all times. The data storage function in the device records all usage data, in order to provide reliable information about any maintenance that is required when the equipment is being serviced.

Technical data:

Air flow:	min. 160 l/Min
Rechargeable battery:	Ni-MH 9.6V / 4.5 Ah
Operating time:	7-15 hours, depending on filter that is used
Charging time:	6 hours
Display:	battery status (A), Filter capacity exhausted (P)
Acoustic warning:	Low battery - remaining capacity approx. 15 min.
Weight:	1.4 kg (excluding filter)
Noise level:	< 70 dB (A)
Temperature range:	-10°C to +50°C
Certification:	EN 12941 & 12942 (TH1/TH2/TH3/TM3) – CE 0121
Protection class of casing:	IP54S IEC 60529 (water spray protected)

Scope of delivery:

- 1 x fan unit
- 1 x battery, integrated
- 1 x charger
- 1 x comfort belt
- 1 x air hose

Important note:

The fan may only be operated with special filters because of the rapid air flow. Conventional breathing mask filters are not suitable.

Order no.	Weight g
256040	1400



Suitable filters
on page 65



made in Germany

Battery pack for Scott ProFlow SC

For extending the operating time of the ProFlow fan, or for use as an emergency battery. Equipped with lithium ion cells. The battery pack is connected directly to the fan via the charging socket, and tops up the internal fan battery. Watertight casing (IP54) with belt clip.

Technical data:

Voltage:	12 V
Service life:	10 years (at storage temperature of 21° C)
Temperature range:	-40° C to +60° C

Order no.	Weight g
256044	340

exclusive

Waders

made from PVC and polyester with double-sealed seams, 500 g/m², braces adjustable using stainless patented clasps, extremely flexible even at low temperatures.

Welded-on boots with heavily profiled soles, non-slip, with reinforcing ribs on the shaft and reflex point on the heel.

A version with welded on S5 boots, penetration-proof sole and steel toecap is alternatively available.

Order no.	Version	Size	Weight g
256300	Normal boot	40	2600
256301	Normal boot	41	2600
256302	Normal boot	42	3000
256303	Normal boot	43	2800
256304	Normal boot	44	3000
256305	Normal boot	45	3450
256306	Normal boot	46	3500
256310	Safety boot S5	40	3200
256311	Safety boot S5	41	3200
256312	Safety boot S5	42	3400
256313	Safety boot S5	43	3500
256314	Safety boot S5	44	3700
256315	Safety boot S5	45	3900
256316	Safety boot S5	46	4000



Rainproof clothing EN 471 High-Vis

Perfect protection, even under adverse external conditions. The breathing, tear-proof and cold-resistant polyester material (170 g) is coated with polyurethane. The reflective strips are made from original 3M Scotchlite. The clothing can be washed at 30 °C.

1 High-Vis rain jacket, EN 471-3

Jacket with covered zip fastener and pocket flap with press studs and additional back ventilation. The hood has an internal draw cord and can be stowed away in the collar. Two external pockets with pocket flap. Elasticated sleeve with additional Hook & Loop fastener. With hem adjuster. Stretchable material makes the jacket extremely comfortable to wear.

Order no.	Colour	Size	Weight g
256410	Fluorescent orange	S	620
256411	Fluorescent orange	M	640
256412	Fluorescent orange	L	700
256413	Fluorescent orange	XL	720
256414	Fluorescent orange	XXL	720
256415	Fluorescent orange	XXXL	760

2 High-Vis rain trousers, EN 471-1

Comfortable rain trousers for wearing over normal trousers. Width of trouser bottoms adjusted using Hook & Loop and zip fasteners. With hem adjuster. Stretchable material makes the trousers extremely comfortable to wear.

Order no.	Colour	Size	Weight g
256400	Fluorescent orange	S	380
256401	Fluorescent orange	M	380
256402	Fluorescent orange	L	385
256403	Fluorescent orange	XL	420
256404	Fluorescent orange	XX	480
256405	Fluorescent orange	XXXL	480

HangAir®

The HangAir® uses a waterproof, high-power fan to dry suits of any kind in just a few hours. Enjoy the luxury of a freshly ventilated suit for your operation or dive. The HangAir® dries the inside of the suit before storage - also removing odours and extending the service life of the suit. The HangAir® is made from strong plastic, and the steel hook can bear weights of up to 50 kg. The connecting cable is a convenient 5 m in length. The fan operates at a safe low voltage.

Features:

- Dries clothing, rainwear, diving suits etc. in hours rather than days
- The watertight fan generates an air flow of 4 m³ per minute
- Wide supporting surface in shoulder area prevents damage to the material

Technical data:

Fan: 230 V
 Dimensions: 576 x 361 x 180 mm
 Capacity: 45 kg

Scope of delivery:

Hanger and 230 V power supply

Order no. **219670** Weight g 2450



Super hanger clothes hanger

Extremely sturdy clothes hanger for emergency services and work clothing. The load-bearing capacity of up to 10 kg means that the hanger can support soaking wet clothing without problems.

Features:

- Dries clothing, rainwear, diving suits etc.

Technical data:

Capacity: 10 kg
 Dimensions: 30 x 421 x 228 mm

Order no.	Colour	Weight g
219672	yellow	260
219676	black	260

Super BC clothes hanger

Extremely sturdy clothes hanger for emergency services and work clothing and compressed air breathing apparatus. The shoulder belts of compressed air breathing apparatus will not slip off the sides, breathing air hoses can also be secured to the T-shaped hook at the bottom of the hanger.

Features:

- Dries clothing, rainwear, diving suits etc.

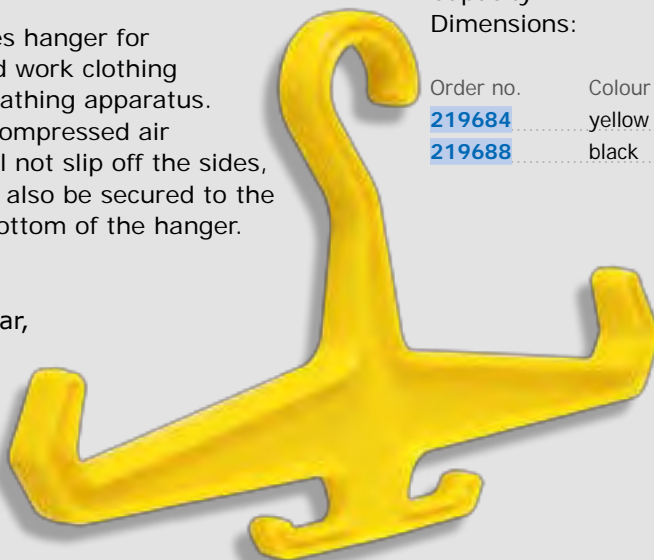

Technical data:

Capacity: 10 kg
 Dimensions: 30 x 406 x 254 mm

Order no.	Colour	Weight g
219684	yellow	260
219688	black	260

Super Accessory clothes hanger

Sturdy hanger for boots, gloves, shrouds etc.

Features:

- Dries clothing, rainwear, diving suits etc.

Technical data:

Capacity: 10 kg
 Dimensions: 30 x 330 x 508 mm



Order no.	Colour	Weight g
219690	yellow	305
219694	black	305

5.0 Exposure Suit clothes hanger

This extra-wide (127 mm) hanger makes it easier to dry all diving suits and emergency services clothing. It keeps the clothing in a natural shape and therefore has an excellent ventilation and drying effect. Creases and pressure points are prevented. The second, lower hanger is for trousers and under-clothes.

Features:

- Dries clothing, rainwear, diving suits etc.

Technical data:

Capacity: 22.5 kg
 Dimensions: 127 x 381 x 406 mm

Order no.	Colour	Weight g
219682	black	500



Slings

These extremely strong, continuous slings can save lives during operations. Because of their small dimensions and light weight, they can be carried at all times in a multifunction holster, for example. Useful for rescuing injured persons, for self-anchoring or as an additional aid when using various tools.

Features:

- High quality strap material
- Continuous strap
- Complies with EN 795, class B
- Width 25 mm
- Tensile strength 2500 daN

Order no.	Length/circumference cm	Weight g
262002	60/120	100
262004	120/240	190
262006	150/300	230
262008	180/360	270
262010	200/400	300



DIN 14927 fire brigade safety belt with multifunctional eye

Complies with the new, revised DIN 14927. All belts with two-hole buckle.

The belts are optionally equipped with karabiners with screw locking devices or Twistlocks.

1 Model A clamping frame

Order no.	Karabiner	Size	Weight g
221005	Twistlock	1	1000
221010	Twistlock	2	1010
221015	Twistlock	3	1030
221020	Twistlock	4	1050
221025	Screw locking device	1	1000
221030	Screw locking device	2	1010
221035	Screw locking device	3	1030
221040	Screw locking device	4	1050

2 Model B with leather reinforcement

Order no.	Karabiner	Size	Weight g
221045	Twistlock	1	1000
221050	Twistlock	2	1010
221055	Twistlock	3	1030
221060	Twistlock	4	1050
221065	Screw locking device	1	1000
221070	Screw locking device	2	1010
221075	Screw locking device	3	1030
221080	Screw locking device	4	1050

Fire brigade rope (rescue rope) DIN 14920

Made from top quality polyester, with spiral plaiting, 10 mm Ø.

Type F xx-H:

Wooden toggle at one end, 90 mm Ø eye splice at the other end.

Type F xx-K:

A10 cable eye stiffener and karabiner hook at one end, 90 mm Ø eye splice at the other end.

Order no.	Item	Length m	Weight g
212610	F 20-H	20	1400
1 212615	F 30-H	30	2200
212620	F 20-K	20	1600
212625	F 30-K	30	2300



Multipurpose line (working line) DIN 14920

Made from red Perlon, with spiral plaiting, 10 mm Ø.

Type A 20-H:

Wooden toggle at one end, 90 mm Ø eye splice at the other end.

Type A 20-K:

A10 cable eye stiffener and karabiner hook at one end, 90 mm Ø eye splice at the other end.

Order no.	Item	Length m	Weight g
1 212650	A 20-H	20	900
212655	A 20-K	20	1100



Fire brigade rope bag DIN 14921

Brown impregnated sailcloth compliant with new DIN 14921, for F20 and F30 rescue ropes, with flap and catch and rings for rescue rope and additional karabiner.

Order no.	Version	Weight g
212630	In acc. with DIN 14921	250

Rescue rope bag carrying line

Made from Perlon with two karabiners. The carrying line is secured to the rescue rope bag using the karabiners. The bag can then be carried on the back, at the front or over the shoulder.

Order no.	Length cm	Weight g
212632	100	100



made in Germany

Fire brigade karabiner DIN 5299C

Galvanised version, polished.

Order no.	Dimensions mm	Weight g
212909	5 x 50	22
212910	6 x 60	27
212915	8 x 80	63
212920	10 x 100	128
212925	11 x 120	190
212930	12 x 140	260



HMS karabiner

HMS karabiners are widely used karabiners for the dynamic securing of other climbers. HMS stands for half hitch belay. HMS karabiners are locking karabiners that have a pear-shaped design. This design makes it easier to carry out the half hitch belay. The HMS karabiner in our product range is made from top quality aluminium. Minimum breaking strain 24 kN longitudinal, 8 kN with gate open, 11 kN lateral.

Order no.	Dimensions mm	Weight g
212921	112 x 72	97



DOENGES exclusive



Waist belt with under-belt Pax®

The American-style waist belt can be Hook & Loop-fastened to the under-belt that is threaded through the belt buckles immediately before use, fully equipped with holsters and BTM ampoule bags, for example.

Order no.	Length cm	Weight g
266035	90	150
266036	105	150
266037	120	150
266038	135	150



"Limburg" respiratory holster

Relatively high belt holster that is specially designed to hold long equipment items such as Cologne rescue scissors, light sticks or a new building key. A sling with HMS karabiner, a marker pen or wax chalk and two wooden wedges will also fit in the holster.

Order no.	Material	Dimensions	Weight g
263005	PAX®-Dura, black	180 x 120 x 80 mm	210



Example configuration
Supplied without contents

"Heidelberg" shoulder belt holster

Classic emergency holster for securing to shoulder belt of respiratory device. Can be opened with a single hand movement, and the Cologne rescue scissors are immediately ready to hand. The binding strap prevents the scissors from being lost.

Order no.	Material	Dimensions	Weight g
263008	PAX®-Dura, black	50 x 220 x 25 mm	55

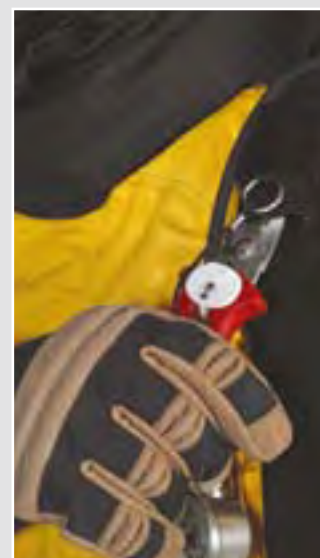

Example configuration
Supplied without contents



Suitable scissors
on page 28

"Darmstadt" respiratory holster



Slimline belt holster for a rescue knife or UK torch, a sling with HMS karabiner, a marker pen or wax chalk and two wooden wedges.

Order no.	Material	Dimensions	Weight g
263006	PAX®-Dura, black	140 x 90 x 60 mm	90



Example configuration
Supplied without contents



Multipocket, large

The original, and the source of all firePAX® holsters. Two identical compartments for a (rescue) knife or multitool and a UK torch or marker pen/wax chalk. Suitable as basic equipment on a respiratory device or as a classic service holster for all emergency services.

Order no.	Material	Dimensions	Weight g
263010	PAX®-Dura, black	140 x 100 x 40 mm	90



Example configuration
Supplied without contents



"Karlsruhe" respiratory holster

The well-tryed "Large multi-pocket" has had a sling compartment added at the front. This version has room for a rescue knife or UK torch and a sling with HMS karabiner. The flap now also has two compartments for marker pens or wax chalk, and two wooden wedges can be accommodated at the side.

Order no.	Material	Dimensions	Weight g
263004	PAX®-Dura, black	160 x 120 x 60 mm	150



Example configuration
Supplied without contents



Director of operations bag Pax®

Maps, operational documents, hospital plans, operational or service plans, radio, writing materials and more can be accommodated in this compact bag. A suspension file provides a quick overview. Practical suggestion have led to this considerably revised new version, in which the size of the rear outer pocket can be adjusted.

Dimensions: 53 x 25 x 27 cm

Order no.	Material	Colour	Weight g
266025	PAX®-Dura	red	2900
266026	PAX®-Dura	blue	2900
266027	PAX®-Plan	red	3000
266028	PAX®-Plan	blue	3000

 Material information on pages 280-281

Fire brigade clothing bag Pax®

Bigger clothing bag version for firemen's equipment (including helmet), which is usually bulkier.

Dimensions: 65 x 38 x 25 cm

Order no.	Material	Colour	Weight g
266033	PAX®-Dura	red	1900
266034	PAX®-Dura	blue	1900



Fire brigade backpack

Stylish, practical backpack with padded shoulder straps and padded rear.

Two additional outer pockets wit zip fasteners and external mobile phone holder. Embroidered fire brigade emblem with "FEUERWEHR" lettering with individual lettering on request.

Ideal as a gift for big and small firefighters.

Order no.	Weight g
212594	600

Fire brigade leather bag

Made from black leather. With writing material holder and two belt loops. Optional leather shoulder belt available.

Order no.	Item	Dimensions mm	Weight g
212590	Leather bag	240 x 220 x 40	320
212592	Shoulder strap		70



made in Germany

Rear view

Chalk marker



made in Germany

exklusiv DÖNGES

Ideal holder with pressure mechanism for pieces of marking chalk with 11 - 12 mm Ø.

The chalk is protected from impacts and moisture, and falls out of the octagonal plastic casing at the push of a button. For marking doors, safe areas etc.

Order no.	Dimensions mm	Weight g
280060	120 x 18	30

Marking chalk



Hexagonal wax marking chalk, available in four colours. The chalk fits into the chalk gravity marker and will also write on a wet surface. Ideal for use by the fire brigade.

Order no.	Colour	Length mm	Weight g
280062	blue	110	20
280064	red	110	20
280066	white	110	20
280068	yellow	110	20

Compass

Precision compass with liquid damping, in metal housing. Well tried under the harshest of conditions.

Order no.	Closed dimensions mm	Weight g
212904	80 x 57 x 31	100





Breathing air cylinder, steel, 6 l

Compressed air cylinder for use on respiratory device, operating pressure 300 bar, 6 litre capacity. Steel cylinder with valve connection M18 x 1.5. With rotary valve and sealing plug.

Supplied with CE marking, conformity declaration in compliance with 97/23/EC (pressure equipment directive) and testing before start-up in accordance with §14 BetrSichV.

These breathing air cylinders have a specially developed turning handle whose special shape reliably prevents the valve from being closed unintentionally during operations. The valve cannot be accidentally turned and closed by scraping it against a wall or due to friction in the CSA.

The cylinder is supplied empty.

Technical data:

Gas type:	breathing air
Material:	CrMo steel
Painting:	yellow, neck black/white quartered
Max. permissible operating pressure:	300 bar
Capacity:	6 l/content 1800 l
Test pressure:	450 bar
Usage temperature range:	-30° C to +60° C
Test interval:	5 years

Order no.	Size Ø mm x mm	Weight kg
220500	140 x 615	8,9



Breathing air cylinder CFK 6.8 l

For use with respiratory device. Due to the use of the latest materials, a weight reduction of about 40% can be achieved with this cylinder compared to conventional steel cylinders.

Valve connection M18 x 1.5. With turning valve and sealing plug.

Supplied with CE marking, conformity declaration in compliance with 97/23/EC and testing before start-up in accordance with §14 BetrSichV.

The cylinder is supplied empty.

Technical data:

Gas type:	breathing air
Material:	CFK
Painting:	yellow, neck black/white quartered
Capacity:	6.8 l/2,040 l
Permissible operating pressure:	max. 300 bar
Test pressure:	450 bar
Usage temperature range:	-30° C to +60° C
Test interval:	5 years

Order no.	Size Ø mm x mm	Weight kg
220502	156 x 590	4,8





Tools with outstanding quality are our specialty. We have been dealing with all kinds of tool for more than 100 years, from screwdrivers to special tool kits for the fire brigade and the THW.



Portable tools/ Breaking & Unlocking tools

Hammers/Club hammers/	Breaking tools	93-94
Chisels 80-82	Opening tools	95-100
Hatchets 83	Pliers	101-102
Multifunction tools 84-86	Bolt cutters	103
Axes/Bricklayer's hammers 87-89	Wrenches	104-106
Hooligan tools 90-92	Screwdriver	107
Crowbars 92	Saws	107-108



Hooks/Shovels/ Hoes/Brooms

Ceiling hooks 109	Hoes/Forks	116
NUPLA tools 110-113	Brooms	117-119
Shovels 114-115	Rubber squeegee	119



Toolboxes/ Cases

Transport	Zarges Euro-boxes	129-131
Stacking box 120-121	Dönges fire box	132-136
Watertight	Tool kits	137-146
UK boxes 122-128	Tool case	147-148



Power tools

Battery-powered screwdriver 149-150	Angle grinders	155-156
Cordless hammer drills 151-152	Jig saws	157-159
Hammer drills and chisel hammers 153-154	Measuring devices	160



Equipment for providing technical assistance

Plasma cutter 161-162	Airbag securing systems	170-171
Cutting torch 163	Multipurpose hoist sets	172-175
Work platform 164	Wooden supports	176-177
Ladders 165	Drive-on aids	178
Glass management 166-168	Winches/supports	179-180
Safety blanket set 169		



Auxiliary equipment

Canisters 181-182	Screws/Nails/	
Buckets/Basins 183-184	Dowels	186-188
Ropes/Shackles 185	Adhesive tape	189



Engineer's hammer DIN 1041

Head painted black, with ash handle.
Solid quality, even for continuous heavy use.

Order no.	Size g	Weight g
280502	300	380
280504	500	620
280506	1000	1150



Engineer's hammer, non-sparking

Made from special bronze, similar to DIN 1041, fine sandblasted surface, with hickory handle.
For use in potentially explosive areas.

Order no.	Size g	Weight g
285502	300	380
285504	500	620
285506	1000	1150



Roofing hammer DIN 7239

With roughened face and claw, fibre glass handle, non-slip rubber grip.

Order no.	Length mm	Weight g
280530	310	600



Blacksmith's chisel DIN 5107

Head painted black, made from chisel steel with ground cutting edge and straight ash handle

Order no.	Length mm	Weight g
210250	600	2200

Sledge hammer DIN 1042

Head painted black, with ash handle.
Extremely sturdy version for the heaviest of use.

Order no.	Size g	Weight g
280522	3000	3400
280524	5000	5500
280526	6000	6500



Club hammer DIN 6475

Head painted black, with ash handle.
Robust import quality.

Order no.	Size g	Weight g
280512	1000	1150
280514	2000	2200



Club hammer, non-sparking

made from special bronze, similar to DIN 6475,
fine sandblasted finish, with hickory handle.
For use in potentially explosive areas.

Order no.	Size g	Weight g
285512	2000	2200



Copper hammer, non-sparking

With ash handle. For use in potentially
explosive areas.

Order no.	Size g	Weight g
210110	1000	1150
210115	2000	2200



Rubber mallet DIN 5128

Flat at both sides, with painted ash handle.

Order no.	Size Ø mm	Weight g
280534	55	340
280536	65	560
280538	75	740



Wooden mallet DIN 7462

Made from white beech, natural, with glued-in
handle.

Order no.	Size Ø mm	Weight g
210255	90	1152
210256	80	902
210257	70	560



Punch DIN 6458

Octagonal shaft made from CV steel.

Order no.	Ø mm	Weight g
280420	3	60
280422	5	60



made
in
Germany

Pin punch DIN 6450

Octagonal shaft made from CV steel.

Order no.	Ø mm	Weight g
280424	2	65
280426	3	70
280428	4	70
280430	5	75
280432	6	80
280434	8	115



made
in
Germany

Flat chisel DIN 6453

Quality flat chisel in acc. with DIN 6453 made from chromium vanadium steel. Drop forged, annealed head.

Order no.	Length mm	Width mm	Weight g
280402	150	17	180
280404	175	20	280
280406	200	23	390
280408	250	23	490
280410	300	23	600



made
in
Germany

Chisel hand guard

Made from non-slip black rubber, suitable for octagonal and flat chisels.

Order no.	Weight g
280412	110

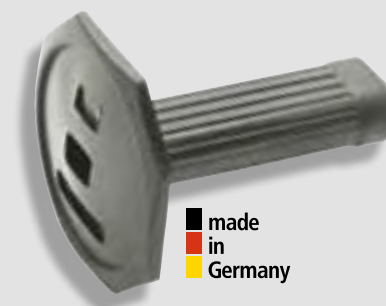

made
in
Germany

Flat chisel, non-sparking

Made from special bronze, fine sandblasted surface, with rubber hand guard. For use in potentially explosive areas.

Order no.	Length mm	Width mm	Weight g
285402	200	23	270
285404	250	25	520
285406	300	27	660
285408	400	30	1350



made
in
Germany

exclusive

Hatchet DIN 5131

Kitchen hatchet, 600 g, with ash handle.
Quality hatches for all types of use.

Order no.	Length mm	Weight g
280440	430	800



Claw hammer

In acc. with BW-TL 5110-0004, painted head with ground cutting edge and nail claw and hammer head at other end, with ash handle.

The nail claw that is integrated in the head of the axe opens up additional uses for the tool.

Order no.	Length mm	Weight g
202090	370	1000

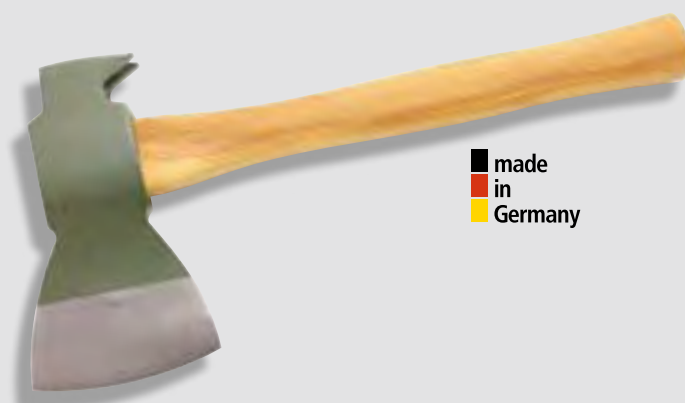

made
in
Germany



Manhole hammer

Special hammer for easy lifting and opening of manhole and hydrant covers.

Features:

- Specially forged tip, suitable for all manhole and hydrant covers
- Steel tube handle
- Non-slip rubber grip

Order no.	Length mm	Weight g
218078	320	500



made
in
Germany

Paratech prying tool

Lightweight multifunction tool for a wide range of tasks. Can be used as an axe, sheet metal ripper, door and lock breaker etc. Pressing the buttons beneath the rubber handle releases the extension handle, which can be fully or partially extended. Manufactured from hardened steel with chemically nickelplated finish, including nylon belt bag.

Functions:

- Axe blade
- Nail remover
- Sheet metal ripper
- Impact tip

Order no.	Length closed/extended mm	Weight g
202060	380/480	1500

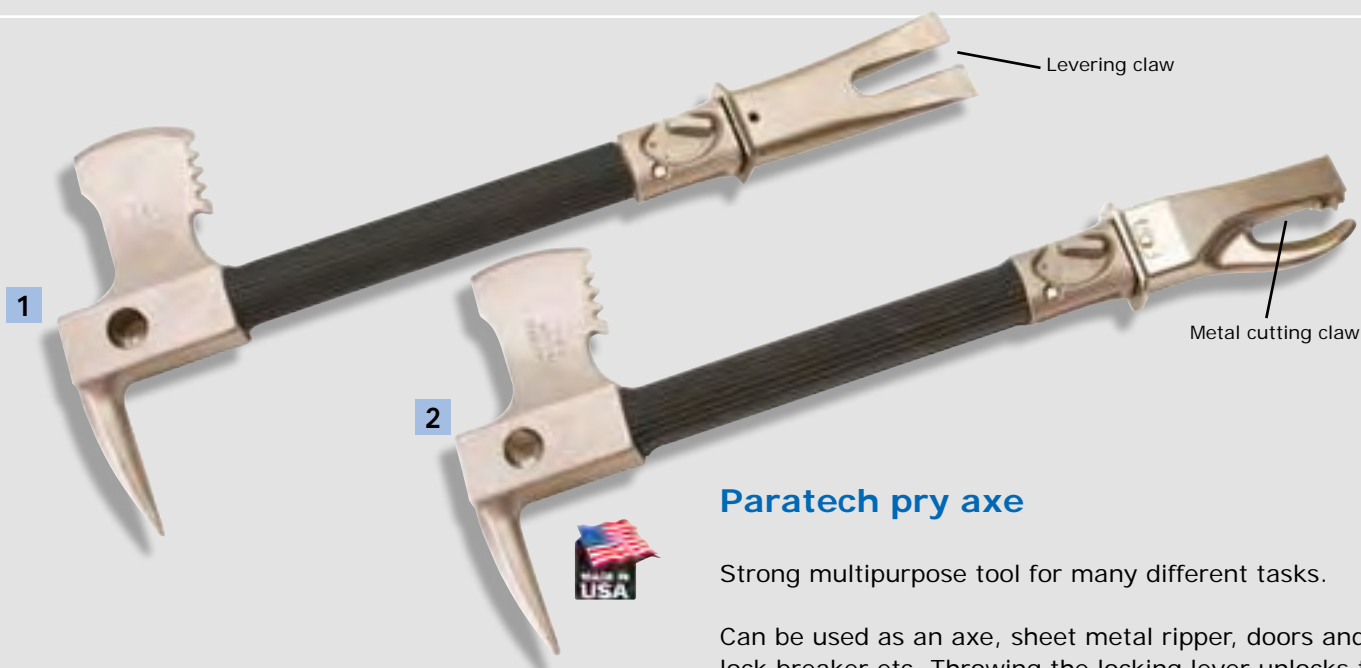

Paratech pry axe

Strong multipurpose tool for many different tasks.

Can be used as an axe, sheet metal ripper, doors and lock breaker etc. Throwing the locking lever unlocks the extension handle, which can be fully or partially extended.

Manufactured from hardened steel with chemically nickel-plated finish. Two different versions are available, with levering claw or metal cutting claw.

Functions:

- Axe blade
- Nail remover
- Levering claw or metal cutting claw
- Impact tip

Order no.	Model	Length closed/extended mm	Weight g
1 202063	Levering claw	470/655	3000
2 202065	Metal cutting claw	475/660	3000



Buster tool

This small, extremely compact tool is ideal for starting the job. This sturdy version can also be used reliably in the harshest of conditions. A non-slip rubber handle provides a good grip in any situation. The various integrated tools provide a solution to the majority of problems.

The handle of the Buster tool can be extended by pressing a button. The longer lever that is created increases the amount of force that can be exerted on the tool many times. Even locked doors can be levered open.

Can also be used as a hatchet, nail remover, lock breaker or sheet metal ripper.

Functions:

- Axe blade
- Impact tip
- Extremely compact levering claw
- Ergonomically designed, rubberised handle

Order no.	Length closed/extended mm	Weight g
202061	394/546	2800



Force rescue equipment

Indispensable rescue device for fire brigades and rescue services.

Can be used as a hatchet, sheet metal ripper, door and lockbreaker etc.

Versatility, handy size, non-sensitivity, rapid access to all functions are the outstanding features of this rescue equipment.

Made from hardened, special steel alloy. Consists of rescue tool (two-piece axe and claw part), rescue and carrying strap, stable vehicle holder and detailed operating instructions on CD.

Functions:

- Cutter
- Nail remover
- Levering bar
- Hardened impact tip
- Sheet metal cutter
- Extendable for added levering force
- Adjustable carrying strap for easy and safe carrying
- Vehicle holder for safe transport in the emergency vehicle

Order no.	Length closed/extended mm	Weight g
202080	560/840	4200

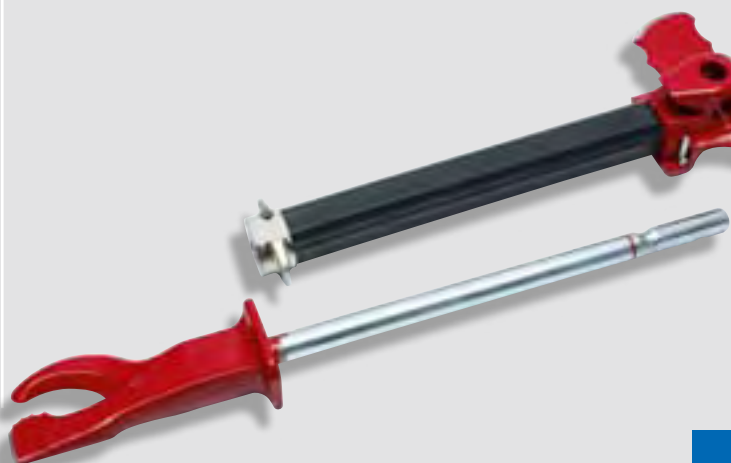

SOS Rescue Tool Kit

The SOS Rescue Tool Kit is a multifunctional tool kit that weighs just 2.9 kg and contains twelve different tools in a handy and sturdy kit.

The kit is made from top quality steel. The six different components of the kit can be carried in a practical belt holster. The constituents of the kit can be assembled into the following twelve tools:

Functions:

- Crowbar
- Hammer
- Sheet metal opener
- Metal saw
- Wood saw
- Knife
- Sledge hammer
- Chisel
- Spades
- Axe
- Hoe
- Ground anchor

The number of application for the individual combinations are simply unlimited: from simple seat belt cutting to sheet metal cutting, cutting tubes over the door opening to cutting vehicle pillars, versatile isn't the word for this tool. The full diversity of this SOS Rescue Tool Kit only becomes properly evident after it has been tried out and used many times.



- 1 Handle
- 2 Handle extension
- 3 Axe blade with wood sawing blade
- 4 Sheet metal cutting claw with metal saw blade
- 5 Levering claw
- 6 Spade

Order no.	Item	Weight g
202074	SOS Rescue Tool Kit with holster	2900

Spare parts for FA fire brigade axe

These spare parts are needed to replace the handle of the german fire brigade axe.

The following are also required to replace the handle:

- 2 x springs
- 1 x wooden wedge
- 2 x ring wedges
- 1 x rivet

Order no.	Item	Weight g
201010	Spare handle with full installation kit	750
201015	Spare handle	500
201020	Spring	100
201025	Rivet	10
201030	Wooden wedge	10
201035	Ring wedge	20

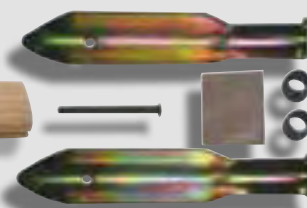

Fire brigade axe DIN 14900 FA

The classical german fire brigade axe - top quality, sturdy version. Red-painted head with ground gap cutter and lever cutter at other end.

With oval hickory handle with transparent varnish.



The axe head is secured with two springs, one rivet and two ring wedges.

Order no.	Length mm	Weight g
201001	900	2500

Fire brigade axe DIN 14900 FAK

As above, but with glued-in fibre glass handle and non-slip rubber grip.

Features:

- Fibre glass is insensitive to moisture, many chemicals etc.
- Handle is almost indestructible
- Non-slip rubber grip

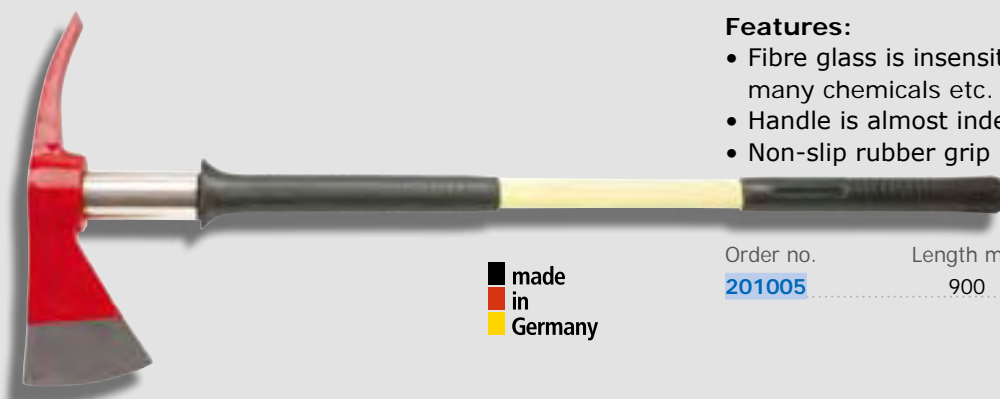

made
in
Germany

Order no.	Length mm	Weight g
201005	900	3000

Fire brigade axe with Ultratec handle

The axe head is identical to the one of the DIN 14900-FA fire axe, but this axe is equipped with an Ultratec fibre glass handle. This means extremely good stability with a good price-performance ratio. The grip of the handle is rubberised to provide a better grip.

Order no.	Length mm	Weight g
201009	900	2600



made
in
Germany

Fire brigade axe with NUPLA handle

The special manufacturing procedure and the extremely high proportion of glass fibre makes this handle almost unbreakable. A rubber handle at the end provides the necessary grip.

Order no.	Length mm	Weight g
201007	900	2400

 More information about NUPLA handle can be found on page 110

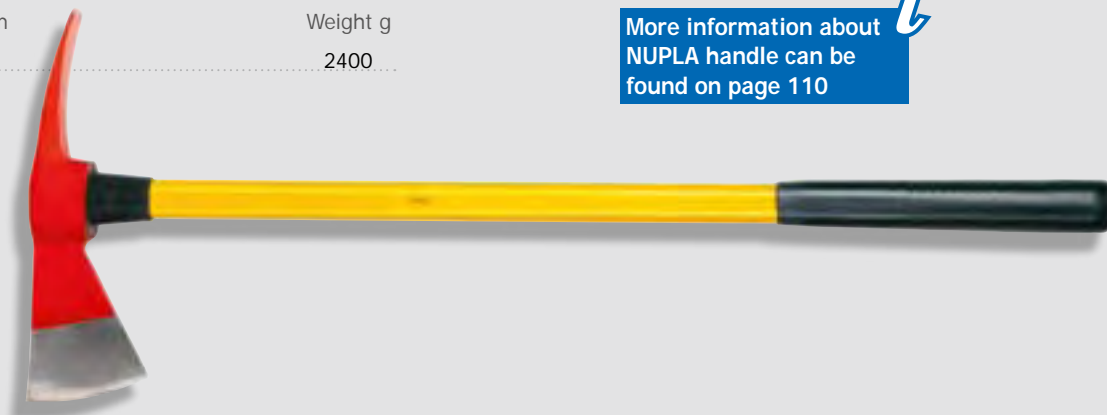

Protective bag DIN 14900

For all fire brigade axes, made from black full-grain cow's leather with carrying strap.

Order no.	Weight g
201040	360



made in Germany

Supplied without axe

Woodcutting axe DIN 7294 B2

Berlin design, head painted red, with ash handle.

Order no.	Item	Length mm	Weight g
202050	Woodcutting axe	900	2700
202051	Spare handle	900	700



exclusive 

Splitting hammer

Quality splitting hammer with ash handle.
Cost-effective and robust.

Features:

- Sturdy ash handle
- Extremely good price/performance ratio



Order no.	Length mm	Weight g
201006	900	4200

Splitting hammer with fibre glass handle

Quality splitting hammer with fibre glass handle. Head and handle are virtually inseparable, therefore proving additional safety and a long service life.

Features:

- Extremely strong
- Extremely good insulation against voltage
- Extremely good insulation against heat and cold
- Long service life, no material ageing
- Hammer head almost inseparable from handle
- Extremely good price/performance ratio

Order no.	Length mm	Weight g
201008	900	5900



Splitting wedges

Made from top quality steel

with guide groove.

Order no.	Material	Length mm	Weight g
202092	Steel	260	2500

Made from aluminium

with slits and guide groove

Order no.	Material	Length mm	Weight g
202091	Aluminium	215	550

Made from PE plastic

Order no.	Material	Length mm	Weight g
202096	Plastic	245	500

PARATECH

started production of the globally renowned **Pry Axe** in 1963.

This was followed by the **Hooligan Tool** in 1965, which was the first industrially manufactured tool with the "**Halligan**" design.

The product range was continuously extended and improved in the years that followed. As well as hooligan tools, the product range now includes support systems and lifting cushions.

Paratech tools have played a decisive part in the rescue work that has taken place at the majority of earthquake sites over the last few years.

The range of hooligan tools is extremely comprehensive and leaves nothing to be desired:

- Many different lengths
- Different claw shapes
- Different materials: Steel, aluminium, non-sparking copper beryllium
- Tactical black finish available on request



Metal cutting claw, also for strong materials



10 year guarantee on all hooligan tools

Hooligan tool

The globally known multifunction hooligan tool. For breaking open doors, windows etc.

Can be used as a crowbar and pinching bar, for spreading and ripping open.

Made from hardened steel with chemically nickel-plated finish and corrugated handles (25 mm Ø).

Two versions are available:

Lever claw - ideal for breaking things open

Metal cutting claw - ideal for use at traffic accidents



Order no.	Model	Length mm	Weight g
211519	Levering claw	610	4500
1 211520	Levering claw (standard)	762	5200
211521	Levering claw	914	5800
211522	Levering claw	1067	6400
2 211525	Metal cutting claw	762	5200
211526	Metal cutting claw	914	5800
211527	Metal cutting claw	1067	6400
211528	Carry strap for hooligan tool		900

Lightweight hooligan tool

Lightweight versions of the well-tried hooligan tools from Paratech are also available.

The extremely strong aluminium alloy provides a significant weight reduction compared to conventional hooligan tools.

Stability is guaranteed, of course.

An alternative to adding personal equipment: the reduced weight means that it can always be carried on your person.

Order no.	Model	Length mm	Weight g
211530	Levering claw	610	3200
211532	Levering claw	762	3500
211528	Carry strap for hooligan tool		900



Kelly Tool

Known as the "Westcoast Bar" in the USA. Slightly different version of the hooligan tool without impact journal, with bigger wedge/hammer head and lever claw.

Manufactured from hardened steel with chrome plated finish and corrugated handles (25 mm Ø).

Order no.	Model	Length mm	Weight g
211536	Kelly Tool	762	5400
211538	Kelly Tool	914	5900
211540	Kelly Tool	1067	6600
211528	Carry strap for hooligan tool		900

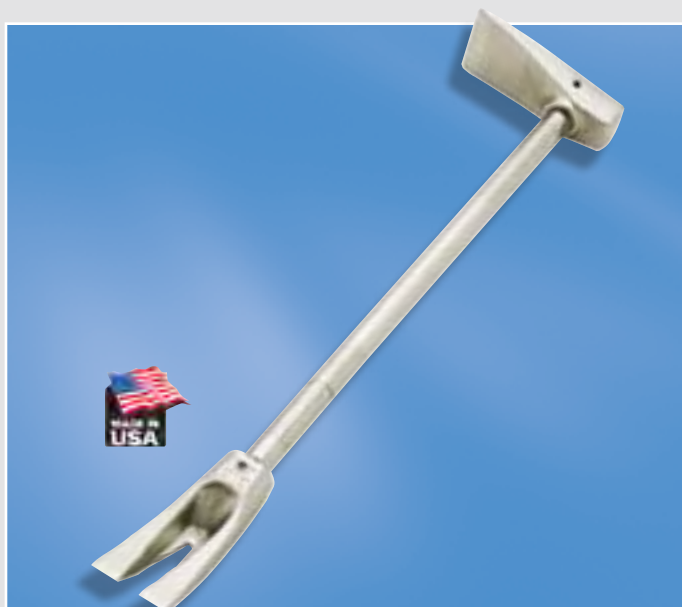

TNT tool

The TNT tool replaces conventional tools such as axes, crowbars, tearing hooks, rams, mortise chisels and sledge hammers. The extremely strong quality steel with black powder coating and the NUPLA fibre glass handle give this tool tremendous stability. The ergonomic handle makes it easy to take advantage of the many different uses of this tool. Easy to carry, easy to use!

Functions:

- Opening doors and windows
- Making holes
- Tearing open walls and ceilings
- Knocking off screws
- Beating down stakes/posts etc.

Order no.	Length mm	Weight g
211524	1020	6100



More information about NUPLA handle can be found on page 110



Hooligan tool combinations

The extremely versatile hooligan tool has even more penetrating capability in many situations due to the use of supplementary tools. This makes initial responses significantly easier and quicker if heavy doors have to be broken down, for example, since the pike of the hooligan tool is easier to insert into the gap using the splitting hammer. In order to make the tools easier to carry, a special carrying strap has been developed that connects the hooligan tool to a splitting hammer or TNT tool and makes them easy to carry over the shoulder. Two meaningful combinations can therefore be put together: standard hooligan tool with lever claw, length 762 mm, either with splitting hammer with fibre glass handle, length 900 mm or with a TNT tool, length 1020 mm and a carrying strap for both tools.

Features:

- Additional deployment options by combining two tools
- Increased penetration force
- Easy to transport using special carrying belt
- Indestructible materials for long service life

Order no.	Item	Weight g
211531	Hooligan/splitting hammer combination	9480
1 211533	Hooligan/TNT tool combination	11640
211529	Carrying system for combination	340



Crowbar DIN 14853

The classical heavy fire brigade crowbar. Available in three lengths.

made in Germany

exclusive **DOENGES**



Features:

- Painted black
- Hardened tip at one end, bent, hardened claw at the other end

Order no.	Length mm	Ø mm	Weight g
210310	700	30	3500
210315	1200	30	6200
210320	1500	30	8000

Carpenter's crowbar

Lightweight pinching bar for a wide range of tasks.

Features:

- Made from hexagonal steel
- Lever cutter at one end, bent head with nail claw at the other end

Order no.	Length mm	Weight g
210330	400	900
280090	600	1200
280092	800	1800



Dönges sheet metal ripper

Classic tool, tried and tested many times in the field. With hardened impact tip and sheet metal cutter. Tubular handle with red insulating plastic hand guard.

Order no.	Length mm	Weight g
211510	650	1100



Dönges Prying tool

Practical, cost-efficient hooligan tool with many standard functions.

Features:

- Painted red
- With impact tip and cutter for ripping open sheet metal and levering and breaking tool

Order no.	Length mm	Weight g
211515	620	3100

PRT kit (Percussive Rescue Tool)

The full Paratech tool kit for initial responses. The sturdy nylon bag contains all that is needed for emergency services to obtain access, even in difficult situations.

The "sledge hammer" is integrated in the handle of the PRT kit. The heavy handle is pulled out and then slammed back onto the tube. The considerably energy that is released is transmitted to the different tool attachments. The handle can also be locked in the extended position and then used as a lever for the different tool attachments.

The tool can even be used to chisel concrete. The top quality attachments are specially hardened, and have an extremely long service life. High quality steel and aluminium alloys give the tool its tremendous sturdiness.

Scope of delivery:

Handle with pull-out beater arm/levering arm (PRT hand ram), pointed chisel, lever claw, metal cutting claw, flat chisel, spade chisel and nylon bag

Order no.	Item	Length mm	Weight g
211542	PRT-KIT (complete)	686	13200
211544	PRT hand pile driver	648	4500
211546	Levering claw	216	1700
211548	Metal cutting claw	216	1400
211550	Flat chisel	368	1500
211552	Pointed chisel	368	1500
211554	Spade chisel	368	1700
211556	Nylon bag	686	700



PRT kit opened up



Dönges one-man door ram

Simple but extremely effective tool for opening doors. Used by the German KSK. Because of the heavy intrinsic weight and the high level of kinetic energy when the ram is swung, a considerable amount of energy is released when the ram hits the door in the vicinity of the lock that even heavy doors and locks cannot withstand.

The large head reduces the risk of smashing in the door leaf.

- Painted tactical black
- Hand protection ring for front hand



made in Germany

exclusive DÖNGES

Order no.	Length mm	Weight kg
211512	600	16

Set of breaking tools DIN 14901

In carry bag (dimensions 710 x 160 mm), made from high-quality, black full-grain leather with adjustable strap.

Each component is secured with loops. The composition is compliant with DIN 14901, which has now expired.

Contents:

- 1 x Door opener
- 1 x Tambour shutter opener
- 1 x Engineer's hammer 300 g
- 1 x Slotted screwdriver 5.5 x 200 mm
- 1 x Punch 2 mm
- 1 x Punch 8 mm
- 1 x Pin punch 2 mm
- 2 x Sets of steel picks (type K and O)



made in Germany

exclusive DÖNGES

Order no.	Item	Weight g
211310	Set of breaking tools, complete	7100
211312	Door opener	3800
211313	Tambour shutter opener	600
280502	Engineer's hammer 300 g	380
211318	Screwdrivers	100
280418	Punch 2 mm	100
280419	Punch 8 mm	100
280424	Pin punch 2	65
211326	Set of picks K	300
211328	Set of picks O	300

Pick sets (lock picks)

Drop forged picks.

- Type K - 12 x K1-K12 for Chubb mortise locks 18 mm long with 10 mm bit
- Type O - 15 x O1-O15 for single tumbler locks

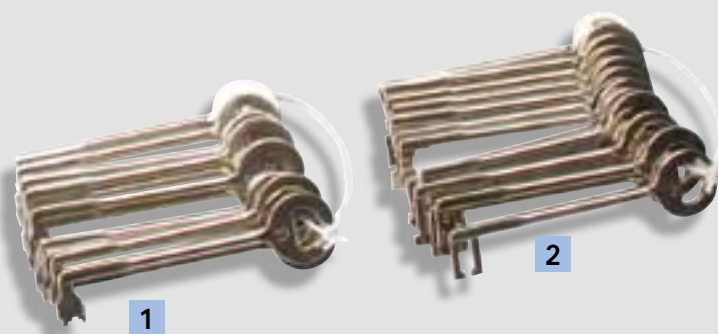

Order no.	Model	Weight g
1 211326	K	300
2 211328	O	300

Dönges lock picking tools Original "Glocke"

The lock puller is becoming increasingly popular in the fire brigade and rescue service area as a tool for opening doors.

This is because it is safe and easy to use: the pulling force is applied to the pulling screw **axially**. This reduces the risk of breaking off considerably. Also, there is only one screw to tighten. Troublesome switching between two lifting screws is not required.

The original Glocke made in Germany is extremely robust. A quality tool for continuous heavy use.

Everything that you need for quick, problem-free and tidy pulling of the lock cylinder is accommodated in a sturdy case (dimensions 380 x 290 x 100) with foam rubber insert made from industrial Plastazote:

Contents:

- 1 x Pulling device, original "Glocke"
- 2 x Core pulling plates for round and profile cylinders
- 1 Can WD-40 cutting oil 200 ml
- 1 Bott. Graphite antiseizing agent for pulling screws
- 10 x Pulling screws, original Zieh-Fix® "Standard"
- 10 x Pulling screws, original Zieh-Fix® "Extra"
- 10 x Pulling screws, original Zieh-Fix® "Super"
- 1 x Proxxon-Speeder ratchet W/F 17 x 19
- 1 x Bit holder with T-handle
- 1 x Bit set in box 10 pcs.
- 3 x Torx bits TX-20 for pulling screws
- 1 x Pointed pliers
- 1 x Metal profile cylinder closer
- 1 x Operating instructions

Order no.	Item	Weight g
216000	Dönges toolcase, complete	3300
211491	Pulling device, original "Glocke"	1160
211416	Core pulling plate for profile cylinder Ø 14.7 mm	120
211418	Core pulling plate for round cylinder Ø 16.8 mm	120
211419	WD-40 cutting and sliding oil	240
211422	Graphite antiseizing agent for pulling screws	60
211470	Pulling screws "Standard", pack of 10	40
211472	Pulling screws "Extra", pack of 10	40
211474	Pulling screws "Super", pack of 10	60
211476	Proxxon Speeder ratchet W/F 17 x 19	260
211478	Bit holder with T-handle	100
211480	Bit set, 10-piece	120
211421	Torx bit TX-20	10
211485	Pointed pliers, straight	200
212262	Bitting gauge	100



made
in
Germany

DÖNGES
exclusive



Zieh-Fix® toolcase

For quick and easy opening of almost any safety locking system, without damaging doors and hinges.

Contents:

- 1 x Zieh-Fix® tool, order no. 1002
- 2 x Core pulling plate, order nos. 1003 and 1004
- 1 x Special cutting and sliding spray, order no. 1061
- 1 x Graphite sliding agent, order no. 1062
- 1 x T-spanner wrench size 17 order no. 1071
- 1 x Bit holder with T-handle, order no. 0810
- 1 x Bit set, order no. 1077
- 1 x Pointed pliers, straight, order no. 1072
- 1 x Profile cylinder closer, order no. 1077
- 50 x Special pulling screws STANDARD, order no. 1201
- 50 x Special pulling screws EXTRA, order no. 1202
- 50 x Special pulling screws SUPER, order no. 1203

Order no.	Item	Weight g
211410	Zieh-Fix® toolcase	3700
211414	Zieh-Fix® device	500
211416	Core pulling plate for profile cylinder Ø 14.7 mm	120
211418	Core pulling plate for round cylinder Ø 16.8 mm	120
211419	WD-40 cutting and sliding oil	240
211422	Graphite antiseizing agent for pulling screws	20
211426	T-spanner W/F 17 mm	140
217405	Bit holder with T-handle	85
211475	Bit set	136



made
in
Germany

Order no.	Item	Weight g
211428	Pointed pliers, straight	200
211436	Profile cylinder closer	20
211440	Special pulling screws "Standard" (pack of 50)	160
211442	Special pulling screws "Extra" (pack of 50)	180
211444	Special pulling screws "Super" (pack of 50)	220

Pulling device, "Glocke"

The lock puller is becoming increasingly popular in the fire brigade and rescue service area as a tool for opening doors. This is because it is safe and easy to use: the pulling force is applied to the pulling screw **axially**. This reduces the risk of breaking off considerably. Also, there is only one screw to tighten. Troublesome switching between two lifting screws is not required. The original Glocke made in Germany is extremely robust. A quality tool for continuous heavy use.

Scope of delivery:

"Glocke" pulling device, core pulling plates for round cylinder and profile cylinder

Order no.	Weight g
211491	1160



made
in
Germany

Clamping device

Small, useful tool for securely screwing in pulling screws. The device can be used with a bit holder or a screwdriver.

- No pre-drilling required
- Robust design
- Replaceable 1/4" bit
- Suitable for all pulling screws

Scope of delivery:

Holder incl. Torx bit T20

Order no.	Weight g
211493	80



made
in
Germany

DOENGES
exclusive

Lock picking tools DIN 14800-SWK

In acc. with DIN 14800-12: 2004.

In Dönges Firebox® made by Zarges in acc. with DIN 14880-4-LM (400 x 300 x 150 mm) with aluminium dividers and labelling "Sperrwerkzeug" with individual lettering on request.

Contents:

- 1 x Bit holder with T-handle 1/4"
- 1 x bits, 10 pcs.
- 1 x screwdriver insert (bit) 1/4" TX-20
- 30 x Pulling screws 4.8 mm (Super)
- 1 x Clamping device for pulling screws
- 1 x Bottle Cutting and sliding oil
- 1 x Original lock puller
- 1 x Core pulling plate for round cylinders
- 1 x Core pulling plate for profile cylinders
- 1 x Proxxon-Speeder ratchet W/F 17 x 19
- 1 x Metal profile cylinder closer
- 1 x Spare lock 40/50
- 1 x Hinge lifter
- 1 x Door latch tool
- 1 x Door latch knives, 8, 9 and 10 mm
- 1 x Latch wire for doors with double rebate
- 1 x Door latch spiral openers
- 1 x Tilting window openers

Order no.	Item	Weight g
217460	Lock picking tool box, complete	8060
214085	Box DIN 14880-4-LM-12 empty	3800
217465	Set of lock picking tools (excluding case)	4260
211478	Bit holder with T-handle	100
211480	Bit set, 10-piece	120
211421	Torx bit TX-20	10
211470	Pulling screws "Standard", pack of 10	40
211472	Pulling screws "Extra", pack of 10	40
211474	Pulling screws "Super", pack of 10	60
211493	Clamping device for pulling screws	80
211419	WD-40 cutting and sliding oil	240
211491	Pulling device, original "Glocke"	1160
211476	Proxxon Speeder ratchet W/F 17 x 19	260
212262	Bitting gauge	100
211477	Spare cylinder	160
211495	Hinge lifter	1360
211437	Door latch tool	40
211433	Door latch knife 8 mm	40
211434	Door latch knife 9 mm	40
211435	Door latch knife 10 mm	40
217452	Latch wire for doors with double rebate	10
211429	Door latch spiral opener kit	120
211497	Tilting window openers	160

Individual lettering
on request.



made
in
Germany

DÖNGES
exclusive

Zieh-Fix® opening system "112"

We have put this tool selection together for special rescue organisation requirements. An aluminium case from the Rimowa® product range provides the equipment with optimum protection because of its sandwich structure consisting of aluminium, wood, polystyrene and plastic tray, and its reinforced corners and edges.

The waterproofing system of the case protects the equipment from water, moisture and dust. The tray-like special insert is so firmly closed by a sealing plate in the lid that the interior is hermetically sealed.



The most important tools and aids for emergency opening in houses and apartments are arranged in a hard-wearing foam rubber case inserted on two layers, of which the top layer can be quickly and easily removed from the case.

The set includes tools for opening closed doors via the door latch or the hinge, sets of picks for single tumbler and Chubb locking systems, pulling tools and hooligan tools for tearing off and core pulling of clock cylinders and a cutter for also opening high-quality locking systems.

The set also includes a hand pick set and a Zieh-Fix® electric pick in order to use non-destructive methods. We have also thought about tilting windows; the tilting window opener makes it possible to open these windows via the window handle.

Contents:

- 1 x Rocko Vario extension
- 1 x Bit holder with T-handle for 1/4" bits
- 1 x ZIEH-FIX video®
- 1 x ZIEH-FIX® Premium
- 1 x ZIEH-FIX® PStandard
- 1 x ZIEH-FIX® Glocke
- 1 x RA.PROX Proxxon Speeder ratchet
- 1 x Cutting and sliding spray
- 1 x Metal profile cylinder closer, long
- 1 x Metal profile cylinder closer, short
- 1 x T-spanner (nut) W/F 17 short
- 1 x Pointed pliers, straight
- 1 x Screwdriver, 1.2 mm x 8 mm x 150 mm
- 1 x Door latch opening tool
- 1 x Door latch opening needle set
- 1 x ZIEH-FIX® door latch hinge lifter
- 1 x ZIEH-FIX® door latch square, 8 mm for 72 distance
- 1 x ZIEH-FIX® door latch square, 9 mm for FH doors
- 2 x ZIEH-FIX® door latch square, 10 mm for 92 distance
- 1 x Door latch opening card set
- 1 x ZIEH-FIX® pulling screw Standard, 100 pcs., Ø 3.9 mm
- 1 x ZIEH-FIX® pulling screw Extra, 100 pcs., Ø 4.2 mm
- 1 x ZIEH-FIX® pulling screw Super, 100 pcs., Ø 4.8 mm
- 1 x ZIEH-FIX® pulling screw Special, 100 pcs., Ø 5.5 mm
- 1 x Bit set 1/4", 9 bits with quick-change holder
- 2 x Torx bit Tx20
- 1 x MAKITA straight grinder, mod. 906, 220 Volts
- 2 x Hard metal cutter Ø 6.0 mm, 60 mm length
- 1 x Aluminium cutter Ø 6.0 mm, 50 mm length, HSS
- 1 x Set of picks K 1-12 for Chubb mortise locks
- 1 x Set of picks O 1-15 for single tumbler and crew locker locks
- 1 x Extractor set series 2000
- 1 x Variable tension tool TNT-20
- 1 x Locking rotor accelerator Flipper
- 1 x Tilting window openers, complete
- 1 x ZIEH-FIX® electric pick incl. charger
- 1 x ZIEH-FIX® electric pick clamping tool kit
- 1 x ZIEH-FIX® pick needle set Novum
- 1 x Video on CD-ROM "ZIEH-FIX® electric pick"

Order no.

211460

Weight kg

29,6

Zieh-Fix® opening system "112-Akku"

This set is essentially the same as the Zieh-Fix® opening system "112", but contains a Milwaukee battery-powered straight grinder PSG 14.4 PP/1. This makes the case even more versatile and flexible to use.

Contents

- 1 x Rocko Vario adapter blade
- 1 x Bit holder with T-handle for 1/4" bits
- 1 x Video on CD-ROM "ZIEH-FIX® pulling devices"
- 1 x ZIEH-FIX®
- 1 x ZIEH-FIX® "Glocke"
- 1 x Proxxon Speeder ratchet W/F 17/19
- 1 x Separating and sliding spray, 100 ml
- 1 x Multifunction spanner
- 1 x Metal profile cylinder closer without square journal
- 1 x T-spanner (nut) W/F 17 short
- 1 x Pointed pliers, straight
- 1 x Screwdriver 1.2 x 8 x 150 mm
- 1 x Door latch opening tool
- 1 x Power Cracker "Master Professional"
- 1 x Door latch opening needle set
- 1 x ZIEH-FIX® door latch hinge lifter
- 1 x ZIEH-FIX® door latch square, 8 mm for 72 distance
- 1 x ZIEH-FIX® door latch square, 9 mm for FH doors
- 2 x ZIEH-FIX® door latch square, 10 mm for 92 distance
- 1 x door latch opening card set
- 2 x ZIEH-FIX® pulling screw "Standard", 50 pcs. , Ø 3.9 mm
- 2 x ZIEH-FIX® pulling screw "Extra", 50 pcs. , Ø 4.2 mm
- 2 x ZIEH-FIX® pulling screw "Super", 50 pcs. , Ø 4.8 mm
- 2 x ZIEH-FIX® pulling screw "Special", 50 pcs. , Ø 5.5 mm
- 1 x Bit set 1/4", 9 bits with quick-change holder
- 2 x Torx bit Tx20
- 1 x Screw-in tool, 1/4", with Torx bit T-20
- 1 x Accu-straight grinder Milwaukee, PSG 14.4 PP/1
- 2 x Hard metal cutter Ø 6.0 mm, 60 mm length
- 1 x Aluminium cutter Ø 6.0 mm, 50 mm length, HSS
- 1 x Set of picks K 1-12
- 1 x For Chubb mortise locks, pick set O 1-15 single tumbler and crew lockerlocks
- 1 x Extractor set 2000
- 1 x Variable tension tool TNT-20
- 1 x Locking rotor accelerator "Flipper"
- 1 x Tilting window openers, complete
- 1 x ZIEH-FIX® electric pick incl. charger
- 1 x ZIEH-FIX® electric pick clamping tool kit
- 1 x ZIEH-FIX® pick needle set "Novum"
- 1 x Video on CD-ROM "ZIEH-FIX® electric pick"



made
in
Germany



Order no.
211461

Weight kg
29,6

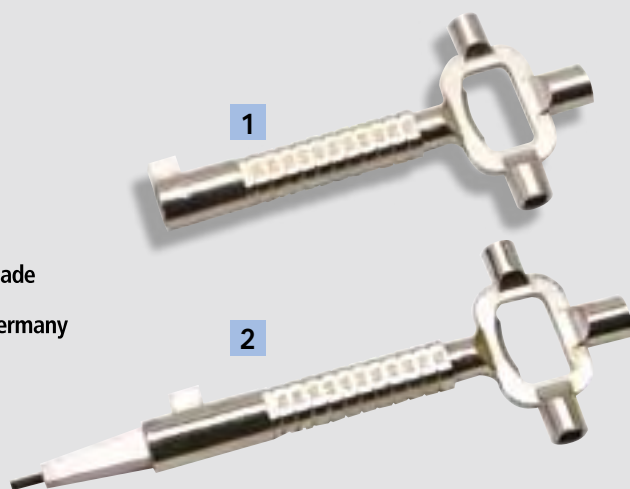

made in Germany

Bitting gauge

Made from mirror-finish, nickel plated annealed cast iron. For profile cylinder locks (17 mm Ø), with internal square insert 6, 7 and 8 mm and bottle opener. Scale for measuring profile cylinder lengths

Model 3679

Order no.	Length mm	Weight g
1 212262	143	100

Model 3678

also with square journal 6-10 mm and hardened 3 mm Allen key in the tip.

Order no.	Length mm	Weight g
2 212260	180	120



Multi-Function key

The new MFS multifunction spanner can be used for opening, closing, measuring, testing and installing. This all-rounder is made from nickel-plated zinc alloy and is used in many areas such as the fire brigade, THW, police, key services, security companies and chimney sweeps.

Features:

- External square 6 - 10 mm
- Internal triangle 8 and 9 mm
- Internal square 5, 7 and 8 mm
- Philips screws
- Slotted screws
- Magnetic bit and adapter holder
- Follower for locks with PZ holes
- Switch cabinet locking
- Daimler-Benz locking
- Heater ventilation locking
- Scale for measuring the required profile cylinder lengths



made in Germany

Order no.	Dimensions mm	Weight g
212264	122 x 64	150

Diagonal cutting lead sealing pliers

Lead sealing pliers made from stainless steel, for 8 mm lead seals. With integrated wire cutters for cutting the lead sealing wire. Makes it possible to seal equipment crates, cases containing hazardous materials, wall cabinets etc. The lead sealing pliers are supplied without a stamp. The stamps can also be engraved in accordance with customer requirements (please inquire).

Features:

- Chrome-plated version
- Integrated wire cutters
- For lead seals up to 8 mm in diameter

Order no.	Item	PU/pc.	Weight g
280206	Lead sealing pliers	1	160
280208	Stamp (two required)	1	2
280210	Lead seals 8 mm	ap. 850	1000
280212	Lead sealing wire 200 mm	ap. 1000	500

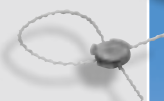

made
in
Germany

Combination pliers DIN 5244

Made from chrome vanadium steel, inductively annealed, chrome-plated head, handles with dual-component sleeves.

Order no.	Length mm	Weight g
218060	180	300
217235	200	400



exclusive **DÖNGES**

Nipper pliers DIN 5241

Painted black.

Order no.	Length mm	Weight g
211875	250	300



made
in
Germany

Parallel vice 'Matador'

Steel-forged, hardened vice with large anvil and adjustable guide. German brand name product, best workshop quality.

Order no.	Jaw width mm	Clamping width mm	Weight kg
280048	100	120	6,0
280049	120	150	10,0
280050	140	200	18,0
280051	160	225	25,0
280052	180	225	26,0

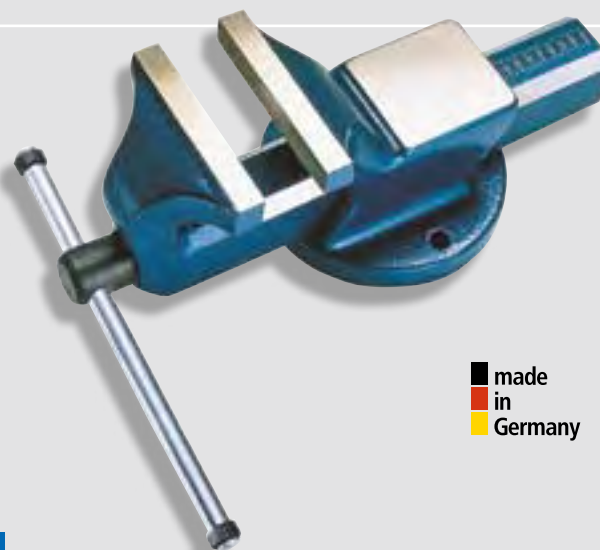

made
in
Germany

Slip joint pliers DIN 5231

Painted, with push-through, 7-way adjustable sliding joint. With anti-trapping protection.

Order no.	Length mm	Weight g
211848	180	200
211850	240	300
211852	400	400



Slip joint pliers, non-sparking

Made from copper beryllium, with sliding joint, fine sand-blasted finish, red hand protection grips. For use in potentially explosive areas.

Order no.	Length mm	Weight g
285010	250	300
285012	310	600

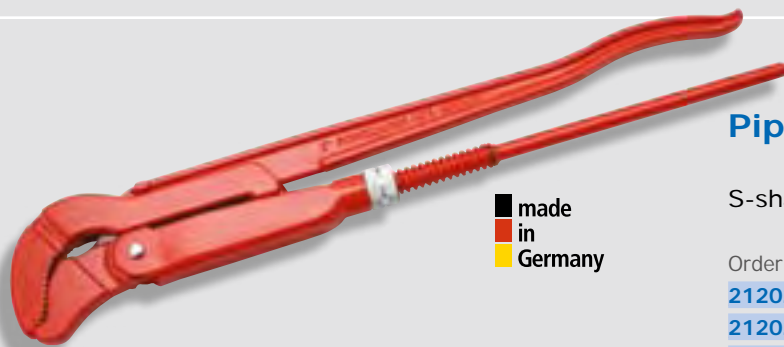

made
in
Germany

Pipe wrench

S-shape, painted red, industrial quality.

Order no.	Size	Jaw width mm	Weight g
212020	1"	3 - 25	600
212025	1½"	6 - 30	1700
212031	2"	6 - 50	2500



Pipe wrench, non-sparking

Swedish design, made from copper beryllium, fine sand-blasted finish.

For use in potentially explosive areas.

Order no.	Size	Jaw width mm	Weight g
285014	1"	3 - 25	1500
285016	1½"	6 - 30	1800
285018	2¼"	6 - 50	2400

Stillson pipe clamp, non-sparking

Made from special bronze with fine sandblasted surface. For use in potentially explosive areas.

Order no.	Length mm	Jaw width mm	Weight g
285020	460	50	2200

Bolt cutters

With powder-coated tubular steel handles and PVC grips.

Features of the professional version:

- High-performance cutter made from chromium alloyed steel, induction hardened
- Body made from forged steel
- Hardened screws for longer service life
- Extremely light handles made from steel tube
- Minimum force required during cutting



Order no.	Model	Length mm	Cutting capacity with 75 kp/mm ²	Weight g
212150	Professional	450	7	1400
1 212155	Professional	610	9	2500
212160	Professional	760	11	4300
212165	Import model	910	13	5100
212161	Professional	910	13	5100
212170	Professional	1050	15	8600

Bolt cutters with catch hook

With powder-coated tubular steel handles and PVC grips. The galvanised catch hook allows the material that is being cut to be threaded in, even if you are stood on a ladder or visibility is poor, for example.

Features:

- High-performance cutter made from chromium alloyed steel, induction hardened
- Body made from forged steel
- Hardened screws for longer service life
- Extremely light handles made from steel tube
- Minimum force required during cutting

Type A, with black plastic handles.

Order no.	Length mm	Cutting capacity with 75 kp/mm ²	Weight g
1 212110	650	9	2400
212125	955	13	5020

Type B, with up to 1000 V insulated handles and black plastic grips (ATTENTION: not VDE tested).

Order no.	Length mm	Cutting capacity with 75 kp/mm ²	Weight g
212115	650	9	2700
212130	955	13	5020

Model C, army version with Desmopan-insulated handles (sleeves are insulated up to 10,000 V).

Order no.	Length mm	Cutting capacity with 75 kp/mm ²	Weight g
2 212120	675	9	3000



1/4" socket set 33-piece

Universal standard set in steel plate box
All parts chrome plated matt made from CV steel 31 CrV 3.

- Hexagonal inserts with edge drive 4-14 mm
- Hexagonal socket inserts 3, 4, 5, 6, 8 mm
- Slotted inserts 4, 4.5, 5.5, 6.5 mm
- Cross-head inserts PH-1, -2, -3, -4; PZ-1, -2, -3
- Reversible lever ratchet
- Tee-bar
- T-handle
- 50 and 100 mm extensions
- Cardan joint

Order no.

216115

Weight g

1600

*exclusive* **DOENGES****3/8" socket set 15-piece**

Basic configuration in steel plate box, with the most important inserts and operating tools.
All parts chrome plated matt made from chromium vanadium steel 31 CrV 3.

- Hexagon inserts with edge drive 8, 10, 12, 13, 14, 15, 17, 19, 21, 22, 24 mm
- Reversible lever ratchet
- Extension 75 mm
- Extension 125 mm
- Cardan joint

Order no.

216008

Weight g

1600

exclusive **DOENGES****1/2" socket set 24-piece**

Basic configuration in steel plate box, with the most important inserts and operating tools.

All parts chrome plated matt made from CV steel 31 CrV 3.

- Hexagonal inserts with edge drive 10-32 mm
- Reversible lever ratchet
- Sliding handle
- 125 and 250 mm extensions
- Cardan joint

Order no.

216005

Weight g

5500

*exclusive* **DOENGES**

DIN spanner sets

Made from chromium vanadium steel.
Supplied with plastic holder.

Double-ended open-jawed spanner DIN 3110

- DIN 3110 double-ended open-jawed spanner, 8-piece, (6x7/8x9/10x11/12x13/14x15/16x17/18x19/20x22 mm)
- DIN 3110 double-ended open-jawed spanner, 12-piece, (6x7/8x9/10x11/12x13/14x15/16x17/18x19/20x22/21x23/24x27/25x28/30x32 mm)

Order no.	Pieces	W/F mm	Weight g
280220	8	6-22	800
280222	12	6-32	2200

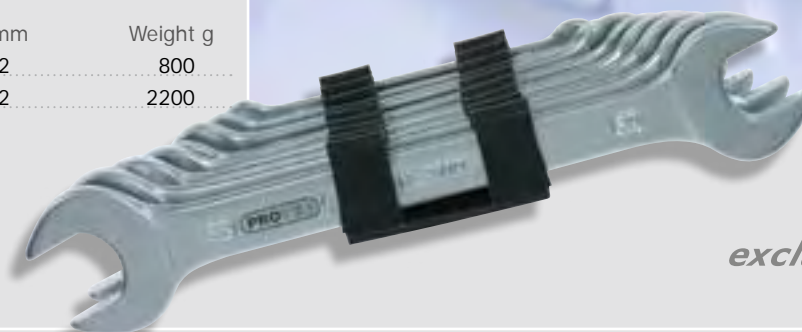

DÖNGES
exclusive

Double ended ring spanner DIN 838

- DIN 838 double ring spanner, 8-piece, (6x7/8x9/10x11/12x13/14x15/16x17/18x19/20x22 mm)
- DIN 838 double ring spanner, 12-piece, (6x7/8x9/10x11/12x13/14x15/16x17/18x19/20x22/21x23/24x27/25x28/30x32 mm)

Order no.	Pieces	W/F mm	Weight g
280224	8	6-22	1400
280226	12	6-32	3400

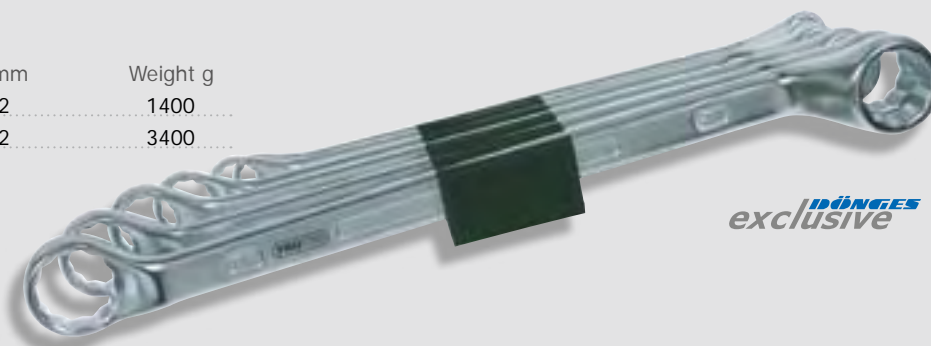

DÖNGES
exclusive

Combination ring and open-end spanner DIN 3113

- DIN 3113 Combination ring and open end spanner, 8-piece, (8/9/10/11/13/14/17/19 mm)
- DIN 3113 Combination ring and open end spanner, 12-piece, (6/7/8/9/10/11/12/13/14/17/19/22 mm)

Order no.	Pieces	W/F mm	Weight g
280228	8	8-19	500
280230	12	6-22	2000

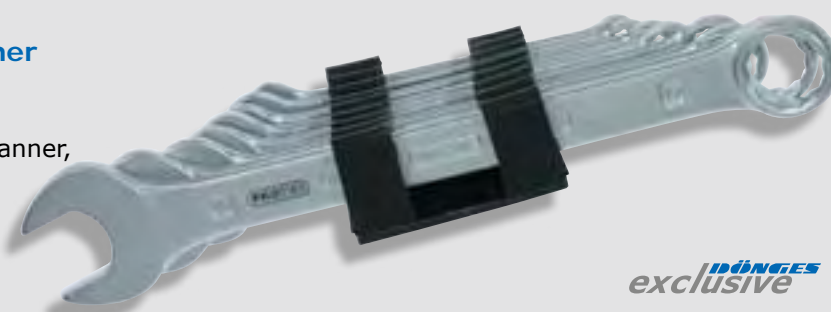

DÖNGES
exclusive



made
 in
 Germany

"Economy" Spanner for barrier posts

Cost-effective, simple bollard wrench made from galvanised tube material. With handle. Suitable for all barrier posts in acc. with DIN 3222.

Order no.	Length mm	Weight g
218070	240	160

Spanner for barrier posts

Bollard wrench made from annealed cast iron, specially for fire brigade and emergency vehicles. Suitable for all barrier posts in acc. with DIN 3222 and barriers.

Order no.	Length mm	Weight g
212270	300	400

Barrel spanner, non-sparking

Made from special bronze, fine sandblasted surface, for 22 barrel nuts. For use in potentially explosive areas.

Order no.	Length mm	Weight g
285022	380	1250



made
 in
 Germany

DOENGES
exclusive



Screwdriver DIN 5265

With black PP moulded handle, suspension hole and blade made from CV steel.

Order no.	Design	mm	mm	Weight g
212311	Slotted	4	100	40
212315	Slotted	5,5	125	60
212320	Slotted	8	175	140
212326	Slotted	10	200	160
211055	Phillips Size	1	80	40
211056	Phillips Size	2	100	90
211057	Phillips Size	3	150	140



made
in
Germany

DÖNGES
exclusive

Screwdriver, non-sparking

With orange cellulose acetate handle. Blade made from copper beryllium.
For use in potentially explosive areas.

Order no.	Design	mm	mm	Weight g
285030	Slotted	4,5	195	60
285032	Slotted	4,5	245	70
285034	Slotted	6	205	95
285036	Slotted	6	255	100
285038	Slotted	8	265	150
285040	Slotted	10	325	190
285042	Phillips Size	1	175	60
285044	Phillips Size	2	205	90
285046	Phillips Size	3	265	170
285048	Phillips Size	4	325	280



made
in
Germany

DÖNGES
exclusive



made
in
Germany

DÖNGES
exclusive

Dönges clip lifter

Special tool for undoing the inner panelling of vehicles of any type. The specially designed tip engages beneath the clips that are used to attach the panelling. The clips can then be easily removed by means of the levering effect. Indispensable during rescue operations involving vehicle accidents.

Features:

- Large, non-slip, dual-component moulded handle
- Reliable grip, even with gloves
- Blade made from sturdy CV steel

Order no.	Length mm	Weight g
217531	210	120

Metal bow saw DIN 6473A

With captive clamping rings, without saw blade.

Order no.	Item	Length mm	Weight g
211025	Metal bow saw	450	600
211030	Saw blade, 24 teeth	300	45

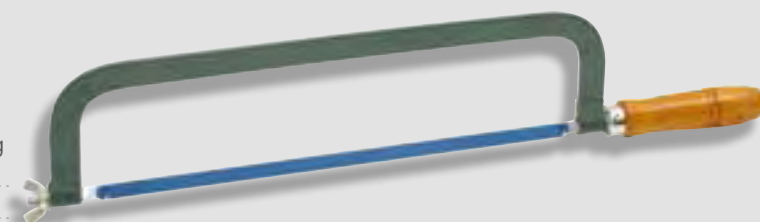

Tree saw

With sturdy oval bow, galvanised tensioner, quick-cutting saw blade, teeth crossed and sharpened.

Order no.	Item	Length mm	Weight g
280006	Tree saw	450	500
280007	Spare saw blade	450	50



Bow saw

With sturdy oval bow, galvanised tensioner, quick-cutting saw blade, teeth crossed and hardened.

Order no.	Item	Length mm	Weight g
280008	Bow saw	760	700
280009	Spare saw blade	760	70
280010	Bow saw	915	1100
280011	Spare saw blade	915	110



Cross-cut saw

With riveted eyes and two wooden handles.

Order no.	Blade length mm	Weight g
212460	1200	1300

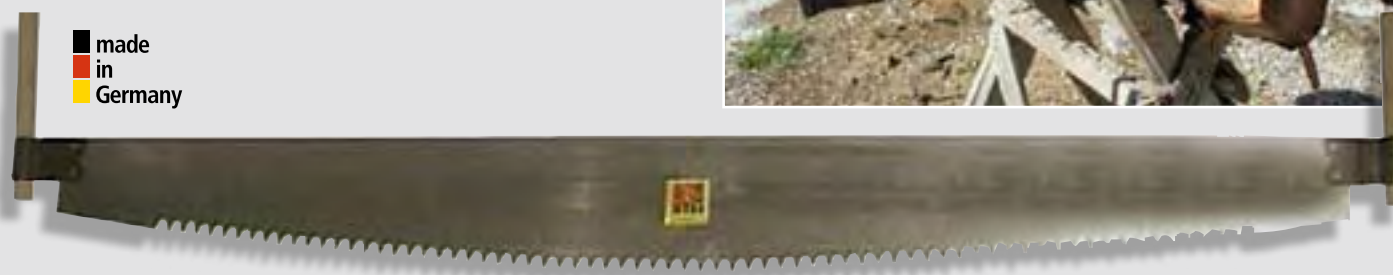

made
in
Germany

Piercing saw DIN 7258

Made from the best electrosteel, polished, crossed and sharpened, with varnished wooden handle.

Order no.	Blade length mm	Weight g
280038	350	160



made
in
Germany

Hand saw DIN 7244 (back saw)

Made from the best electrosteel, polished, crossed and sharpened, with varnished wooden handle.

Order no.	Blade length mm	Weight g
280005	400	400



made
in
Germany

Ceiling hook, lightweight (35 mm Ø)

With handle 35 mm Ø, hook part made from forged steel, galvanised hook and coupling pieces.

Type 1:

Ceiling hook, consisting of hook part and wooden handle 2.5 m.

Type 2:

Ceiling hook, two-piece, with two couplings, 2.5 m.

Type 3:

Ceiling hook, three-piece, with four couplings, 3.0 m.

Order no.	Model	Length m	Weight g
210410	1	2,5	2700
210420	2	2,5	3600
210430	3	3,0	4900
210422	Spare handle for 1-piece		1000
210424	Spare handles for 2-piece (2 pc.)		1000



made
in
Germany

DÖNGES
exclusive

C

V



made
in
Germany

DÖNGES
exclusive

DIN 14851 Ceiling hook (50 mm Ø)

With handle 50 mm Ø, hook part made from forged steel. Galvanised hook and coupling parts.

Type C:

Ceiling hook, consisting of hook part (DIN 14851-1), wooden handle 2.5 m and coupling part H (DIN 14851-2).

Type V:

Extension (DIN 14851-3), consisting of wooden handle 2.5 m and coupling part V.

Type A:

5 m long (DIN 14851-5), consisting of types C and V.

Order no.	Model	Length m	Weight g
210450	A (=C+V)	5,0	8300
210460	C	2,5	4300
210470	V	2,5	4000
210462	Spare handle for C		3000
210472	Spare handle for V		3000

Nupla fibre glass handle

Nupla fibre glass handles are characterised by their outstanding robustness and sturdiness. The extraordinary strength of the handles is achieved using a special manufacturing method in which the glass fibres are aligned in one direction before they are given their shape by means of heat and high pressure. At 70%, the proportion of glass fibre is greater than the amount used by any other fibre glass handle manufacturer.

This special sturdiness and the fact that the fibre glass handle has extremely good insulating properties against electricity and heat and cold is an extremely positive safety factor for the user.

Nupla handles are easy to recognise by the black "vein" on the yellow handle. Only these handles have the major benefits that have been mentioned.

Features:

- Extremely strong
- Proportion of glass fibre in handle >70%
- Extremely good insulation against voltage
- Extremely good insulation against heat and cold
- Long service life, no material ageing



With stable honeycomb structure



Combination option



1



2



Ceiling hooks with Nupla fibre glass handle

The specially shaped ceiling hooks with NUPLA handle are similar to the German ceiling hooks, but have significant benefits during use. They are considerably lighter yet sturdy and resistant to moisture and wetness, and also to temperature fluctuations. The NUPLA handle also insulates extremely well. These properties have made it a standard for the fire brigades in the USA. The ceiling hooks are available with a straight handle or a D-grip.

Features:

- Feather light but yet extremely stable
- Sturdy, forged hook parts
- Choice of two handle shapes
- Good electrical insulation
- Extremely good price/performance ratio

	Order no.	Handle shape	Length cm	Weight g
1	210441	Straight	183	2900
2	210442	D-grip	183	3600
	210444	Straight	244	3300
	210446	D-handle	244	4000
	210447	Straight	305	3700
	210449	D-grip	305	4400

Ripping hook with Nupla fibre glass handle

The specially shaped ripping hooks with NUPLA handle are perfect for ripping open the roof skin of flat roofs in the event of sulphur fires. The ripping hooks are extremely widespread in fire brigades in the USA. The advantages thereof are gaining an increasing amount of acceptance in other country as well. They are just as light and indestructible as the ceiling hooks with NUPLA handle, and are available with the same dimensions and the same handle shapes.

Features:

- Feather light but yet extremely stable
- Sturdy, forged hook parts
- Choice of two handle shapes
- Good electrical insulation
- Extremely good price/performance ratio

Order no.	Handle shape	Length cm	Weight g
1 210473	Straight	183	3600
2 210474	D-handle	183	4300
210475	Straight	244	4000
210476	D-handle	244	4700
210477	Straight	305	4400
210478	D-handle	305	5000

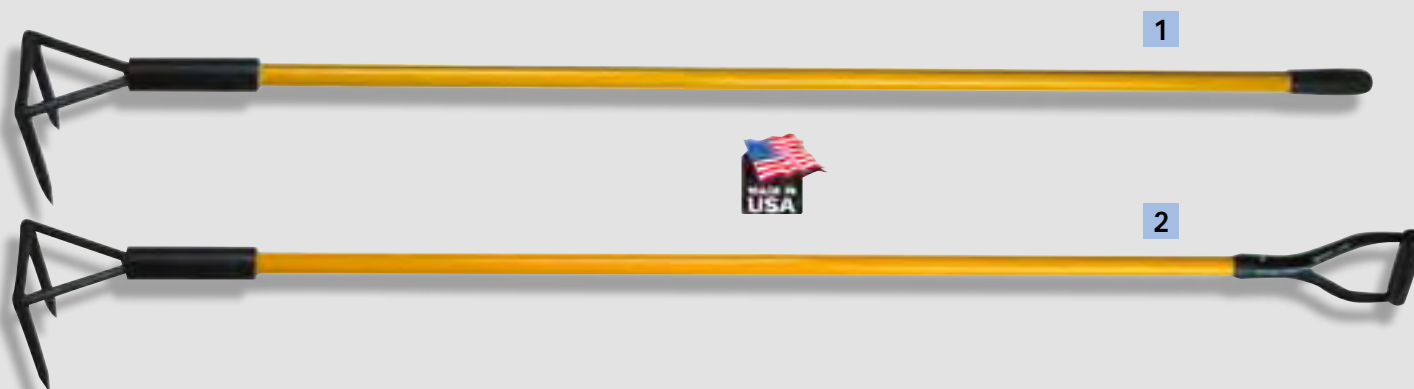

Nupla combination replacement system

This replacement system makes it possible to use different tools with a Nupla fibre glass handle. This makes the use of this extremely sturdy and robust tool handle even more attractive. Of course, just like the extension and the different tools, the replacement handle has all of the benefits of the special Nupla material.

A maximum of three parts can be combined.

The "roof kit" is a complete set, consisting of a ceiling hook part, rake hook part, D-grip handle and 120 cm extension.

Features:

- Quick tool changes
- Easier to use because of short handle
- Extremely versatile because of variable extension capability
- Two different tools can be used
- Sturdy D-grip for secure hold
- Extremely good price/performance ratio

Order no.	Name	Length cm	Weight g
1 210400	Ceiling hook part	90	1800
2 210402	Ripping hook part	90	2600
210404	Straight handle	90	1400
3 210406	D-grip handle	90	1700
4 210408	Extension	90	1200
210409	Extension	120	1500
210411	Roof kit 4-piece		7600



Axes with Nupla fibre glass handle

These axes, which are particularly widespread in the USA and other English-speaking countries, are popular because of their tremendous sturdiness. The NUPLA handle is almost unbreakable because of its special design and high proportion of fibre glass.

Whereas the "American design" fire brigade axe is used in a similar way to the German fire brigade axe, the Pulaski axe is mainly used for bush and forest fires. The blade of the axe is used to cut off hanging branches or

fell small trees, and the hoe can be used to create a fire break in any kind of ground.

Features:

- Handle is almost indestructible
- High quality, forged axe head
- Good electrical insulation
- Extremely good price/performance ratio

	Order no.	Head design	Length cm	Weight g
1	210480	American design	90	2800
2	210481	Pulaski	90	2900
3	201007	FB axe similar to DIN	90	2400



Bolt cutters with Nupla fibre glass grips

Extremely high quality and extremely sturdy screw cutters with NUPLA fibre glass grips. Extremely strong and insulating. Suitable for any type of use. Particularly cutting through hard material such as lock shackles is no problem for these screw cutters.

Features:

- Almost indestructible
- High quality forged blades for the hardest of materials
- Good electrical insulation
- Extremely good price/performance ratio

Order no.	for wire Ø	Length cm	Weight g
210482	8	450	1700
210483	11	600	2700
210484	13	760	4500
210485	16	910	6300



Fire rakes with Nupla fibre glass handle

Extremely sturdy special rake for making fire breaks in the forest floor. The sharp teeth of the rake dig effortlessly into dry and hard ground.

Features:

- Feather light but yet extremely stable
- Sturdy, ground teeth
- Extremely good price/performance ratio

Order no.	Length cm	Weight g
210486	152	2300

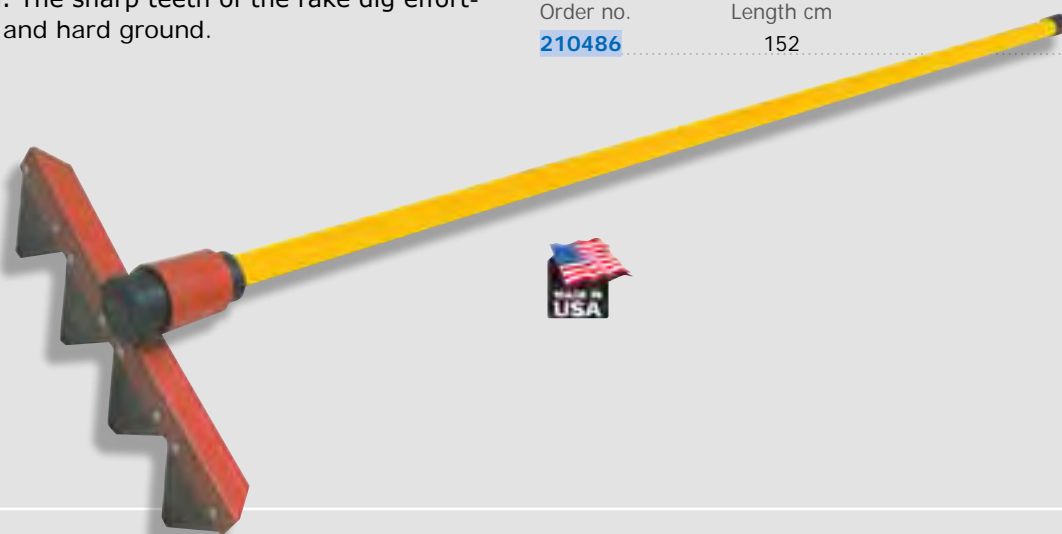

"McLeod-Tool" with Nupla fibre glass handle

Sturdy special tool for making fire breaks in the forest floor. The sharp hoe at one side cuts through roots, and the rake will dig effortlessly into dry and hard ground.

Features:

- Feather light but yet extremely stable
- Hoe at one side, rake at the other
- Extremely good price/performance ratio

Order no.	Length cm	Weight g
210487	122	6800

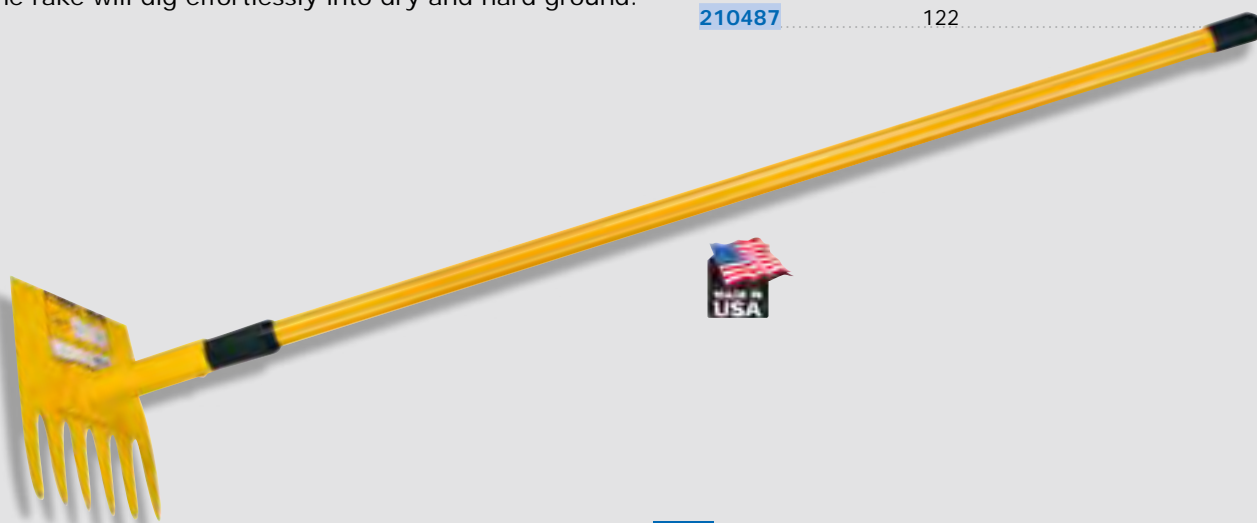

Sand shovel, Bavarian design

With ash handle, strong forged version, pointed design, varnished. Particularly suitable for fighting forest fires (making fire breaks), chopping off branches etc.

Order no.	Length mm	Weight g
1 210515	1600	2300

Pioneer shovel

Extremely short (960 mm) and handy ballast shovel, powder coated in black, blade size 300 x 240 mm, with CY handle.

Order no.	Item	Length mm	Weight g
2 210530	Shovel	960	2100
210532	Replacement CY handle		600

"Frankfurt" shovel DIN 20121

Powder coated in black, blade size 300 x 270 mm (size 5), with long beech handle.

Order no.	Item	Length mm	Weight g
3 210510	Shovel	1300	2000
210512	Spare handle		900

"Holstein" sand shovel DIN 20120

Powder coated in black, blade size 270 x 250 mm (size 2), with long beech handle.

Order no.	Item	Length mm	Weight g
4 210520	Shovel	1300	1800
210512	Spare handle		900

Square point shovel, lightweight material

Without protective steel edge, with 6 rivets in socket. Blade size 380 x 380 mm (size 9).

ATTENTION: Handle must be ordered separately!

Order no.	Item	Length mm	Weight g
5 210511	Shovel	1300	1100
210512	Spare handle		900



Square point shovel, non-sparking

Fine sandblasted finish, blade size 220 x 310 mm, with ash handle. Two handle shapes are available. For use in potentially explosive areas.

Order no.	Handle	Length mm	Weight g
285070	Long handle	1300	2000
285072	D-grip handle	980	2200

PP shovels

These corrosion-resistant shovels made from polypropylene (PP) are characterised by their light weight and their good resistivity. The surface is non-stick and completely corrosion resistant. The material is UV stabilised and unbreakable.

These shovels are ideal for dealing with aggressive materials such as road salt and oil binding materials. They are also suitable for use in potentially explosive areas.

Order no.	Size mm	Length mm	Grip	Weight g
210522	315 x 250	980	D-grip	1100
210525	350 x 260	1050	D-grip	1400



Fire brigade spade DIN 20127

Powder coated in black, blade size 185 x 280 mm, with short ash handle. Two handle designs are available.

Order no.	Handle	Length mm	Weight g
210540	With CY-handle	1050	2200
210542	Replacement CY handle		700
210550	With T-handle	1050	2100
210552	Replacement T handle		600

Spade, non-sparking

Similar to DIN 20127, fine sandblasted finish, blade size 185 x 280 mm, with ash handle. Two handle designs are available.

For use in potentially explosive areas.

Order no.	Handle	Length mm	Weight g
280574	With T-handle	1160	2600
280576	With D-handle	1200	3000

Folding spade

Varnished in olive green, all metal, 240 mm in length when folded, blade size 210 x 155 mm.

Order no.	Model	Weight g
210560	Original german army version	1100
1 210565	Import version	1100



Railroad pick DIN 20109

Varnished in black, with oval eye and ash handle
950 mm long.

Order no.	Item	Size kg	Weight g
210610	Pickaxe	1,5	2300
210611	Spare handle	1,5	700
210630	Pickaxe	3,5	4300
210631	Spare handle	3,5	800



Railroad pick, non-sparking

Similar to DIN 20109, fine sandblasted finish, with oval eye and 950 mm ash handle.
For use in potentially explosive areas.

Order no.	Item	Size kg	Weight g
285068	Pickaxe	1,5	2200
210611	Spare handle	1,5	700
285069	Pickaxe	3,0	4800
210631	Spare handle	3,0	800



Dung hoe

Varnished in black, with 4 prongs, with long beech handle, with handle socket.

Order no.	Item	Length mm	Weight g
210661	Hoe	1350	1400
210662	Spare handle		900

Pitchfork

Varnished in black, with 4 prongs, with long, curved beech handle, with handle socket.

Order no.	Item	Length mm	Weight g
210651	Fork	1350	1300
210652	Spare handle		900



Ashlar fork

With nine prongs, 350 mm long, with long beech handle, with handle socket.

Order no.	Item	Length mm	Weight g
210670	Fork	1350	2800
210512	Spare handle		900

Piassava broom head

Beechwood road sweeping broom with Piassava bristles and metal threaded insert for attaching handle (screwed in).

ATTENTION: Handle must be ordered separately !

Order no.	Item	Weight g
210712	Broom 320 mm	600
210714	Broom 400 mm	800
210720	Wooden handle with metal thread	400



Elaston broom head

Beechwood road sweeping broom with red Elaston bristles and metal threaded insert for attaching handle (screwed in).

ATTENTION: Handle must be ordered separately !

Order no.	Item	Weight g
210716	Broom 400 mm	800
210720	Wooden handle with metal thread	400

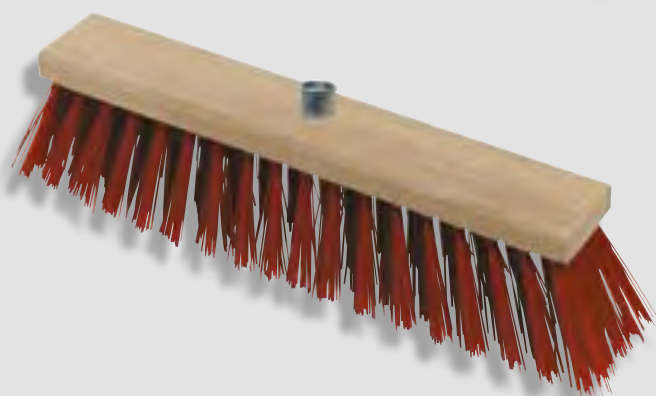

Rubber squeegee, metal

Made from metal with quick release mechanism, with double synthetic cellular rubber strip.

ATTENTION: Handle must be ordered separately !

Order no.	Item	Weight g
210730	Squeegee 560 mm	300
210732	Wooden handle 1400 mm	300

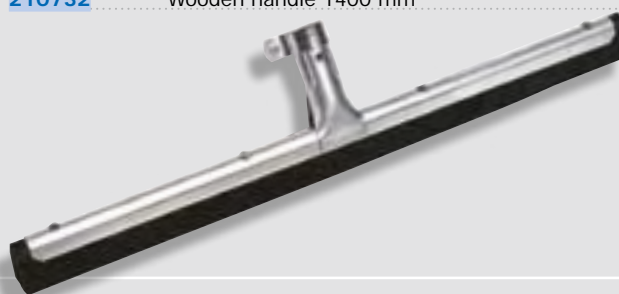

Rubber squeegee, wood

Made from wood, narrow version, with double synthetic cellular rubber strip.

For use in potentially explosive areas.

ATTENTION: Handle must be ordered separately !

Order no.	Item	Weight g
210735	Squeegee 600 mm	300
210732	Wooden handle 1400 mm	300



fix-o-mat-broom for indoors

Fix-o-mat brooms with micro structure bristles contain plastic structure particles made from gently cleaning plastic on the inside and the outside. The bristles get right down to the dirt and remove it more thoroughly than conventional brushes, from any floor and even textile structures, tile grout, carpets etc.

The broom head is made of plastic and comes with the well-tried fix-o-mat handle connection. This allows fix-o-mat system handles to be securely attached without problems.

Features:

- Plastic broom head
- fix-o-mat handle connection

Order no.	Bristle composition	Width mm	Weight g
1 210672	Flexon mixture/MicroStructure	280	290
2 210674	Natural hair/MicroStructure	280	280
210676	Natural hair/MicroStructure	400	435
3 210678	Natural hair/MicroStructure	600	670
4 210680	Artificial bristles/Arenga	280	355



made in Germany



made in Germany

fix-o-mat broom for outdoors

These micro-structure bristles provide the best results on any surface, even outdoors. Different widths and different bristle mixtures for different usage areas.

Features:

- Plastic broom head
- fix-o-mat handle connection
- Road sweeping broom (400 mm width) with scrubbing edge

Order no.	Bristle composition	Width mm	Weight g
1 210682	Artificial bristles/MicroStructure		
	with scrubbing edge	400	473
210684	Plastic bristles/MicroStructure	400	475
2 210686	Plastic bristles/MicroStructure	600	705
3 210688	Coconut fibre	400	390

fix-o-mat water squeegee

Fix-o-mat water squeegees meet the most demanding of requirements. The different versions cover all usage areas. The robust version and the high quality materials are also resistant to aggressive media and ensure that the tool has a long service life.

Plastic unit

Order no.	Version	Width mm	Weight g
1 210690	Foam rubber double strip with brush	430	210
210692	Foam rubber double strip without brush	440	180

Metal unit, plastic coated

Order no.	Version	Width mm	Weight g
2 210694	Foam rubber double strip	580	325

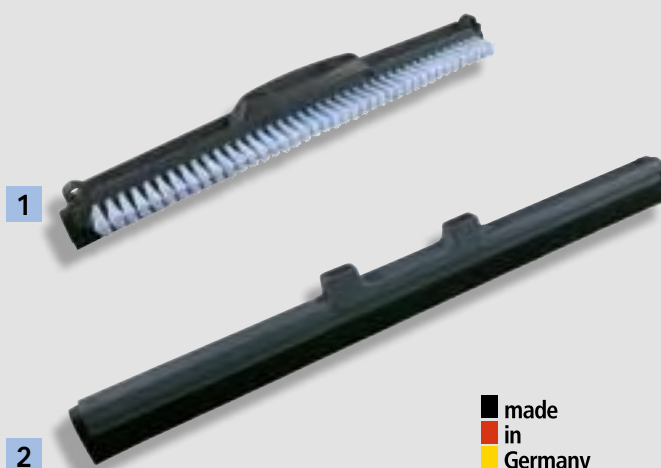

made
in
Germany

fix-o-mat system handles

Fix-o-mat system handles can be used in conjunction with all fix-o-mat attachments such as brooms, water squeegees etc. The handle is simply inserted into the body of the tool together with the special holder. Then simply clamp using the lever, and the connection is extremely secure.

The different handle variants provide the correct characteristics for any purpose of use.

Metal, rigid, extra sturdy

Order no.	Version	Length cm	Weight g
1 210700	Plastic coated	140	617
2 210702	Galvanised/chromatised	140	604

Metal, telescopic

Order no.	Version	Length cm	Weight g
3 210704	Anthracite/grey, varnished	130-223	688
4 210706	Plastic coated	92-157	384



made
in
Germany

Window wiper

Handy, small window wiper, suitable for drying vehicle windows prior to masking with film. Plastic handle with aluminium bar and special rubber strip.

Order no.	Width mm	Weight g
210966	290	110



made
in
Germany

Stackable transport boxes

These stackable transport boxes made from polypropylene are suitable for storing many items of equipment, both on the vehicle and in the equipment house.

The box sizes are tailored to the Euro palette size of 1200 x 800 mm. This also makes it easier to transport greater quantities of the boxes. As well as suitable lids (for snapping on or securing with clips) and covers, other useful accessories are available. The boxes can be equipped with case carrying handles in the factory, or the handles can be retrofitted. The handle holes can also be closed off with optional recessed grips. Label clips and label pockets in A6 format are also available. Available in red or grey, other colours on request.

Features:

- Compliant with the foodstuffs act
- Many different versions available
- The boxes can be securely closed using covers and other accessories

External dimensions: 400 x 300 mm
Internal dimensions: 356 x 255 mm

Order no.	External height mm	Internal height mm	Colour	Weight g
281050	120	110	red	600
281051	120	110	grey	600
281052	145	133	red	690
281053	145	133	grey	690
281054	175	165	red	780
281055	175	165	grey	780
281056	210	200	red	885
281057	210	200	grey	885
281058	270	255	red	970
281059	270	255	grey	970
281060	320	305	red	1340
281061	320	305	grey	1340



2



1



3

4

External dimensions: 600 x 400 mm
Internal dimensions: 551 x 352 mm

Order no.	External height mm	Internal height mm	Colour	Weight g
281062	120	110	red	1340
281063	120	110	grey	1340
281064	145	133	red	1330
281065	145	133	grey	1330
281066	175	165	red	1610
281067	175	165	grey	1610
281068	210	200	red	1660
281069	210	200	grey	1660
281070	270	255	red	1970
281071	270	255	grey	1970
281672	320	305	red	2500
281673	320	305	grey	2500



made
in
Germany

External dimensions: 800 x 600 mm
Internal dimensions: 750 x 545 mm

Order no.	External height mm	Internal height mm	Colour	Weight g
281674	210	200	red	3600
281675	210	200	grey	3600



Accessories:

Order no.	Item	Dimensions	Weight g
281678	Sealing cover	400 x 300 mm	370
3 281679	Sealing cover	600 x 400 mm	750
281680	Lid	400 x 300 mm	370
281681	Lid	600 x 400 mm	750
1 281682	Label clip	25 pcs.	250
2 281683	A6 label pocket	10 pcs.	40
4 281684	Recessed handle	10 pairs	600

Stackable transport cases

These practical and cost-effective stackable transport cases are based on the stackable transport boxes. They are already pre-assembled and have a locking lid, recessed handles and a case handle. These transport cases are available in widths starting at 400 mm.



Features:

- Compliant with the foodstuffs act
- Box size tailored to Euro palette size
- Lockable
- Easy to carry using case handle

External dimensions: 600 x 400 mm
Internal dimensions: 551 x 352 mm

Order no.	External height mm	Internal height mm	Colour	Weight g
281700	120	110	red	2210
281701	120	110	grey	2210
281702	145	133	red	2220
281703	145	133	grey	2220
281704	175	165	red	2490
281705	175	165	grey	2490
281706	210	200	red	2540
281707	210	200	grey	2540
281708	270	255	red	2850
281709	270	255	grey	2850
281710	320	305	red	3380
281711	320	305	grey	3380



made
in
Germany





Watertight DryBox

These extremely robust boxes with surrounding O-ring seal will reliably protect your equipment from water & dust. Manufactured from tough ABS, unbreakable in fall of up to 2 m onto concrete. An optional pluck foam inlay provides the equipment with reliable protection.

Features:

- The pluck foam can be adjusted in a suitable yourself
- ABS snap locks
- Stackable
- Hinge across the entire width

1 DryBox 309

External dimensions: 239 x 183 x 89 mm

Internal dimensions: 216 x 152 x 76 mm

Order no.	Box	Colour	Weight g
219798	With pluck foam	yellow	600
219800	With pluck foam	black	600

2 DryBox 409

External dimensions: 239 x 183 x 104 mm

Internal dimensions: 216 x 152 x 94 mm

Order no.	Box	Colour	Weight g
219802	With pluck foam	black	670

3 DryBox 609

External dimensions: 239 x 183 x 157 mm

Internal dimensions: 216 x 152 x 145 mm

Order no.	Box	Colour	Weight g
219804	Empty	black	850
219806	With pluck foam	black	850

Available with customised foam inlay on request



Watertight UltraBox

The ideal box for reliably protecting your equipment from water and dust. All UK Ultraboxes are super-sturdy and made dust-tight and watertight using an O-ring. The automatic pressure equalisation valve ensures that the box is easy to open, even after drastic pressure and temperature changes.

Features:

- Watertight up to 10 meters
- Two different lids are available: transparent, so that the contents can be recognised immediately, and opaque in order to protect parts from light, for example
- Made from extremely tough ABS, LEXAN, polyurethane & stainless steel
- A nylon bag is optionally available for the lid that can be used to hold even extremely small parts.
- Stackable
- Hand strap included



1 UltraBox 206

External dimensions: 170 x 119 x 58 mm
Internal dimensions: 140 x 90 x 50 mm

Order no.	Item	Colour	Weight g
219700	Empty	yellow	200
219702	Empty	black	200
219704	With rubber padding	yellow	220
219706	With rubber padding	black	220
219708	Transparent lid empty	yellow	200
219710	Transparent lid empty	black	200
219712	Transparent lid with pocket and rubber padding	yellow	240
219714	Transparent lid with pocket and rubber padding	black	240

2 UltraBox 406

External dimensions: 170 x 119 x 98 mm
Internal dimensions: 140 x 90 x 90 mm

Order no.	Item	Colour	Weight g
A 219716	Empty	yellow	200
B 219718	Empty	black	200
219720	With rubber padding	yellow	220
219722	With rubber padding	black	220
219724	Transparent lid, empty	yellow	200
219726	Transparent lid, empty	black	200
219728	Transparent lid with pocket and rubber padding	yellow	240
219730	Transparent lid with pocket and rubber padding	black	240



3 UltraBox 207

External dimensions: 200 x 98 x 61 mm
Internal dimensions: 170 x 70 x 55 mm

Order no.	Item	Colour	Weight g
219732	Empty	yellow	200
219734	Empty	black	200
219736	With rubber padding	yellow	220
219738	With rubber padding	black	220
219740	Transparent lid, empty	yellow	200
219742	Transparent lid, empty	black	200
C 219744	Transparent lid with pocket and rubber padding	yellow	240
D 219746	Transparent lid with pocket and rubber padding	black	240



4 UltraBox 307

External dimensions: 200 x 98 x 82 mm
Internal dimensions: 170 x 70 x 75 mm

Order no.	Item	Colour	Weight g
A 219748	Empty	yellow	300
B 219750	Empty	black	300
219752	With rubber padding	yellow	320
219754	With rubber padding	black	320
219756	Transparent lid, empty	yellow	300
219758	Transparent lid, empty	black	300
219760	Transparent lid with pocket and rubber padding	yellow	340
219762	Transparent lid with pocket and rubber padding	black	340



6 UltraBox 408

External dimensions: 231 x 150 x 108 mm
Internal dimensions: 200 x 120 x 100 mm

Order no.	Item	Colour	Weight g
219780	Empty	yellow	400
219782	Empty	black	400
219784	With rubber padding	yellow	420
219786	With rubber padding	black	420
219788	Transparent lid, empty	yellow	400
219790	Transparent lid, empty	black	400
C 219789	Transparent lid with pocket and rubber padding	yellow	440
D 219791	Transparent lid with pocket and rubber padding	black	440



5 UltraBox 308

External dimensions: 231 x 150 x 73 mm
Internal dimensions: 200 x 120 x 65 mm

Order no.	Item	Colour	Weight g
219764	Empty	yellow	300
219766	Empty	black	300
E 219768	With rubber padding	yellow	320
F 219770	With rubber padding	black	320
219772	Transparent lid, empty	yellow	300
219774	Transparent lid, empty	black	300
219776	Transparent lid with pocket and rubber padding	yellow	340
219778	Transparent lid with pocket and rubber padding	black	340



Accessories:

Order no.	Item	Weight g
219792	Lid pocket X06 for UltraBox 206/406	20
219794	Lid pocket X07 for UltraBox 207/307	20
219796	Lid pocket X08 for UltraBox 308/408	20

Watertight case UltraCase

These extremely robust cases with surrounding O-ring seal will reliably protect your equipment from water & dust. The cases are the ideal protection for sensitive equipment (e.g. cameras, measuring devices). Manufactured from tough ABS, unbreakable in fall of up to 2 m onto concrete. The automatic pressure equalisation valve ensures that the box is easy to open, even after drastic pressure and temperature changes.



Features:

- Ergonomically padded folding handle
- Bracket for padlock
- You can adjust the pluck foam in a suitable way yourself
- ABS snap locks
- Stackable
- Hinge across the entire width with stainless steel hinge pins

UltraCase 613

External dimensions: 358 x 269 x 155 mm

Internal dimensions: 340 x 226 x 142 mm

Order no.	Item	Colour	Weight g
219812	Empty	yellow	2230
219814	Empty	black	2230
219816	With pluck foam	yellow	2330
219818	With pluck foam	black	2330



Foam inlay examples

UltraCase 716

External dimensions: 447 x 297 x 180 mm

Internal dimensions: 429 x 254 x 165 mm

Order no.	Item	Colour	Weight g
219820	Empty	yellow	2730
219822	Empty	black	2730
219824	With pluck foam	yellow	2830
219826	With pluck foam	black	2830

UltraCase 518

External dimensions: 472 x 368 x 150 mm

Internal dimensions: 452 x 325 x 130 mm

Order no.	Item	Colour	Weight g
219828	Empty	yellow	3230
219830	Empty	black	3230
219832	With pluck foam	yellow	3500
219834	With pluck foam	black	3500

UltraCase 718

External dimensions: 472 x 368 x 196 mm

Internal dimensions: 452 x 325 x 173 mm

Order no.	Item	Colour	Weight g
219836	Empty	yellow	4180
219838	Empty	black	4180
219840	With pluck foam	yellow	4380
219842	With pluck foam	black	4380

UltraCase 821

External dimensions: 551 x 376 x 234 mm

Internal dimensions: 531 x 328 x 213 mm

Order no.	Item	Colour	Weight g
219844	Empty	yellow	5580
219846	Empty	black	5580
219848	With pluck foam	yellow	5800
219850	With pluck foam	black	5800



Watertight case LoadoutCase with wheels

These extremely robust wheeled cases with surrounding O-ring seal and reinforced walls round off the range of UK cases. Of course, these cases will also reliably protect your equipment from water and dust. Because of their size and stability, they can also provide bigger measuring devices and other sensitive objects with reliable protection. With the extendable handle and the large wheels (66 mm Ø) they will even transport extremely heavy equipment from A to B with ease. Made from tough ABS. The automatic pressure equalisation valve ensures that the box is easy to open, even after drastic pressure and temperature changes.



LoadoutCase 827

External dimensions: 732 x 511 x 246 mm
Internal dimensions: 681 x 452 x 208 mm

Order no.	Item	Colour	Weight g
219878	Empty	black	10328
219880	With pluck foam	black	11680
219928	Pluck foam set		1350

LoadoutCase 1022

External dimensions: 605 x 511 x 310 mm
Internal dimensions: 554 x 452 x 274 mm

Order no.	Item	Colour	Weight g
219882	Empty	black	10442
219884	With pluck foam	black	11753
219930	Pluck foam set		1350

Features:

- Six stainless, ergonomic steel folding handles
- T-screw locks
- Bracket for padlock
- Stackable
- Stainless steel hinge pins

LoadoutCase 822

External dimensions: 605 x 511 x 246 mm
Internal dimensions: 554 x 452 x 208 mm

Order no.	Item	Colour	Weight g
219874	Empty	black	9421
219876	With pluck foam	black	10478
219926	Pluck foam set		1050

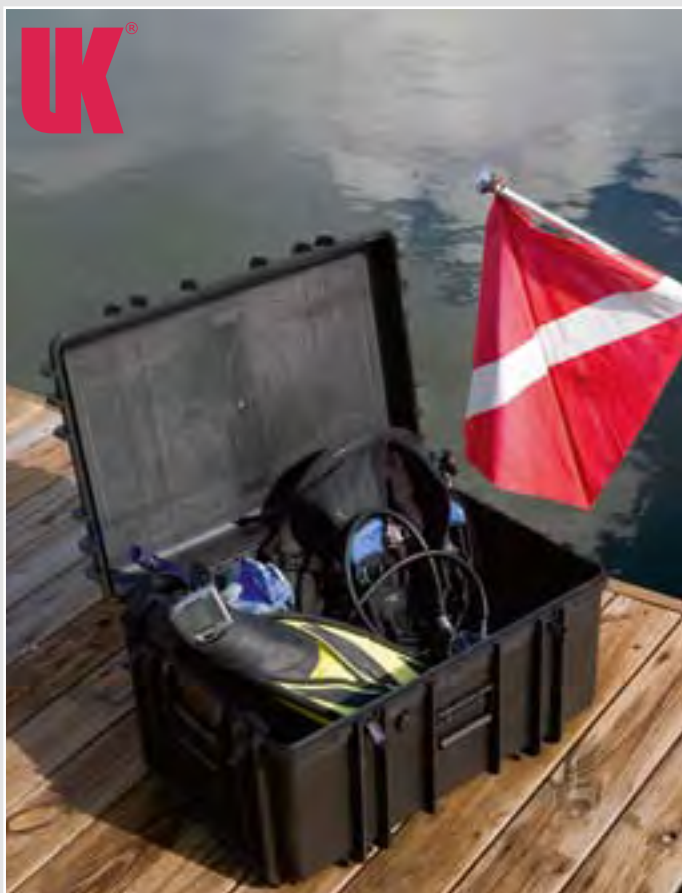

**LoadoutCase 1027**

External dimensions: 732 x 511 x 310 mm
Internal dimensions: 681 x 452 x 274 mm

Order no.	Item	Colour	Weight g
219886	Empty	black	11517
219888	With pluck foam	black	13177
219932	Pluck foam set		1650

LoadoutCase 1122

External dimensions: 605 x 511 x 310 mm
Internal dimensions: 554 x 452 x 274 mm

Order no.	Item	Colour	Weight g
219890	Empty	black	10160
219892	With pluck foam	black	11671
219934	Pluck foam set		1500

LoadoutCase 1127

External dimensions: 732 x 511 x 310 mm
Internal dimensions: 681 x 452 x 274 mm

Order no.	Item	Colour	Weight g
219894	Empty	black	11118
219896	With pluck foam	black	12973
219936	Pluck foam set		1850

LoadoutCase 1322

External dimensions: 605 x 511 x 376 mm
Internal dimensions: 554 x 452 x 340 mm

Order no.	Item	Colour	Weight g
219898	Empty	black	11149
219900	With pluck foam	black	12887
219938	Pluck foam set		1730

LoadoutCase 1327

External dimensions: 732 x 511 x 376 mm
Internal dimensions: 681 x 452 x 340 mm

Order no.	Item	Colour	Weight g
219902	Empty	black	12283
219904	With pluck foam	black	14470
219940	Pluck foam set		2180



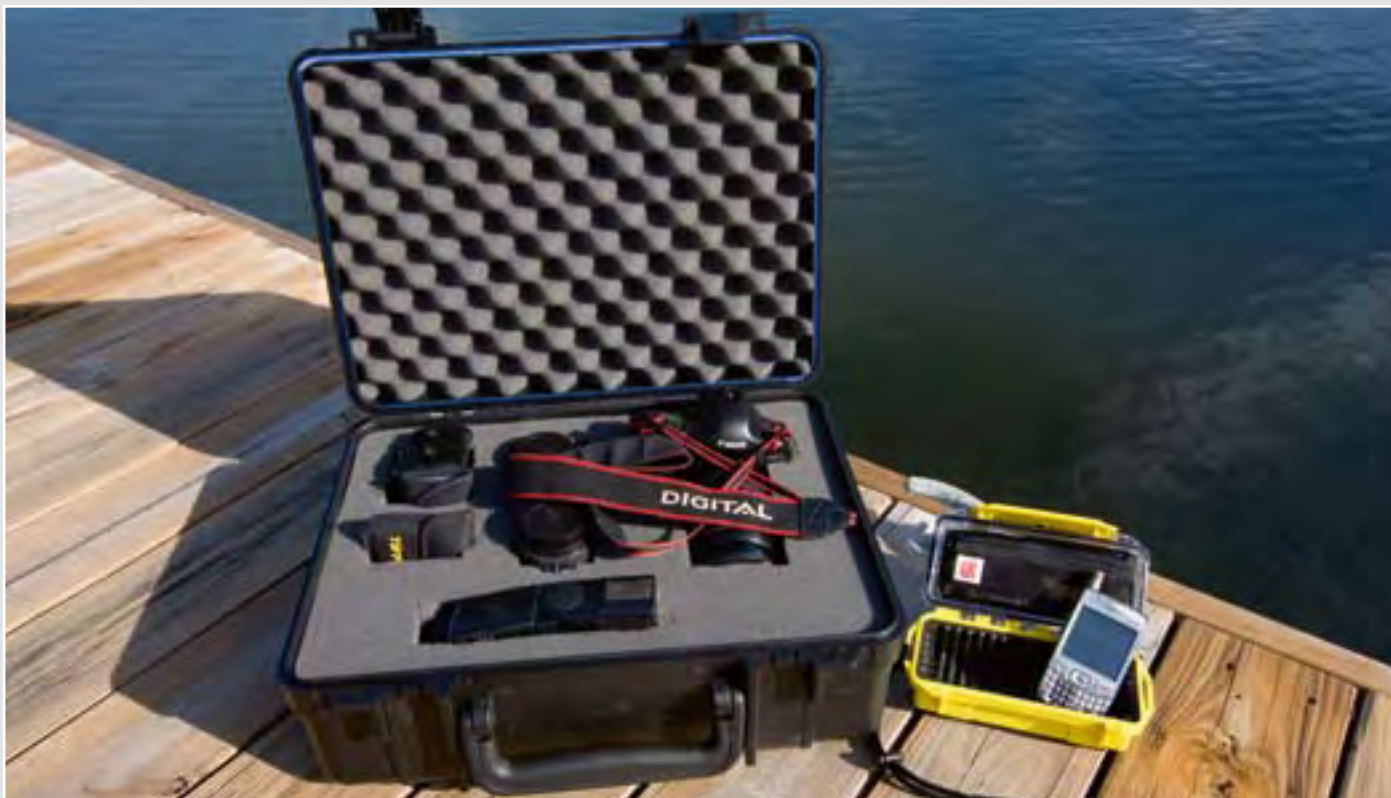

LoadoutCase 1422

External dimensions: 605 x 511 x 376 mm
Internal dimensions: 554 x 452 x 338 mm

Order no.	Item	Colour	Weight g
219906	Empty	black	11140
219908	With pluck foam	black	12723
219942	Pluck foam set		1580

LoadoutCase 1627

External dimensions: 732 x 511 x 437 mm
Internal dimensions: 681 x 452 x 404 mm

Order no.	Item	Colour	Weight g
219918	Empty	black	13154
219920	With pluck foam	black	15762
219948	Pluck foam set		2600

LoadoutCase 1427

External dimensions: 732 x 511 x 376 mm
Internal dimensions: 681 x 452 x 338 mm

Order no.	Item	Colour	Weight g
219910	Empty	black	11948
219912	With pluck foam	black	14197
219944	Pluck foam set		2250

LoadoutCase 1622

External dimensions: 605 x 511 x 437 mm
Internal dimensions: 554 x 452 x 404 mm

Order no.	Item	Colour	Weight g
219914	Empty	black	11948
219916	With pluck foam	black	14061
219946	Pluck foam set		2100



Zarges Euro boxes

Whether in the material warehouse or the emergency vehicle: Materials and equipment are always properly stowed away with Zarges Euro boxes. A wide variety of sizes and equipment variants and perfectly coordinated accessories provide the right solution for any usage area.

Features:

- Extremely strong, corrosion-resistant aluminium alloy
- Hinges made from stainless steel
- Foam-packed lid seal for dust and water spray protection
- Stiffening beads
- Lid retaining straps
- Locked with lead seal, padlock (max. 6 mm bracket thickness) or lock installation possible
- Can be stacked safely and centrally
- Bottom, edge and lid profile frame made from full profile, joint fully welded
- Ergonomic, extremely strong spring-loaded flip handles
- Boxes 258051 and 258057 are supplied with a handle on the front. All other boxes are also available with a third handle on request

Order no.	Dimensions mm (outer)	Weight g
258050	400 x 300 x 340	3000
258051	600 x 400 x 250	4700
258052	600 x 400 x 340	4900
258053	600 x 400 x 410	5200
258054	800 x 400 x 340	6100
258055	800 x 600 x 410	7500
258056	800 x 600 x 610	8900
258057	1200 x 300 x 250	6300



made
in
Germany

exclusive **DÖNNGES**

Oxygen box

We have developed this box for storing and reliably transporting 2 l oxygen cylinders. Up to six cylinders can be reliably stored and transported.

The foam rubber inlay is suitable for cylinders with a diameter of up to 102 mm and a maximum length of 440 mm

Order no.	Dimensions L x W x H mm	Weight g
258058	400 x 300 x 460 box, empty	4000
258066	400 x 300 x 460 box with insert	4400



Example configuration
Supplied without contents



Example configuration, supplied without contents

Attaché insert

Made from hard-wearing fabric. The practical folder for papers or documents.

Suitable for Eurobox 285051 to 285056.

Order no.	Dimensions L x W mm	Weight g
258059	430 x 290	700

Tool bag

Removable, transportable storage bag for tools or equipment.

Suitable for Eurobox 285051 to 285056.

Order no.	Dimensions L x W mm	Weight g
258060	435 x 260	1100



Example configuration, supplied without contents



Partition wall set

Made from top quality foam materials.

Individual system for large components.

Suitable for Eurobox 285051 to 285053.

Order no.	Dimensions L x W x H mm	Weight g
258062	550 x 350 x 190	1200



Aluminium partition wall set

Consisting of a partition wall with two latch strips. Provides additional organisation in the Euro box.

Order no.	Suitable for	Weight g
258063	258051	300
258064	258052, 258053, 258054	500

Small part box

With 21 plug-in dividers made from PP. Ideal for all kinds of small parts. Removable. Suitable for Eurobox 285051 to 285054.

Order no.	Dimensions L x W x H mm	Weight g
258061	430 x 330 x 60	1050

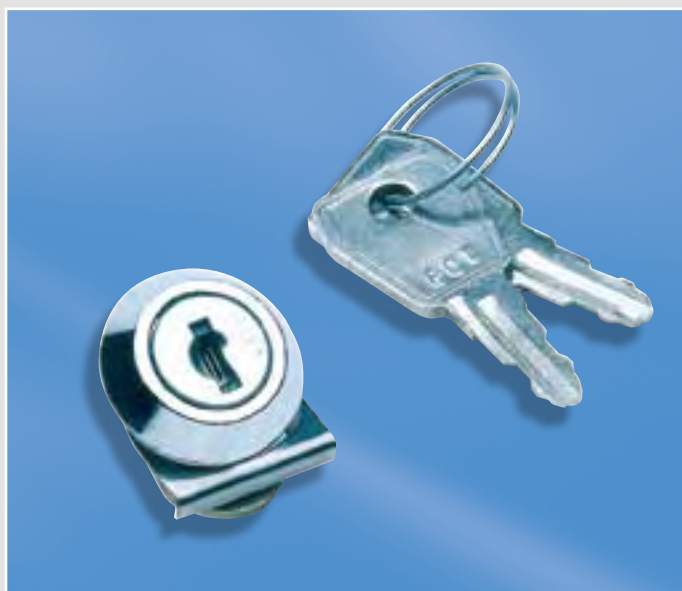

Lock set

Consisting of two locks and two keys. Fits all Euro boxes. Several sets available keyed alike on request.

Order no.	Weight g
258065	100

The Zarges box for the fire brigade area

Dönges and Zarges collaborate in the fire brigade and rescue area and are bringing a modern storage concept that is compliant with DIN 14880:2007-06 onto the market.

Advantages of the Firebox®:

- Stackable in Euro pallet dimensions, the special centring frame in the lid means that small crates can be safely stacked on the bigger versions
- Extremely sturdy, quality that has been tried and tested millions of times from market leader Zarges
- Extremely light, e.g. the DIN 14881 fire brigade toolkit weighs about 7 kg less in this crate
- Protected from dust and water spray in acc. with IP 44
- Non-rusting and long-lasting because of extremely strong aluminium alloy
- Easy to carry because of large ergonomic handles
- Different internal equipment, foam rubber inserts, small parts boxes etc. available on request. Both fixed dividers and flexible systems are possible
- Lockable/sealable with padlock



DIN 14880-x	Boxes		Baskets	
	Mod. W x H x D mm	Arrangement Handles	Weight g	Arrangement Handles
1	600 x 220 x 400	A/B/C/D	5800	B/D 3900
2	400 x 220 x 300	A/B/D/E	3800	B/D 1900
3	600 x 150 x 400	A/B/D	5100	B/D 3100
4	400 x 150 x 300	A/B/D	3300	B/D 1300
5	600 x 220 x 265	B/D/E	4900	B/D 2500
6	800 x 330 x 400	A/B/C/D	7900	B/D 6900

Drawing

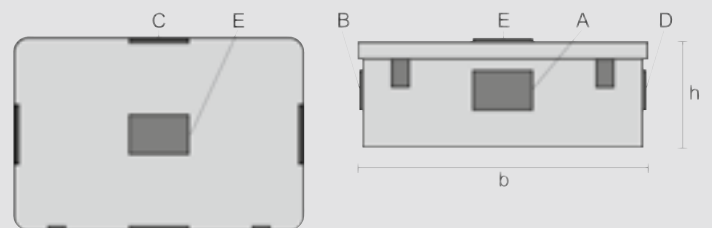

Why is the Firebox® so good?

Zarges has manufactured millions of aluminium boxes since the 1950's. The company therefore has unique know-how and manufacturing technology. Attention is always paid to top quality workmanship and the best components.

Many features such as the foamed-on lid seal are only available in this form from Zarges:

- Welded profile frame joints (lid, upper and lower frame profile) = greater stability
- The inner size is not reduced by the upper edge profile
- PU foam seal made permanently foamed to the lid panel
- Corner beads for even more sturdiness
- Stainless steel hinge, secured with full rivets
- Stainless steel connections with strong stainless steel brackets and sturdy full rivet connection
- Ergonomic, plastic coated spring-loaded flip handles with 11 x 5 cm clearance = easy to operate even when wearing thick gloves. Handles secured with full rivets
- Two extremely strong belt bands, secured with full rivets
- Lid and wall panel thickness 1.35 mm
- Bottom lined with Ethafoam 220 – no rattling, no scratching, no slipping



Foamed-on seal

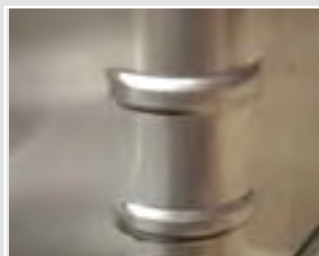

Corner beads



Stainless steel connections



Large spring-loaded flip handles



1.35 mm plate thickness



Well thought-out lining



Variable sets of dividers for the Firebox®

The different Fireboxes® can also be supplied with variable partitioning sets on request. They consist of a surrounding Ethafoam profile into which compressed wood dividers can be inserted. This variable dividing facility is suitable for smaller Fireboxes® and lightweight contents.

For heavy contents such as DIN toolsets, sets of lock tools etc. we strongly recommend the fixed aluminium plate dividers that we use. They reliably keep the contents in the provided compartments even under considerable strain, and are not sensitive to moisture or other external influences. For this reason, all Fireboxes® with DIN contents are supplied with riveted aluminium plate dividers as standard.

Dönges Firebox® made by Zarges, transport box DIN 14880

Aluminium box, empty, without internal dividers or lettering with individual lettering on request.

By collaborating with Zarges we have succeeded in implementing the specifications of DIN 14880:2007-06 in the best possible way and working out a modern logistics concept for the fire brigade area.

Size 1

Order no.	Dimensions mm	Size	Weight g
1 214005	600 x 400 x 220	1	5800
214006	Variable dividers		880

Size 2

Order no.	Dimensions mm	Size	Weight g
2 214010	400 x 300 x 220	2	3800
214011	Variable dividers		880

Size 3

Order no.	Dimensions mm	Size	Weight g
3 214015	600 x 400 x 150	3	5100
214016	Variable dividers		880

Size 4

Order no.	Dimensions mm	Size	Weight g
4 214020	400 x 300 x 150	4	3300
214021	Variable dividers		450

Size 5

Order no.	Dimensions mm	Size	Weight g
5 214025	600 x 265 x 220	5	4500
214026	Variable dividers		650

Size 6

Order no.	Dimensions mm	Size	Weight g
6 214030	800 x 400 x 330	6	7900
214031	Variable dividers		1200



Dönges Firebox® made by Zarges, transport box DIN 14880

Aluminium box, empty, some with partial inner partitioning and lettering for special equipment sets in acc. with DIN 14800, 14142, 14881 and 14885.

The partitions consist of extremely strong aluminium plates, which are permanently secured with non-rusting rivets. The different Fireboxes® can also be supplied with variable partitioning sets on request. The lettering consists of high-strength, wear resistant yellow stickers. The different sets can therefore easily be recognised during darkness and from a long distance. Standard language german, with individual lettering on request.

First aid kit DIN 14142-K

Partitioned with dividing plates.

Order no.	Dimensions mm	Size	Weight g
1 214035	400 x 300 x 150	4	3800

Chimney tools DIN 14800-SSWK

(DIN 14800-4)

Order no.	Dimensions mm	Size	Weight g
2 214040	600 x 400 x 220	1	5800

Multipurpose hoist DIN 14800-MZ 16

(DIN 14800-5)

Partitioned with dividing plates.

Order no.	Dimensions mm	Size	Weight g
3 214045	600 x 400 x 220	1	6300

Accessories for MZ 16

(DIN 14800-5)

Order no.	Dimensions mm	Size	Weight g
4 214050	600 x 400 x 220	1	6300

Multipurpose hoist DIN 14800-MZ 32

(DIN 14800-5)

Partitioned with dividing plates.

Order no.	Dimensions mm	Size	Weight g
5 214055	800 x 400 x 330	6	7900

Metalworking tools 1 DIN 14800-WKM 1

(DIN 14800-9)

Partitioned with dividing plates.

Order no.	Dimensions mm	Size	Weight g
6 214060	600 x 400 x 150	3	5600

Individual lettering on request.



made in Germany

exclusive

Metalworking tools 2 DIN 14800-WKM 2

(DIN 14800-9)

Partitioned with dividing plates.

	Order no.	Dimensions mm	Size	Weight g
1	214065	600 x 400 x 150	3	5600

Woodworking tools DIN 14800-WKH

(DIN 14800-9)

Partitioned with dividing plates.

	Order no.	Dimensions mm	Size	Weight g
2	214070	600 x 400 x 150	3	5600

Sealing material DIN 14800-DK

(DIN 14800-10)

	Order no.	Dimensions mm	Size	Weight g
3	214075	400 x 300 x 150	4	3300

**Lifting cushion accessories DIN 14800-HZK**

(DIN 14800-11)

Partitioned with dividing plates.

	Order no.	Dimensions mm	Size	Weight g
4	214080	800 x 400 x 330	6	7900

Lock picking tools DIN 14800-SWK

(DIN 14800-12)

Partitioned with dividing plates.

	Order no.	Dimensions mm	Size	Weight g
5	214085	400 x 300 x 150	4	3800

Traffic accident DIN 14800-VUK

(DIN 14800-13)

Partitioned with dividing plates.

	Order no.	Dimensions mm	Size	Weight g
6	214090	600 x 400 x 220	1	6300

Individual lettering
on request.

made
in
Germany

exclusive

Consumables DIN 14800-VMK

(DIN 14800-14)

Order no.	Dimensions mm	Size	Weight g
1 214095	400 x 300 x 150	4	3300

Environmental damage DIN 14800-USK

(DIN 14800-15)

Order no.	Dimensions mm	Size	Weight g
2 214100	600 x 400 x 220	1	5800

Hand tools DIN 14881-FWKa

Partitioned with dividing plates.

Order no.	Dimensions mm	Size	Weight g
3 214101	600 x 400 x 150	3	5600

Electrical tools DIN 14885

Partitioned with dividing plates.

Order no.	Dimensions mm	Size	Weight g
4 214102	400 x 300 x 150	4	3800



made in Germany

exclusive

Dönges Firebox® made by Zarges, Transport basket DIN 14880

Aluminium basket, empty, without cover and without internal partitioning, perforated side walls for better ventilation of the stored objects. Particularly suitable for storing damp or wet equipment after operations.

All of the advantages of the Fireboxes® also apply to this lightweight type of transport box for storing in the vehicle.

Order no.	Dimensions mm	Size	Weight g
214103	600 x 400 x 220	1	3900
214104	400 x 300 x 220	2	1900
214105	600 x 400 x 150	3	3100
214106	400 x 300 x 150	4	1300
214107	600 x 265 x 220	5	2500
214108	800 x 400 x 330	6	6900

Hand tools DIN 14881-FWKa

The hand tool box with new configuration in accordance with revised DIN 14881:2005-02.

In Dönges Firebox® made by Zarges in acc. with DIN 14881-3-LM (600 x 400 x 150 mm) with aluminium dividers and "Handwerkzeuge" lettering with individual lettering on request.



Individual lettering on request.

Order no.	Item	Weight g
211020	Toolbox DIN 14881 complete	23500
214101	Box DIN 14880-3-LM-W empty	5600
211021	Set hand tool DIN 14881 (without box)	17900
217005	Slotted screwdriver, insulated 2.5 mm	20
212311	Slotted screwdriver, 4 mm	40
212316	Slotted screwdriver, 6.5 mm	80
212320	Slotted screwdriver, 8 mm	140
211055	Phillips screwdriver size 1	40
211056	Phillips screwdriver size 2	90
211057	Phillips screwdriver size 3	140
217095	Offset screwdriver, slotted A1 x 5.5	25
280105	Offset screwdriver, Phillips PH 1 x 2	25
217010	Allen key, long 1.5 mm	5
217015	Allen key, long 2 mm	5
217020	Allen key, long 2.5 mm	5
217025	Allen key, long 3 mm	10
217030	Allen key, long 4 mm	20
217035	Allen key, long 5 mm	30
217040	Allen key, long 6 mm	50
217045	Allen key, long 8 mm	100
217050	Allen key, long 10 mm	175
217055	Allen wrench (Torx) T 10	5
217060	Allen wrench (Torx) T 15	5
217065	Allen wrench (Torx) T 20	10
217070	Allen wrench (Torx) T 25	15

Order no.	Item	Weight g
217075	Allen wrench (Torx) T 27	25
217080	Allen wrench (Torx) T 30	30
217085	Allen wrench (Torx) T 40	45
217090	Allen wrench (Torx) T 45	65
211070	Combination spanner 8 mm	20
211071	Combination spanner 10 mm	40
211072	Combination spanner 11 mm	40
217100	Combination spanner 12 mm	50
211073	Combination spanner 13 mm	65
211074	Combination spanner 14 mm	85
217105	Combination spanner 15 mm	90
217110	Combination spanner 16 mm	115
211075	Combination spanner 17 mm	125
217111	Combination spanner 18 mm	130
211076	Combination spanner 19 mm	170
217115	Combination spanner 21 mm	230
211077	Combination spanner 22 mm	225
211078	Combination spanner 24 mm	300
211079	Combination spanner 27 mm	420
217120	Combination spanner 30 mm	520
217125	Combination spanner 32 mm	520
280106	Adjustable spanner 200 mm	240
216008	Set of hexagon socket wrenches 3/8" in box	1600
212260	Bitting gauge	120
217130	Switch cabinet spanner	75
280504	Engineer's hammer 500 g	620
280428	Pin punch 4 mm	75
211875	Edge pliers 250 mm	300
280204	VDE diagonal cutters 160 mm	200
211851	VDE combination pliers cutters 160 mm	200
211484	VDE snipe nose pliers 200 mm	210
280107	Vice-grip wrench 250 mm	540
211850	Slip joint pliers 240 mm	300
212025	Corner pipe clamp 1-1/2"	1700
280108	Metal bow saw 300 mm	570
211030	Saw blades, double sided (10 pcs.)	45
210330	Levering bar 400 mm	900
280406	Flat chisel 200 mm	390
212493	Safety knife	85
217135	Tape measure 3 m	100
280100	Safety goggles	65

The quantity that is specified in brackets specifies the quantity contained in the set.



made
in
Germany

exclusive **DÖNGES**

Metalworking tools 1 DIN 14800-WKM 1

In acc. with DIN 14800-9:2005-02.

In Dönges Firebox® made by Zarges in acc. with DIN 14880-3-LM (600 x 400 x 150 mm) with aluminium dividers and "Werkzeug Metall 1" lettering with individual lettering on request.

Individual lettering on request.



Order no.	Item	Weight g
217150	Metalworking toolbox 1, complete	23425
214060	Box DIN 14880-3-LM-9.1 empty	5600
217155	Set metal tool 1 (without box)	17825
280222	Double-ended open-jawed spanner set W/F 6 - 32 mm	2200
217162	Combination spanner set W/F 6 - 32 mm	4790
280504	Engineer's hammer 500 g	620
212311	Slotted screwdriver, 4 mm	40
211054	Slotted screwdriver, 5.5 mm	75

Order no.	Item	Weight g
212316	Slotted screwdriver, 6.5 mm	80
217167	Slotted screwdriver, 8 mm	150
212326	Slotted screwdriver, 10 mm	160
212327	Slotted screwdriver, 12 mm	235
280109	Slotted screwdriver C 5.5 mm	70
280110	Slotted screwdriver C 7 mm	105
280111	Slotted screwdriver C 9 mm	135
280112	Slotted screwdriver C 14 mm	305
211039	Slotted screwdriver, 2.5 mm	25
212311	Slotted screwdriver, 4 mm	40
280113	Slotted screwdriver, short 6.5 mm	100
217095	Offset screwdriver, slotted A1 x 5.5	25
280105	Offset screwdriver, Phillips PH 1 x 2	25
217175	Offset screwdriver, Phillips PH 3 x 4	75
211055	Phillips screwdriver size 1	40
211056	Phillips screwdriver size 2	90
211057	Phillips screwdriver size 3	140
280114	Phillips screwdriver, short size 1	75
280115	Allen key set W/F 2 - 10 mm	725
280116	Allen key W/F 12 mm	15
280117	Allen key W/F 14 mm	15
217180	Set of hexagon socket wrenches 1/2" in box	6000
216025	Socket spanner insert 1/2", T20	70
216035	Socket spanner insert 1/2", T25	70
216045	Socket spanner insert 1/2", T27	80
216050	Socket spanner insert 1/2", T30	80
216060	Socket spanner insert 1/2", T40	90
216070	Socket spanner insert 1/2", T45	90
216080	Socket spanner insert 1/2", T50	90
216090	Socket spanner insert 1/2", T55	110
216100	Socket spanner insert 1/2", T60	110
280118	Adjustable spanner 150 mm	130
280119	Adjustable spanner 300 mm	700



made in Germany

exclusive **DÖNGES**

Metalworking tools 2 DIN 14800-WKM 2

In acc. with DIN 14800-9:2005-02.

In Dönges Firebox® made by Zarges in acc. with DIN 14880-3-LM (600 x 400 x 150 mm) with aluminium dividers and "Werkzeug Metall 2" lettering with individual lettering on request.

Individual lettering
on request.



Order no.	Item	Weight g
217200	Metalworking toolbox 2, complete	16760
214065	Box DIN 14880-3-LM-9.2 empty	5600
217205	Set Metalworking tool 2 (without box)	11160
280514	Club hammer 2 kg	2200
280424	Pin punch 2 mm	65
280428	Pin punch 4 mm	70
280434	Pin punch 8 mm	115
211875	Edge pliers 250 mm	300
211025	Metal bow saw	600
211030	Saw blades, double sided (5 pcs.)	45
217210	Saw bow, design C	225
217211	Saw blade for saw bow, design C (5 pcs.)	10
217215	Tape measure 5 m	130
280120	Corner pipe clamp 1"	785
280408	Flat chisel 250 mm	490
280121	Flat chisel 400 mm	830
280122	Pointed chisel 400 mm	965
211851	VDE combination pliers cutters 160 mm	200
280204	VDE diagonal cutters 160 mm	200
211850	Slip joint pliers 240 mm	300
211852	Slip joint pliers 400 mm	400
280107	Vice-grip wrench 250 mm	540
280123	Plate shears 250 mm	450
280124	Rubber mallet Ø 90 mm, 600 g	840
280125	Folding rule 2 m	130
280126	Leak indicator spray	530

The quantity that is specified in brackets specifies the quantity contained in the set.



made
in
Germany

exclusive **DÖNGES**

**Woodworking tools
DIN 14800-WKH**

In acc. with DIN 14800-9:2005-02.

In Dönges Firebox® made by Zarges in acc. with DIN 14880-3-LM (600 x 400 x 150 mm) with aluminium dividers and "Werkzeugsatz Holz" lettering with individual lettering on request.



Order no.	Item	Weight g
217160	Woodworking tool box, complete	23680
214070	Box DIN 14880-3-LM-9.3 empty	5600
217165	Woodworking tool set (without box)	18080
280530	Roofing hammer (2 pcs.)	600
280127	Firmer chisel 14 mm	120
280128	Mortise chisel 35 mm	550
280038	Piercing saw 350 mm	160
217260	Fibre glass measuring tape 30 m	405
280125	Folding rule 2 m (2 pcs.)	130
280440	Hatchet 600 g	800
280129	Steel carpenter's square 500 mm	350
280130	Sliding square 330 mm	220
280131	Carpenter's pencil (10 pcs.)	15
280132	Carpenter's mallet	400
217265	Spirit level 500 mm	330
280133	Vices 200 x 100 mm (2 pcs.)	1315
280134	Vices 400 x 175 mm (4 pcs.)	2700

The quantity that is specified in brackets specifies the quantity contained in the set.



Individual lettering on request.



made in Germany

exclusive DÖNGES

Electrical tools DIN 14885

In acc. with DIN 14885:2009-03, in Dönges Firebox® made by Zarges in acc. with DIN 14880-4-LM (400 x 300 x 150 mm) with aluminium dividers and "Electrical tools-only for electrical experts and persons trained in "Werkzeugkasten E" lettering with individual lettering on request.



Individual lettering
on request.

Order no.	Item	Weight g
217805	Box of electrical tools, complete	10180
214102	Box DIN 14880-4-LM-E empty	3800
217810	Set (excluding box)	6380
217310	Safety voltage tester, IP 65	460
217315	Sign DIN 4844-D-S001-200-de (2 pcs.)	15
217321	Sign DIN 4844-D-H003-200-de	15
211130	VDE screwdriver 3.5	80
211135	VDE screwdriver 5.5	120
211140	VDE screwdriver 6.5	160
211145	VDE screwdriver 8	220
211151	VDE screwdriver 10	280
211484	VDE snipe nose pliers 200 mm	360
211019	VDE high-leverage diagonal cutters 200 mm	340
211165	VDE single ended open-jaw spanner 10 mm	40
211166	VDE single ended open-jaw spanner 11 mm	50
211167	VDE single ended open-jaw spanner 12 mm	50
211168	VDE single ended open-jaw spanner 13 mm	60
211169	VDE single ended open-jaw spanner 14 mm	60
211170	VDE single ended open-jaw spanner 15 mm	60
211175	VDE slip-on handle for NH	540
211180	Insulating tape	40
211185	Marking chalk	20
211190	"Do not operate - danger" sticker	10
217640	Packet of cable ties 360 mm (100 pcs.)	240
217840	VDE screwdriver PH 1	160
217843	VDE screwdriver PH 2	220
217845	VDE screwdriver PH 3	300

The quantity that is specified in brackets specifies the quantity contained in the set.



Safety voltage
tester on page 160

made
in
Germany

exclusive **DÖNGES**

Chimney tools DIN 14800-SSWK

In acc. with DIN 14800-4:2005-02.

In Dönges Firebox® made by Zarges in acc. with DIN 14880-1-LM (600 x 400 x 220 mm) with "Schornsteinwerkzeug" lettering with individual lettering on request.

Completely new concept with toolkit divided into two parts. The box contains a handy bag with shoulder strap for "top" cleaning. The other parts are for "bottom" cleaning and remain in the box.

Kit includes two springs steel rods that are not depicted. They will not fit in the box!

Individual lettering
on request.



Order no.	Item	Weight g
217300	Box, complete with 20 m chain	25000
217305	Box, complete with 30 m chain	27700
214040	Box DIN 14880-1-LM-4 empty	5800
217380	Bag for "top cleaning"	2500
217815	Kit with 20 m chain (without box)	19200
217820	Kit with 30 m chain (without box)	21900
217320	Drop weight 4 kg	4000
217325	Kugelschlagapparat, complete	900
217330	Chain 20 m	5400
211234	Chain 30 m	8100
217335	Line star, medium hard 250 mm Ø	100
217340	Scraping spring insert 160 mm Ø	200
217345	Scraping spring insert 200 mm Ø	300
217348	Scraping spring insert 240 mm Ø	500
211246	Shoulder iron, short (2 pcs.)	600
217355	Star spanner (2 pcs.)	200
217360	Heat-resistant gloves (1 pair)	300
211240	Fireplace mirror with telescopic handle (2 pcs.)	200
217361	Spring steel rod 3 m (2 pcs.)	1000
217365	Roller opener	400
217370	Brush with thread 250 mm (2 pcs.)	200
211850	Slip joint pliers 240 mm	300
211040	Philips screwdriver	100
217375	Coal shovel	300

The quantity that is specified in brackets specifies the quantity contained in the set.

made
in
Germany

exclusive **DÖNGES**

Lock picking tools DIN 14800-SWK

In acc. with DIN 14800-12:2005-02.

In Dönges Firebox® made by Zarges in acc. with DIN 14880-4-LM (400 x 300 x 150 mm) with aluminium dividers and "Sperrwerkzeug" lettering" with individual lettering on request.



Order no.	Item	Weight g
217460	Lock picking tool box, complete	8060
214085	Box DIN 14880-4-LM-12 empty	3800
217465	Set of lock picking tools (without box)	4260
211478	Bit holder with T-handle	100
211480	Bit set, 10-piece	120
211421	Torx bit TX-20	10
211470	Pulling screws "Standard", pack of 10	40
211472	Pulling screws "Extra", pack of 10	40
211474	Pulling screws "Super", pack of 10	60
211493	Clamping device for pulling screws	80
211419	WD-40 cutting and sliding oil	240
211491	Pulling device, original "Glocke"	1160
211476	Proxxon Speeder ratchet, W/F 17x19	260
212262	Bitting gauge	100
211477	Spare cylinder	160
211495	Hinge lifter	1360
211437	Door latch tool	40
211433	Door latch knife 8 mm	40
211434	Door latch knife 9 mm	40
211435	Door latch knife 10 mm	40
217452	Latch wire for doors with double rebate	10
211429	Door latch spiral opener kit	120
211497	Tilting window openers	160



Individual lettering on request.

made in Germany

exclusive DÖNGES

**Traffic accident tool kit
DIN 14800-VUK**

In acc. with DIN 14800-13:2005-02.

In Dönges Firebox® made by Zarges in acc. with DIN 14880-1-LM (600 x 400 x 220 mm) with aluminium dividers and "Verkehrsunfall" lettering with individual lettering on request. The holder for the Glas-Master is riveted inside the lid.



Individual lettering on request.

Order no.	Item	Weight g
217501	Traffic accident box, complete	14245
214090	Box DIN 14880-1-LM-13 empty	6300
217506	Traffic accident set (without box)	7945
217512	Disposable gloves, medium size (4 pairs) each	5
217516	Disposable gloves, large size (4 pairs) each	5
280135	Rescue blanket 2100 x 1600 mm	60
280100	Safety goggles in acc. with DIN EN 166	65
217520	Transparent film, 2000 x 1000 mm (2 pcs.)	1200
280136	Double-ended open-jawed spanner W/F 10 x 11	50
280137	Double-ended open-jawed spanner W/F 12 x 13	70
212435	Belt knife	80
211314	Spring centre punch	60
217525	Knife with serrated edge	120
217530	Engineer's hammer 500 mm	830
217531	Clip lifter	120
212470	Original Glas-Master	1360
217535	Fabric adhesive tape 50 mm x 50 m	250
217540	Chalk gravity marker	25
217545	Wax chalk, yellow	15
217550	Wedge 400 x 100 x 80 mm unplanned (6 pcs.)	260
211019	VDE high-leverage diagonal cutters 200 mm	340

optionally available:

212586	Ratchet lashing strap 5 m, tensile force 2.5 t	2250
217580	Sheet metal cutting chisel with hand guard	430
280504	Engineer's hammer 500 g	620

The quantity that is specified in brackets specifies the quantity contained in the set.



made in Germany

exclusive DÖNGES

Consumables DIN 14800-VMK

In acc. with DIN 14800-14:2005-02.

In Dönges Firebox® made by Zarges in acc. with DIN 14880-4-LM (400 x 300 x 150 mm) with "Verbrauchsmaterial" lettering with individual lettering on request.

Individual lettering
on request.



made
in
Germany

DÖNGES
exclusive

Order no.	Item	Weight g
217601	Box of consumable materials, complete	9250
214095	Box DIN 14880-4-LM-14 empty	3300
217605	Set of consumables (excluding box)	5950
218365	Binding wire 2 mm Ø, length 50 m	1300
217615	Packet of nails, 40 mm (50 pcs.)	250
218205	Packet of nails, 80 mm (50 pcs.)	240
218215	Packet of nails, 120 mm (50 pcs.)	720
217630	Packet of lightweight construction panel nails, 70 mm	250
217535	Fabric adhesive tape 50 mm x 50 m	250
217640	Packet of cable ties 360 mm (100 pcs.)	240
217395	PTFE sealing tape, 12 m roll	20
217650	Sealing stopper 300 mm, Ø 60/10 mm	180
211419	WD-40 cutting and sliding oil	240
280055	Packet of cleaning cloths	2000



Sealing kit DIN 14800-DK

In acc. with DIN 14800-10:2005-02.

In Dönges Firebox® made by Zarges in acc. with DIN 14880-4-LM (400 x 300 x 150 mm) with aluminium dividers and "Dichtungssatz" lettering with individual lettering on request.

Individual lettering
on request.



made
in
Germany

DÖNGES
exclusive

Order no.	Item	Weight g
217400	Box of seals, complete	5680
214075	Box DIN 14880-4-LM-10 empty	3300
217450	Set (without box)	2380
217395	PTFE sealing tape, 2 rolls of 12 m	20
211094	Gas plug and cap set in acc. with EN 10241-DN sizes 8 - 50 (8 pcs.)	1840
217455	Leak-Stop universal sealing paste 500 ml	600

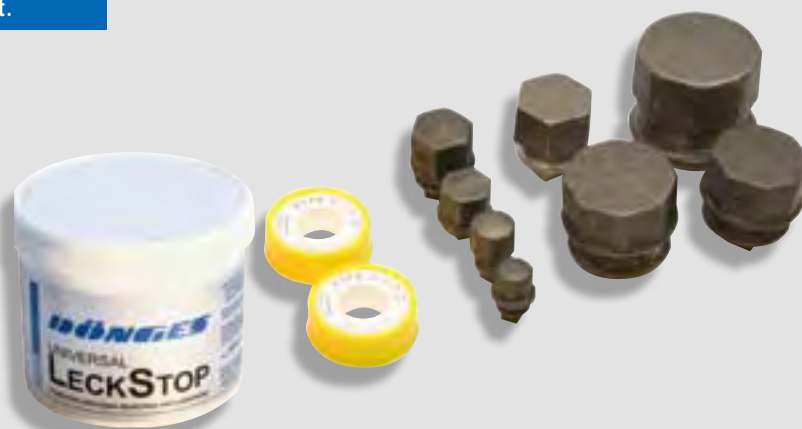

**Environmental damage
DIN 14800-USK**

In acc. with DIN 14800-15:2005-02.
In Dönges Firebox® made by Zarges in acc. with DIN 14880-1-LM (600 x 400 x 220 mm) with "Umwelt-schaden" lettering with individual lettering on request.

Individual lettering on request.



Order no.	Item	Weight g
217850	Environmental damage box, complete	13920
214100	Box DIN 14880-1-LM-15 empty	5800
217855	Environmental damage set (without box)	8120
280056	Oil binding cloths (50 pcs.)	1250
217860	Shaft cover 750 x 750 mm	1200
217865	Screening material tarpaulin with eyes, 4 x 6 m	3650
217870	Securing rope	950
280138	Roll of bin bags	540
217875	Chemical protection suit (2 pcs.)	360

The quantity that is specified in brackets specifies the quantity contained in the set.

made in Germany

exclusive



Tool kit for tool box

6-piece set in box.

Contents:

- 1 x Club hammer 2 kg
- 1 x Engineer's hammer 500 g
- 1 x Flat chisel 300 mm
- 2 x Philips screwdriver 0.8 x 4 and 1.6 x 10 mm
- 1 x Combination pliers 180 mm

Order no.	Item	Weight g
211150	Set in box	3900
280514	Club hammer 2 kg	2200
280504	Engineer's hammer 500 g	620
210210	Flat chisel 300 mm	500
212310	Screwdriver 4 mm	40
212325	Screwdriver 10 mm	160
212010	Combination pliers 180 mm	260



Tool kit, non-sparking RW

For equipment vehicles RW (old standard DIN 14555-T3), made from special bronze or copper beryllium.

Contents:

- 1 x Tool bag leather 610 x 160 x 220 mm
- 1 x Slip joint pliers 250 mm
- 1 x Corner pipe clamp 2"
- 1 x Flat chisel 300 mm with hand guard
- 1 x Copper hammer 1000 g

Order no.	Weight g
211156	7900

Gedore tool assortment 1400

Gedore tools have an excellent reputation all over the world. This rounded assortment contains the basic tools for any workshop.

Empty tool cabinet

With shelf and three drawers, fixed holders for the tools listed below, with security lock, painted blue/silver, 650 x 250 x 970 mm.

Large universal tool assortment

92 pieces, including: Socket wrench set, sets of open ended and ring spanners, socket wrenches, screwdrivers, various pliers, hammers, chisels, files and saws.

Additional equipment for vehicle mechanics

34-piece

Order no.	Item	Weight kg
211162	Tool cabinet, empty	29,0
211163	Large universal assortment	15,0
211164	Additional assortment for vehicles	10,0



made
in
Germany

Compact tool case

The versatile tool case for professionals. The COMPACT tool cases are light, yet still designed for carrying heavy weights.

Made from top quality polypropylene. They are non-wearing, do not distort and cannot rust.

The material is also resistant to the majority of acids and alkalis.

Different dimensions and partitioning are available:

- Compact 15:** incl. dividers
- Compact 20:** incl. 6 inserts
- Compact 27:** 6 inserts and 2 drawers
- Compact 37:** 7 inserts, dividers, 2 folding handles
- Compact 47:** 7 inserts, dividers, 2 drawers
- Compact 50:** 10 inserts and divider
- Compact 62:** 10 inserts, divider, 4 drawers

Order no.	Item	Dimensions H x W x D mm	Weight g
282020	Compact 15	170 x 426 x 215	1400
282021	Compact 20	190 x 475 x 240	1600
282022	Compact 27	250 x 475 x 240	2100
282023	Compact 37	230 x 540 x 296	2200
282024	Compact 47	292 x 540 x 296	2500
282025	Compact 50	260 x 621 x 311	3000
282026	Compact 62	322 x 621 x 311	3300



The illustration shows the Compact 27 model as an example. Supplied without contents.



Toolboxes

Empty, made from steel plate, painted blue, with handle and hole for padlock. Two different versions and three different sizes available:

Three pieces

Order no.	Dimensions L x W x H mm	Weight g
1 282030	430 x 200 x 160	2500

Five pieces

Order no.	Dimensions L x W x H mm	Weight g
2 282032	430 x 200 x 210	3800
282033	530 x 200 x 200	4500



BOSCH

Technik fürs Leben

Professional blue electric tools from Bosch.
By professionals for professionals

Commercial Bosch power tools meet the highest of quality demands! The professional, blue Bosch power tools have been developed for producing top-class results. They meet the performance, precision and robustness requirements for producing excellent work results.

These properties also make them the tools of choice for the fire brigade, the THW and the disaster relief services. You will find a selection of the best equipment for the most important uses here.

Heavy duty cordless screwdriver Bosch GSR 12 VE-2

Sets new standards with regard to performance capability and robustness. The new 2-gear heavy duty cordless screwdriver for the most demanding of jobs. High-torque specialist for the biggest screw diameters and holes. 25 torque levels and drilling settings, clockwise/anticlockwise rotation, shut-off lock, brake.

Features:

- Powerful: excellent torque transmission from newly developed 2-gear planetary drive with metal gearwheels for powerful drilling and screwdriving
- Extremely robust: fully operational, even after a fall onto concrete from height of 2 m due to "Dura Shield" housing
- Longer service life and overloading capability due to new, unique Bosch high-performance motor and the world's first air-cooled gearbox
- Progressively increasing torque makes fine tuning to each screw size possible
- Newly developed auto-lock chuck with high clamping force for bits and drills
- Ergonomically shaped handle with comfort zone in the soft-grip area for secure hold and non-tiring work
- Replaceable carbon brushes

Technical data:

Batt. pack voltage/capacity:	12 Volts/2.6 Ah
Idle speed rpm:	1./2. gear 0-430/0-1650
Chuck clamping range:	1.5 - 13 mm
Drilling Ø in steel/wood:	13/40 mm
Wood screws:	up to 8 mm
max. torque soft/hard:	28/67 Nm

Scope of delivery:

2 x 2.6 Ah NiMH batteries, 60 minute charger, quick-clamping chuck, case

Order no.

217900

Weight kg

2,4



made
in
Germany



Cordless impact screwdriver GSB 18 VE-2-LI

Order no.
217901

Weight kg
2,5

The extremely robust 18-Volt cordless impact screwdriver. For the hardest screwdriving and drilling jobs in wood and metal, and hammer drilling jobs in masonry.

Features:

- Electronic Motor Protection (EMP) protects the motor from overloading and provides a long service life
- Extremely robust: full operational, even after a fall onto concrete from height of 2 m due to flexible "Dura Shield Housing"
- Unique premium lithium ion technology for 400 % longer service life and unbeatable battery service life
- Electronic Cell Protection (ECP): Protects the battery from overloading, overheating and deep discharging
- Specially-tuned gearbox ratio for rapid work progress during drilling and impact drilling operation
- Progressively increasing torque makes fine tuning to each screw size possible
- Ergonomically shaped handle with comfort zone in the soft-grip area for secure hold and non-tiring work
- Hyper-Charge: Quick charging means that the batteries are already 75 % charged after half of the total charging time
- No memory effect: Battery can be charged regardless of charge condition at any time without damaging the cells

Technical data:

Batt. pack voltage/capacity:	18 Volts/2.6 Ah
Idle speed rpm:	1./2. Gear 0-480/0-2050
Chuck clamping range:	1.5 - 13 mm
Hole Ø in	
Steel/wood/masonry:	13/45/15 mm
Wood screws:	up to 10 mm
Max. torque soft/hard:	32/80 Nm

Scope of delivery:

2 x 2.6 Ah Li-ion battery, quick charger, quick clamping chuck, additional handle, case



made
in
Germany



Bit box with universal holder

Practical small set with magnetic 1/4" universal holder and 9 bits.

The tin can also be used as a screwdriver handle.

Contents:

Magnetic holder 1/4"
Slotted bits 4, 5.5 and 7 mm
Phillips bits size 1, 2 and 3
Pozidriv bits size 1, 2 and 3

Order no. Dimensions mm
211480 85 x 47

Weight g
120

Cordless hammer drill GBH 36 V-LI Compact

Lightweight, powerful cordless hammer drill for convenient working. More than 100 holes 6 x 40 mm in concrete with one battery charge.

Features:

- Ideal for overhead work because of its light weight
- Low vibration values for non-tiring work due to Vibration Control
- SDS-plus system for quick bit changes
- Unique premium lithium ion technology for 400 % longer service life and unbeatable battery service life
- Electronic Cell Protection (ECP): Protects the battery from overloading, overheating and deep discharging
- Pneumatic hammer mechanism, optimised for holes from 4 – 10 mm in concrete (max. 18 mm)
- Brushless EC motor: compact, lightweight and absolutely maintenance free
- Hyper-Charge: Because of quick charging, the batteries are already 75% charged after half of the charging time
- No memory effect: Battery can be charged regardless of charge condition without damaging the cells

Technical data:

Batt. pack voltage/capacity:	18 Volts/1.3 Ah
Output:	430 Watts
Drilling Ø in concrete/steel/wood:	18/13/30 mm
Nominal speed:	0 - 1500 rpm
Number of impacts:	0 - 4850 rpm
Impact energy:	1.8 joules

Scope of delivery:

2 x 1.3 Ah Li-ion battery, quick charger, additional handle, depth stop, case

Order no.

217902

Weight kg

2,9



made
in
Germany

Battery-powered hammer drill GBH 36 V-LI

As fast as the best 2 kg mains powered hammer drills because of the latest lithium ion technology and the new pneumatic hammer mechanism.

Features:

- SDS-plus system for quick bit changes
- Drills up to 195 holes with one battery charge due to 36V Li-ion high-performance battery pack (6 x 40 mm in concrete B25)
- Optimised hammer mechanism and special Bosch high-performance motor for the hardest jobs
- Electric motor brake
- Clockwise/anticlockwise rotation slide switch with switch-on lock
- No memory effect: Battery can be charged regardless of charge condition without damaging the cells
- Bosch Electronic Cell Protection (ECP): protects the battery from overloading, overheating and deep discharge

Technical data:

Batt. pack voltage/capacity:	36 Volts/2.6 Ah
Output:	600 Watts
Drilling Ø in concrete/steel/wood:	16/13/30 mm
Nominal speed:	0 - 960 rpm
Number of impacts:	0 - 4260 rpm
Impact energy:	3.0 joules

Scope of delivery:

2 x 2.6 Ah Li-ion battery, quick charger, additional handle with drilling depth stop, case

Order no.

217903

Weight kg

4,3



made
in
Germany

**Hammer drill
GBH 2-26 DRE Professional**

Lightweight, efficient hammer drill with optimised hammer mechanism. Rotation stop for delicate chipping work. Also suitable for screwdriving due to clockwise/anticlockwise rotation.

Features:

- SDS-plus system for quick bit changes
- Superior drilling performance
- Replaceable tool holder
- Rotating brush plate (for equal power during clockwise and anticlockwise rotation)
- 50 mm spindle collar diameter for additional robustness
- Rotation stop for chiselling
- Hammer stop for drilling on wood and steel
- Grommet for preventing cable breaks
- Softgrip on main handle and additional handle
- Overload clutch

Technical data:

Power consumption:	800 Watts
Hole Ø in	
concrete/steel/wood:	68/13/30 mm
Nominal speed:	0 - 900 rpm
Operating speed:	0 - 4000 rpm
Impact energy:	3.0 joules

Scope of delivery:

Adapter and toothed ring chuck 1.5 - 13 mm, additional handle with drilling depth stop, case

Order no.	Weight kg
217905	2,7



made
in
Germany



**Set of accessories
for lightweight hammer RW**

Complies with DIN 14555-T3 (equipment vehicle loading).

Contents:

- 1 x Universal holder with SDS-plus shank, quick change chuck and permanent magnet
- 1 set Masonry drills with SDS-plus shank, diameter: 5, 6, 8, 10 and 12 mm in sheet steel box
- 1 set Spiral drills DIN 338 HSS, for metal, diameter 1-13 mm, increasing at intervals of 0.5 mm in sheet metal box
- 1 set Spiral wood drills, diameter: 4, 6, 8, 10, 12 and 14 mm in box
- each 1 x Spiral wood drills, diameter: 14, 18 and 22 mm, length 300 mm
- 1 x SDS-plus flat chisel, length 250 mm
- 1 x Centre punch DIN 7250-5 x 150

Order no.	Weight kg
217920	5,1



Hammer drill and chipping hammer Bosch GBH 7-46 DE Professional

The most powerful hammer drill in its class has become even more powerful: powerful 1350 Watts with turbo power for 20% more power when chipping. Considerable power reserves for maximum removal and long service life due to robust metal components. Superior drilling progress when drilling in concrete in diameter range starting at 25 mm. Optimised hammer mechanism for even more penetrating power (up to 15 Joules when chipping).

Features:

- SDS max tool holder for safe and quick locking
- Extremely compact design, with switch integrated in housing
- Ergonomic handle with vibration damping
- Components that have been tried and tested millions of times such as SDS max holder, Constant Electronic, Vario-Lock, service display, overload clutch



made
in
Germany

Technical data:

Power consumption:	1350 Watts
Hole Ø in concrete:	Solid drills/annular crowns 45/150 mm
Nominal speed:	145 - 280 rpm
Number of impacts:	1375 - 2800 rpm
Impact energy:	13/15 Joules

Scope of delivery:

Drill grease, cleaning cloth, additional handle, case

Order no.

217910

Weight kg

8,2

Hammer drill and chipping hammers Bosch GBH 11 DE

Powerful universal hammer for quick drilling and chiselling. Top drilling performance (breakthrough in 60 seconds, 110 mm deep with Ø 55 mm) by means of optimised hammer mechanism and new high-performance motor. SDS max tool holder for safe and quick locking, compact torque transmission, with integrated dust protection. Constant electronic with adjuster wheel for preselectable speed, impact rate and strength. Variable chisel mounting in 12 angle positions. The service display indicates when carbon replacement is required in good time.

Features:

- SDS max tool holder for safe and quick locking
- Overload clutch
- Low-vibration hammer mechanism
- Shut-off carbons
- Variable additional handle
- Optimised dust sealing in the tool holder and new type of ventilation grille for long service life
- Top quality materials and components: fibre glass reinforced plastic, aluminium, precision parts made from steel



made
in
Germany

Technical data:

Power consumption:	1500 Watts
Hole Ø in concrete:	solid drills/annular crowns 45/150 mm
Nominal speed:	120 - 250 rpm
Impact energy:	5 - 18 Joules
Number of impacts:	1100 - 2250 rpm

Scope of delivery:

Drill grease, cleaning cloth, additional handle, case

Order no.

217915

Weight kg

11,1

Chisel SDS-max

With SDS-max holder for heavy drilling and demolition hammers.

Order no.	Models	Length mm	Weight g
280021	Flat chisel	400	770
280020	Pointed chisel	400	720

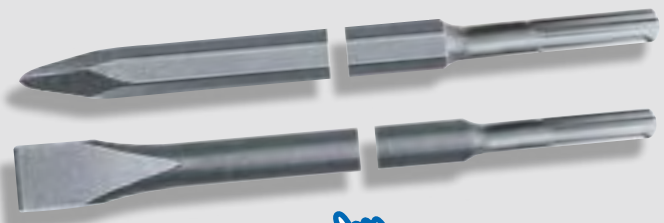

Other models
on request



Additional sizes
on request

Hammer drill SDS-max

Slimline spiral hammer drill with SDS-max holder for heavy hammer drills and demolition hammer drills.

- 4-cutter drilling head
- Double-threaded spiral for optimum bore dust removal

Order no.	Ø mm	Total/useful length mm	Weight g
280022	35	370/250	1060
280023	35	670/550	2020



Demolition hammer Bosch GSH 27

Electric chisel hammer for the heaviest of breaking and demolition work. Extremely robust design, for extremely long service life. Low-vibration during operation and idling due to balanced hammer mechanism and handles with recoil damping.

Tears down concrete ceilings and walls, foundations, road surfaces etc. Digs into tough and solid substances, crusted gravel and much more.

Features:

- Compressed air striking tools 1-1/8", can be used with collar
- Dust-tight tool holder
- Shut-off carbons
- Connection to any light socket, fuse protection 16 A or AC generators from 3 kVA
- Tool holder: 28 mm hexagon socket

Technical data:

Power consumption:	1900 Watts
Tool holder:	28 mm hexagon socket
Number of impacts:	1030 rpm
Impact energy:	60 joules

Scope of delivery:

Pin wrench W/F 5 mm and 6 mm

Order no.	Weight kg
217916	29,0

Angle grinder Bosch GWS 2000-23 JH "Fire Brigade"

The most frequently sold model in the fire brigade area. With 2000 W motor and stick handle. Weighs just 4.3 kg (without cable) and is extremely compact. The perfect device for maximum handiness and light weight. Equipped with 10 m H07RN-F 3 x 1.5 connecting cable and presswater-impermeable plug.

Features:

- Powerful 2000 W motor
- Double sealed ball bearing and the extremely robust gearbox ensure that the equipment has a long service life
- Armour-plated windings protect the motor from sharp grinding dust and provide a long service life
- Start-up current limitation and gentle start-up
- Tricontrol safety switch
- Light and compact for optimum handling
- Rotating gear head



exclusive

made
in
Germany

Technical data:

Power consumption:	2000 Watts
Disk diameter:	230 mm
Idle speed:	6500 rpm
Spindle thread:	M14
Max. cutting depth:	68.0 mm

Scope of delivery:

Safety hood, flange, clamping nut, two-hole key, additional handle

Order no.

211610

Weight kg

7,2

Cutting/grinding disk

German brand name make, suitable for all popular angle grinders.

Hole size 22 mm Ø.



made
in
Germany

Order no.	Application	for material	Ø mm	Weight g
280024	Cutting	Metal	115	100
280025	Cutting	Metal	180	200
280026	Cutting	Metal	230	300
280027	Cutting	Stone	115	100
280028	Cutting	Stone	180	200
280029	Cutting	Stone	230	300
280083	Cutting	Aluminium	115	100
280084	Cutting	Aluminium	180	200
280085	Cutting	Aluminium	230	300
280030	Grinding	Metal	115 x 6	200
280031	Grinding	Metal	180 x 6	500
280037	Grinding	Metal	230 x 6	800

Cutting disks 300 and 350 mm Ø

German brand name make, suitable for all popular cutting equipment. Hole size 20 mm Ø.

Order no.	Type	for material	Ø mm	Weight g
1 280032	Artificial resin	Stone	300	500
2 217921	Diamond	Stone	300	900
280033	Artificial resin	Metal	300	500
280034	Artificial resin	Aluminium	300	500
280081	Artificial resin	Asphalt	350	760
280082	Diamond	Stone	350	2000
280086	Artificial resin	Metal	350	840



made
in
Germany

Special diamond cutting disks Rescue Disc

Newly-developed diamond technology and top quality workmanship open up totally new usage areas for these special diamond cutting disks. The diamonds, which are attached to the carrier disk in a vacuum, will cut even the hardest material effortlessly with little wear.

The cutting disks are available in different diameters for all popular abrasive cutters.

Tests have shown that this disk is suitable for cutting the following materials:

iron and steel, aluminium, sandwich materials, plastic, rubber, glass, concrete/reinforced concrete, stone, asphalt. A disk change is therefore superfluous!



Order no.	Dimensions mm	Hole size mm	Weight g
280350	125	22	100
280355	230	22	600
280360	300	20	1300
280335	350	20	2000



Cordless jigsaw Bosch GSA 18 V-LI

Best cutting power in its class.
Up to 100 spruce beams (100 x 100 mm) cut to length with a single battery charge.

Features:

- Electronic Motor Protection (EMP) protects the motor from overloading and provides a long service life
- Easy handling: Quick and easy saw blade changes using new SDS mechanism
- Unique premium lithium ion technology for 400 % longer service life and unbeatable battery service life
- Electronic Cell Protection (ECP): Protects the battery from overloading, overheating and deep discharging
- 2-stage speed setting for different materials
- Ergonomically shaped handle with comfort zone in the soft-grip area for secure hold and non-tiring work
- Hyper-Charge: Due to quick charging the batteries are already after half of the charging time
- No memory effect: The battery can be charged at any time irrespective of the charge condition without damaging the cells

Technical data:

Battery voltage:	18 Volts
Battery capacity:	2.6 Ah
Idle speed:	2700 rpm
Stroke lengths:	28 mm

Scope of delivery:

quick charger, 2 x 2.6 Ah Li-Ion battery, saw blade for wood and metal, case

Order no.

217952

Weight kg

3,5



made
in
Germany

Cordless jigsaw Bosch GSA 36 V-LI

As powerful as a mains-operated saw: Up to 195 spruce beams (100 x 100 mm) cut to length with a single battery charge. Li-Ion technology for outstanding performance with extremely light weight.
Mobile powerhouse: The stroke length of 28 mm provides a maximum cutting depth of 250 mm.

Features:

- Electronic Motor Protection (EMP) protects the motor from overloading and provides a long service life
- Easy handling: Quick and easy saw blade changes using new SDS mechanism
- Practical: The innovative suspension device keeps the jigsaw ready to hand all all times
- Used for almost any material: e.g. wood, metal, stone
- Unique premium lithium ion technology for 400 % longer service life and unbeatable battery service life
- Electronic Cell Protection (ECP): protects the battery from overloading, overheating and deep discharge
- 2-stage speed setting for different materials
- Hyper-Charge: Quick charging means that the batteries are already 75 % charged after half of the total charging time
- No memory effect: Battery can be charged regardless of charge condition at any time without damaging the cells

Technical data:

Battery voltage:	36 Volts
Battery capacity:	2.6 Ah
Idle speed:	0 - 2400/3000 rpm
Stroke lengths:	28 mm

Scope of delivery:

Quick charger, 2 x 2.6 Ah Li-Ion battery, saw blade for wood and metal, case

Order no.

217951

Weight kg

4,2



made
in
Germany

Jigsaw Bosch GSA 1200 E

Ideal for cutting metal (tubes, profiles, steel plate). Many other applications in wood, plastic and construction materials when using the saw blades that are specially suited to these materials.

Features:

- Continuous electronic stroke rate control for material-compatible working
- Brute™ Drive system: patented drive system for long-term use, even under extreme load
- Patented Bosch SDS system for convenient and quick one-handed saw blade changes
- Rubberised housing for secure grip
- Adjustable stop (not tools required) for precise cutting depth adjustment and long-lasting saw blades

Technical data:

Power consumption: 1200 Watts
 Cutting capacity in wood: 250 mm
 Profile/tube cutting depth: 20 mm
 Idle stroke rate: 0 - 2800 rpm
 Saw, stroke length: 19 mm

Scope of delivery:

Saw blade for wood and metal, case



Brute™ Drive system



made in Germany

Order no. **217941**

Weight kg 3,7

Jigsaw blades

With different qualities for all applications and requirements, all makes are universally suitable for machinery from other manufacturers. Supplied in packs of 5.

Dönges industrial quality made in Germany. Extremely long service life, complies with DIN 14555-T3 (equipment vehicle loading).



made in Germany

Order no.	for material	Length mm	Tooth pitch mm	Weight g Pack
217950	Green wood etc.	230	8,5	220
217955	Wood and plastic	300	2,5	280
217960	Wood with nails	150	2,5	140
217965	Bi-metal, sheet metal etc.	200	1,8/2.5	130

Original BOSCH quality

Order no.	for material	Length mm	Tooth pitch mm	Weight g Pack
217956	Green wood etc.	240	8,5	220
217957	Wood and plastic	200	2,5	280
217958	Wood with nails	150	2,5	140
217959	Bi-metal, sheet metal etc.	150	1,8	130



Jigsaw Flex SKL 2902 VV

1200 Watt jigsaw with rotating handle.
The top model among the Flex Universal jigsaws.
With Softgrip rotating handle for areas that are difficult to access.

The decisive advantages:

- 1200-Watt high performance motor with additional pendulum stroke for rapid wood sawing work
- Rotating soft handle: the vibration destructor, rotates axially by 90° clockwise and 2 x 90° anticlockwise
- Flex dual-VV-electronics: for a constant stroke rate and soft start-up with acceleration switch
- Quick saw blade changes without tools
- Saw blade adjustment 0° and 180°, also for sawing overhead

Technical data:

Stroke rate: 0 - 2600 rpm
Stroke: 28 mm
Power consumption: 1200 Watts

Scope of delivery:

Including one piece of sawblades for plastics, wood and metal and case

Order no.
217930

Weight kg
4,0



Jigsaw Flex SKL 2903 VV "Tiger claw"

1200 Watt jigsaw with 3-D function joint.

The double-rotating jigsaw is impressive because of its extreme flexibility: The middle joint can be rotated by 180° and engages in 13 positions. The front joint can be axially rotated by 360° and engaged in 12 positions. This can even be done whilst sawing is in progress. Ideal in confined spaces.

The decisive advantages:

- 1200-Watt high performance motor with additional pendulum stroke for rapid wood sawing work
- Flex dual-VV-electronics: for a constant stroke rate and soft start-up with acceleration switch
- Quick saw blade changes without tools
- Saw blade adjustment 0° and 180°, also for sawing overhead
- Angle of saw support adjustable, also with 4 level settings

Technical data:

Stroke rate: 0 - 2900 rpm
Stroke: 29 mm
Power consumption: 1200 Watts

Scope of delivery:

Including one piece of sawblades for plastics, wood and metal and case

Order no.
217935

Weight kg
4,0



Laser distance meter DLE 70

The world's smallest laser distance meter is impressive because of its high precision and mobile phone-like size.

Features:

- Distance measurement up to 10 times quicker due to minimum and maximum area function
- Simple, accurate measurement of distances, areas and volumes
- Extreme accuracy due to the latest laser technology up to a range of 70 m
- Large number of practical functions such as indirect length measurement, continuous measurement, addition and subtraction function or memory
- Ideal device for any construction site, since it is protected from dust and water spray (IP54)
- Tripod holder for convenient use together with construction tripod
- Easy, intuitive operation with clear display
- Soft grip

Technical data:

Measuring range:	0.05 - 70 m
Typical measuring accuracy:	± 1.5 mm
Measuring time:	min.: 0.5 s; max.: 4 s
Laser class:	2
Laser diode:	635 nm, < 1mW
Power supply:	4 x 1.5 V LR03 (AAA)
Automatic shut-off:	5 min
Batteries:	4 x 1.5 V AAA/Micro/LR03



Suitable batteries on page 193

Scope of delivery:

protective bag, hand strap, batteries

Order no.	Dimensions mm	Weight g
217911	100 x 59 x 32	180



with integrated spirit level



Safety voltage tester

The special situation with regard to fire brigade operation often requires special tools. This voltage tester has been developed for testing potentially live cables, even under adverse conditions.

Its unique all-rubber housing completely encapsulates the measuring equipment and therefore provides optimum protection from impacts, water, dust and electric shock. This makes this voltage tester indestructible, safe and long-lived.

It also complies with the fire brigade standard DIN 14885 and has protection class IP65.

Features:

- All-rubber safety housing
- CAT IV - maximum safety from surge voltage
- Voltage testing without a battery
- Three display systems: Precision movement + LED + LCD indicator
- Measuring range up to 750 V

Order no.	Dimensions mm	Weight g
217310	274 x 75 x 47	460

made in Germany

exclusive **DOENGES**



JÄCKLE

specialist in plasma cutting systems for over twenty years.

The IP44 series has been consistently designed for the fire brigade and the rescue services right from the start, and therefore provides uncompromising top performance.

The devices are manufactured in Swabia, Germany with a great deal of attention to detail.

Operation is child's play - the equipment is ready to use immediately. The equipment is also extremely robust and maintenance-friendly. The equipment can be opened without losing IP44 classification, for example.

Jäckle has been a specialist in plasma cutting systems for more than twenty years. The experience from this practical work has flowed into this equipment, and is the guarantee of top quality.

Common features:

- Inverter technology: light weight, infinitely variable cutting current
- Any material can be cut without problems: steel, stainless steel, aluminium, brass, copper, etc.
- Protection class IP44 water spray protected (including burner, hose package etc.)
- In aluminium housing and stable aluminium tubular frame for transportation and protection
- Plasma gas: compressed air (also possible with breathing air cylinders)
- Complete with plasma burner (15 m hose) IP44 model, internal connection
- Temperature-controlled fan
- Power components cooled via air duct
- Simple single-button operation
- S-symbol approval



made
in
Germany

exclusive **DÖNGES**

The Plasma 65 IP44 complies with the latest equipment vehicle standard DIN 14555-3, but is also suitable for many other types of vehicle, of course.



The THW is already using 137 large Plasma 110 IP44 units. Metal up to 35 mm thick can be quickly and effortlessly cut.

Working with plasma units is extremely easy to learn. You do not have to use dangerous gas cylinders, as is the case with conventional gas cutters.

Practising with the equipment is also extremely low-cost, since nothing is worn or used up apart from a pair of electrodes (and a little electricity and compressed air).



Jäckle 65 IP44 plasma cutting device

The Plasma 65 IP44 was specially developed for the fire brigade and complies with DIN 14555-T3 (equipment vehicle loading).

Technical data:

Mains voltage:	400 V/16 A
Max. power consumption:	10.9 kVA
Separating cut:	up to 20 mm
Compressed air supply:	5.5 bar/160 l/min.

Scope of delivery:

Jäckle Plasma 65 IP44, 15 m hose package with CUT 70 burner IP44, 15 m ground cable, pressure reducer 200/300 bar, 10 m compressed air connecting hose with quick-release coupling, 15 m mains connecting cable with DW plug, two pairs of safety goggles.

Order no.	Dimensions mm	Weight kg
217700	680 x 260 x 525	26,0



made in Germany

exclusive **DOENGES**

Plasma 110 IP44

The Plasma 110 IP44 was originally developed for the THW. 137 of the originally developed devices were purchased.

Technical data:

Mains voltage:	400 V/32 A
Max. power consumption:	19.8 kVA
Separating cut:	up to 35 mm
Compressed air supply:	5.5 bar/180 l/min.

Scope of delivery:

Jäckle Plasma 110 IP44, 15 m hose package with CUT 110 burner IP44, 15 m ground cable, pressure reducer 200/300 bar, 10 m compressed air connecting hose with quick-release coupling, 15 m mains connecting cable with DW plug, two pairs of safety goggles.

Order no.	Dimensions mm	Weight kg
217705	795 x 320 x 595	38,0

Set of spare parts and consumables for Jäckle plasma cutting devices

In order to keep the plasma cutting device ready for use at any time, we have put together useful sets of spare parts and consumables for the different plasma cutting devices. The sets are supplied in a sturdy plastic case and contain all of the parts that wear during use or become damaged under harsh conditions.

Contents:

- 2 x protective caps
- 5 x spacer springs
- 2 x spiral rings
- 2 x insulators
- 2 x electrode/nozzle sets, short

Order no.	for Jäckle model	Weight g
217798	65 IP44	540
217799	110 IP44	650



made in Germany

exclusive **DOENGES**

Accessories/spare parts for Jäckle

The use of these original accessories is strictly necessary in order to keep the equipment operating in the best possible way. The electrode/nozzle sets each contain five electrodes and nozzles.



made in Germany

Order no.	for device	Item	pu/pc.	Weight g
217710	65 IP44	15 m burner package compl.	1	4900
217715	65 IP44	Safety cap	1	40
217720	65 IP44	Spacer spring	1	20
217725	65 IP44	Fibre nozzle	1	5
217730	65 IP44	Crown-type nozzle	1	5
217735	65 IP44	Electrode/nozzle set, short	5/5	5
217740	65 IP44	Electrode/nozzle set, long	5/5	5
217745	65 IP44	Spiral ring	1	20
217750	65 IP44	Insulator	1	5
217755	110 IP44	15 m burner package compl.	1	5600
217760	110 IP44	Safety cap	1	40
217765	110 IP44	Spacer spring	1	20
217770	110 IP44	Fibre nozzle	1	5
217775	110 IP44	Crown-type nozzle	1	5
217780	110 IP44	Electrode/nozzle set, short	5/5	5
217785	110 IP44	Electrode/nozzle set, long	5/5	5
217790	110 IP44	Spiral ring	1	20
217795	110 IP44	Insulator	1	5
217800	both	Pressure reducer 200/300 bar	1	600

Dönges cutting torch

Portable cutting torch compliant with expired DIN 14800. For quick cutting of iron, steel and aluminium, even extremely thick material (> 30 mm). Well-tries unit for use in situations where no power supply is available.

Scope of delivery:

Complete set with filled acetylene and oxygen cylinders, pressure reducer, frame with leather strap and cellular rubber padding, usage location document, cutting torch for use on materials up to 100 mm thick, hose set and all of the necessary tools.

Order no.	Item	Weight kg
214450	Set, complete	36,0
214451	Acetylene cylinder 5 l (filled)	12,0
214452	Oxygen cylinder 5 l (filled)	12,0

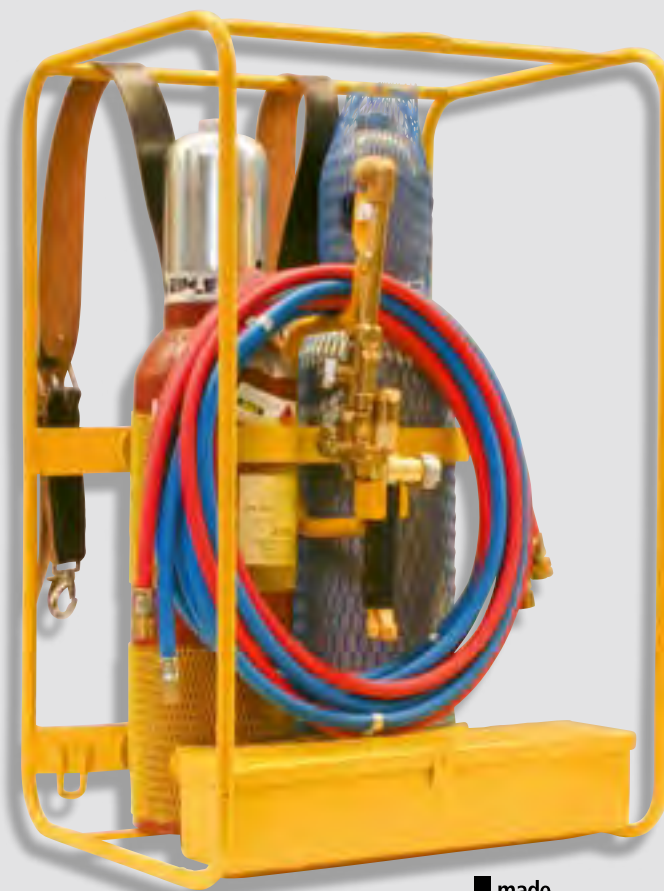

made
in
Germany

DÖNGES
exclusive



Vehicle movement device

The GOJAK manoeuvring aid is the optimum tool for quickly moving vehicles that can no longer be moved under their own power or are hindering rescue work without using a great deal of force.

The patented lifting system is attached to the vehicle within seconds, and the vehicle can be effortlessly lifted with a few operations of the foot pedal. Once all four wheels have been raised from the ground, the vehicle can be moved by a single person.

Two versions with different lifting capacities are available. In order to be equipped for any eventuality, it is advisable to have a set of four GOJAKs. This results in a total lifting capacity of 2.2 tons with the GOJAK 5000 and even 2.6 tons with the GOJAK 6200. This is sufficient to even lift all-terrain vehicles and vans. The GOJAK 6200 is also available in two versions for the left (L) and right (R) sides of the vehicle.

Technical data	GOJAK 5000	GOJAK 6200L/R
Capacity:	550 kg	650 kg
Wheel width max.:	22.5 cm	33 cm

Order no.	Model	Dimensions mm	Weight kg
221105	GOJAK 5000	600 x 580 x 150	13,7
221112	GOJAK 6200L	650 x 600 x 160	17,5
1 221114	GOJAK 6200R	650 x 600 x 160	17,5



Can be easily folded up



Folded up just 1890 x 960 x 360 mm. Easy to carry by two people. The platform is secured with two tension straps.

Can be levelled using the four spindle feet by up to 400 mm.

Plettac rescue platform

Platform for rescuing people from lorries, trains etc. Extremely sturdy design, all made from aluminium. The folding mechanism means that the frame of the platform is set up in seconds. The aluminium floor grates are inserted and the removable handrail attached. This makes the maximum erection time about one to two minutes.

The supplied spindle feet allow the height of the entire platform to be adjusted or adapted to different levels. The non-slip floor grates have six height settings (25 cm intervals), maximum working height approx. 150 cm, working are dimensions approx. 1750 x 700 mm. The all-aluminium version keeps the weight down: approx. 63 kg.

The work platform complies with the requirements of DIN 14555-3, rescue vehicle loading.

Features:

- All-aluminium structure
- Folding mechanism for quick setup
- Non-slip floor grates
- Spindle feet all round, height adjustable by about 400 mm
- Removable handrail
- Packing size approx. 1890 x 960 x 360 mm
- Optionally available: Rollers for use on railway tracks

Order no.	Item	Dimensions mm, packed	Weight kg
221150	Working platform	1890 x 960 x 360	63,0
221155	Railway track rollers	1792 x 1435 x 200	48,5

Telescopic ladder

The practical, flexible and extremely compact solution for working heights of up to 4.40 m.

This patented ladder can be conveniently pushed together and therefore easily transported, even if little space is available.

Features:

- TÜV tested in acc. with GS and EN 131
- Steps and sides made from extruded aluminium profiles
- Sides anodised and therefore abrasion-proof
- Convenient height adjusting facility on guide bushes and sliding bushes
- Can be extended rung by rung up to a ladder length of 3.30 m (4.40 m working height)
- Just 78 cm long when pushed together

Technical data:

Ladder length: max. 3.3 m
Working height: max. 4.4 m

Order no.

215105

Weight kg

9,5



extended

pushed together



Multipurpose ladder with 4 x 3 rungs

This ladder can be used as both a simple ladder or step ladder, as a work trestle or simple ladder with support. The ladder can be stowed in almost any vehicle when it is folded up. Adjustment takes place using six automatic steel hinges. The feet of the ladder are equipped with rubber shoes.

The ladder is GS tested and complies with EN 131.

Technical data:

Rungs: 4 x 3
Length max.: 3.61 m
Max. working height: 4.51 m
Height of step ladder: 1.80 m
Folded up: 0.98 x 0.36 x 0.26 m
Load-bearing capacity: 150 kg

Order no.

257600

Weight kg

13,5



Experienced teams require less than a minute for a windscreen.



Glas-Master is a trade mark belonging to **Wehr Engineering** from Indianapolis, USA.

The patented Glas-Master has been manufactured and improved here for many years.

The device has made a triumphant march over the entire world, and is standard equipment with the majority of fire brigades around the globe.

Do not confuse the Glas-Master with the many cheap copies that now exist - only the original provides the perfect sawblade geometry, the operating safety and an extremely long service life.

i
The original - not authentic without the "Made in USA" sticker. Take care - there are many copies of the Glas-Master.

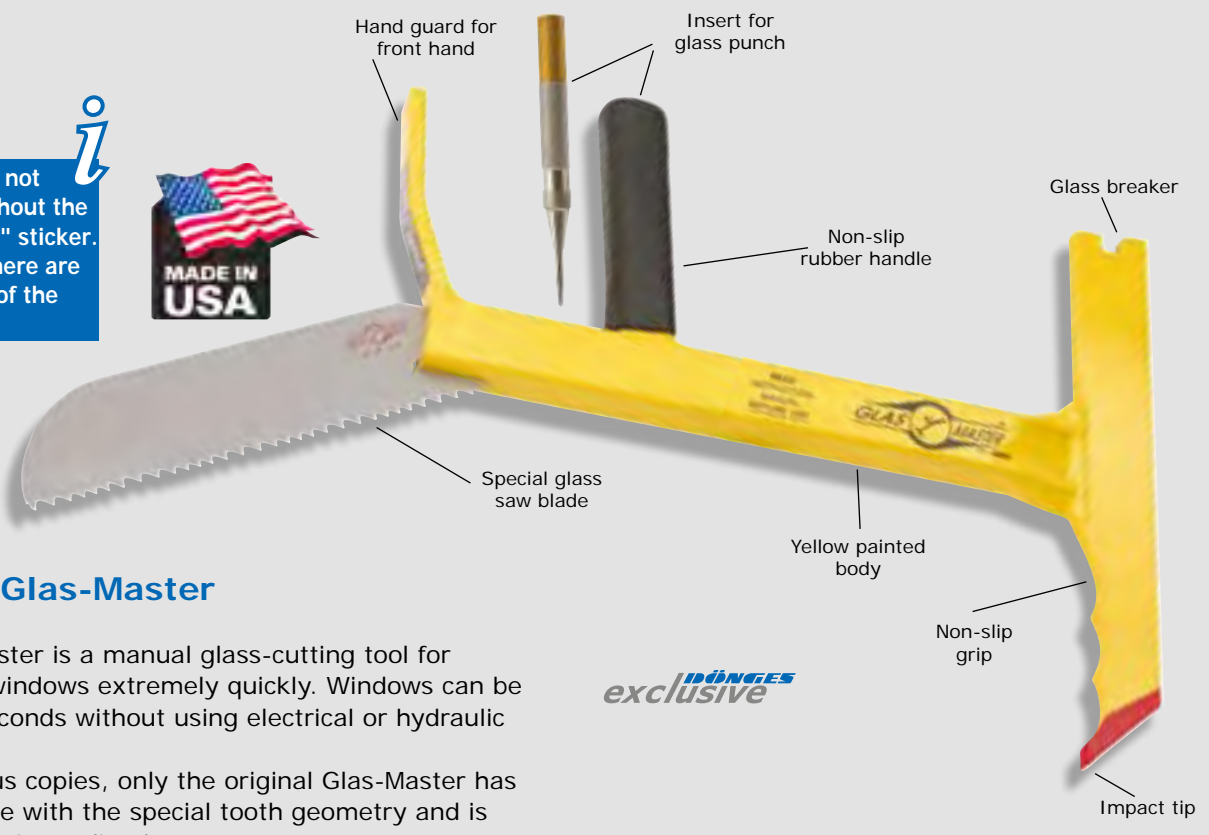

Original Glas-Master

The Glas-Master is a manual glass-cutting tool for cutting out windows extremely quickly. Windows can be cut out in seconds without using electrical or hydraulic equipment.

Unlike various copies, only the original Glas-Master has the saw blade with the special tooth geometry and is ready for use immediately.

The automatic spring centre punch is kept in the rubber-coated handle of the Glas-Master, with which side and rear windows can be opened. In order to use the punch, it is turned round and placed on the window. When a certain amount of pressure is applied, the punch is activated and shatters the safety glass.

- Other features:**
- Sturdy, varnished tubular steel body
 - Replaceable special saw blade
 - Hand guard
 - Non-slip, soft rubber handle for front hand
 - Two screw-on wall and vehicle brackets

Order no.	Item	Length mm	Weight g
212470	Original Glas-Master	425	1360
212475	Spare saw blade	165	200



Easy, safe breaking of side windows with the glass breaker.

DOENGES
exclusive

Glas-Master glass management set

A toolcase with which the emergency services have everything ready to hand when they arrive at the scene of a traffic accident for obtaining initial access to the victim through the front, side or rear window.

The sturdy plastic case contains partitioning made from industrial Plastazote, which reliably secures the tools in place and keeps things organised. The set is recommended for patient-oriented rescue work.

Contents:

- 1 x Original Glas-Master with special saw blade
- 1 x Original Glas-Master rescue knife PRT II
- 1 x Spring centre punch
- 1 x Safety goggles
- 1 x Clip lifter
- 3 x Dust masks
- 1 x Adhesive tape dispenser
- 1 x Textile adhesive tape for masking the side windows and easy lifting out of the windscreen
- 2 x Foil for covering the accident victim during the work

Order no.	Dimensions mm	Weight g
212471	480 x 460 x 140	4200



Veribor suction lifter

Sturdy two-piece suction lifter with plastic body for moving panes of glass. Also ideal as a supplement to the Glas-Master or the Glas-Master glass management set.

Order no.	Length mm	Load-bearing capacity kg	Weight g
212474	310	80	580



made
in
Germany





Special glass punch

Hardened, automatic special spring centre punch for opening side or rear windows. Single-handed operation: just position and push!

The punch can be kept in the handle of the Glas-Master or used as an independent tool.

Made from brass with hardened steel tip.

Order no.	Length mm	Weight g
211314	130	60

Spring glass punch

Simple but extremely effective tool for destroying the side and rear windows of accident vehicles. The centre punch is placed on the window and the spring is then tensioned. As soon as the spring is released, the end of the centre punch strikes the tip - and the window shatters.

Order no.	Length mm	Weight g
211315	120	70



Lifehammer-I rescue hammer

In the event of an accident it may not be possible to open the seat belt buckles and the window and doors, or they may become jammed. The Lifehammer can solve this problem, and every car should therefore have one.

The in-vehicle mounting device can be screwed on or pinned to the carpet of the car.

Features:

- Shatters side windows
- Cuts seat belts
- With in-vehicle mounting device

Order no.	Length mm	Weight g
212476	175	100





DÖNGES
exclusive



Leather reinforcement on the inside at critical points

Strong magnets

Sturdy nylon fabric

Economy safety blanket set

This set protects rescue services and accident victims from injuries on sharp edges and glass splinters after cutting off the roof of a car.

The blankets consist of leather-reinforced and extremely carefully manufactured black nylon fabric. All parts have a reflective strip round the edges. The blankets stick firmly to the sheet metal using incorporated magnets.

Set A:

5-piece for one half of the car, consisting of:

- 1 x Large safety blanket for windscreen/rear window 144 x 37 cm with eight strong magnets
- 2 x Safety blankets for side windows 57 x 37 cm with six strong magnets
- 2 x Spar protector 35 x 35 cm

Set B:

10-piece for an entire car, consisting of:

- 2 x Large safety blankets for windscreen/rear window 144 x 37 cm with 8 strong magnets
- 4 x Safety blankets for side windows 57 x 37 cm with six strong magnets
- 4 x Spar protector 35 x 35 cm

Order no.	Model	Weight kg
215150	5-piece set	2,7
215155	10-piece set	5,4

Dönges safety blanket set

This nine-piece safety blanket set consists of extremely strong materials for use in harsh conditions by fire brigades and rescue services. The safety blankets consist of washable nylon fabric on the outside and extremely tough, tear-resistant nylon/polyester mixed fabric on the inside. The deployment tarpaulins and the carry bag are made from sturdy tarpaulin material, which is also easy to wash.



DÖNGES
exclusive

Scope of delivery:

- 1 x Safety blanket for windcreens and rear window, 160 x 60 cm, extremely tear-resistant nylon fabric, with six strong magnets
- 2 x Safety blankets for side windows, 65 x 65 cm, extremely tear-resistant nylon fabric, with four strong magnets
- 4 x Spar protectors, 28 x 43 cm, extremely tear-resistant nylon fabric, with Hook & Loop tape for secure attachment
- 1 x Deployment tarpaulin, 120 x 250 cm, sturdy tarpaulin material, with overprint "Material provision cover"
- 1 x Carry bag, sturdy tarpaulin material, separate, labelled compartments with Hook & Loop fastener for safety blankets and deployment tarpaulin, Pack size 70 x 50 x 15 cm

Order no.	Weight kg
250000	7,2

Dönges airbag protection system A.S.S.

In the event of traffic accidents, the victim and the rescuer should always be protected from unintentional airbag activation.

For this purpose, Dönges has collaborated with Wadra to develop an improved airbag protection system. This system is the combination of absolute safety and user-friendliness.

Wadra has many years of experience (since 1998) in sewing these systems. The protection systems are manufactured in the Dortmund factory, and of course have **TÜV/GS certification**.

The driver airbag systems are available in three different sizes for cars, vans and lorries. We can also supply a front passenger airbag system.

The driver system consists of six tested seat belt straps and a central plate, which contains the energy of the airbag and diverts it sideways. The front passenger system can be put on with the roof removed or intact.

The driver system can be put on within a few seconds with an appropriate amount of practice. This phase is safe for the rescuer due to the fact that the A.S.S. can be placed over the steering wheel from the side and automatically centres itself when it is tightened.

The front passenger system can also be installed within a minute with a little practice.

Unlike systems that are made from metal, there is no risk of injury if the airbag deploys whilst the system is being fitted. Metal systems are therefore banned in the USA, for example.

The decisive advantages of the **DÖNGES A.S.S. airbag protection system**:

- Extremely versatile and lightweight system for any application
- Colour codes for the different sizes on the base plate itself
- Short instructions with understandable pictographs on the cover plate of each A.S.S.
- All sets come in a practical carrying case
- **TÜV/GS** tested quality.

1, 2, 3 - the system is put on in just a few seconds:

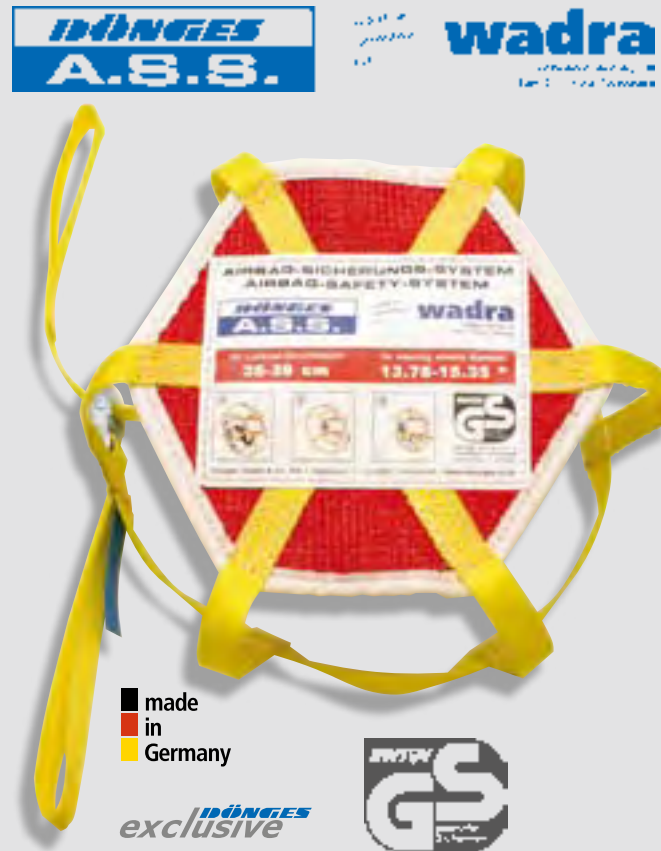
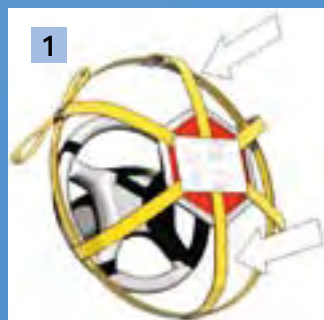

Complete set, driver side Car/van/lorry

You are equipped for any vehicle size with this set.

Supplied in sturdy plastic case.

- For steering wheel diameters of 35-39 cm, 40-45 cm and 43-50 cm

Scope of delivery:

Car airbag protection, van airbag protection, lorry airbag protection, operating instructions, case

Order no.	Case dimensions mm	Weight kg
218400	395 x 295 x 106	2,1



made
in
Germany

DÖNGES
exclusive

Drivers side set, car/van

Supplied in sturdy plastic case.

- For steering wheel diameters of 35-39 cm and 40-45 cm

Scope of delivery:

Car airbag protection, van airbag protection, operating instructions, case

Order no.	Case dimensions mm	Weight kg
218410	395 x 295 x 106	1,7

made
in
Germany

DÖNGES
exclusive

Driver side, lorry

Supplied in sturdy plastic case.

- For steering wheel diameter of 43-50 cm

Scope of delivery:

Lorry airbag protection, operating instructions, case

Order no.	Case dimensions mm	Weight kg
218420	395 x 295 x 106	1,2

made
in
Germany

DÖNGES
exclusive

Front passenger side

The system can be quickly put on using the five provided tension straps with the roof cut off and also with the vehicle intact (in about one minute).

Supplied in sturdy plastic case.

Scope of delivery:

Front passenger airbag protection, five tension straps, operating instructions, case

Order no.	Case dimensions mm	Weight kg
218430	395 x 295 x 106	4,3

made
in
Germany

DÖNGES
exclusive



wadra

Intelligent solutions for
Rope & Lifting Technology

Wadra has been manufacturing wire cables, stops, load securing systems and multipurpose hoists at its Dortmund site since 1933.

Wadra multipurpose hoists have many advantages compared to other equipment:

- Slimline design
- Housing made from top quality cast aluminium impact resistant
- Little force required
- Parallel pairs of clamping jaws, therefore less surface pressure, superior clamping technology
- Cable guidance - due to forced opening and closing of the clamping jaws, the cable is easy to insert.
- Clamping jaws made from drawn material - no stocking of spare parts required, since there is hardly any wear
- Shearing pins can be replaced in any situation
- BG tested
- 5 -year warranty in acc. with VDMA

Tools



It's your decision!
Two makes to choose from –
Wadra or Greifzug

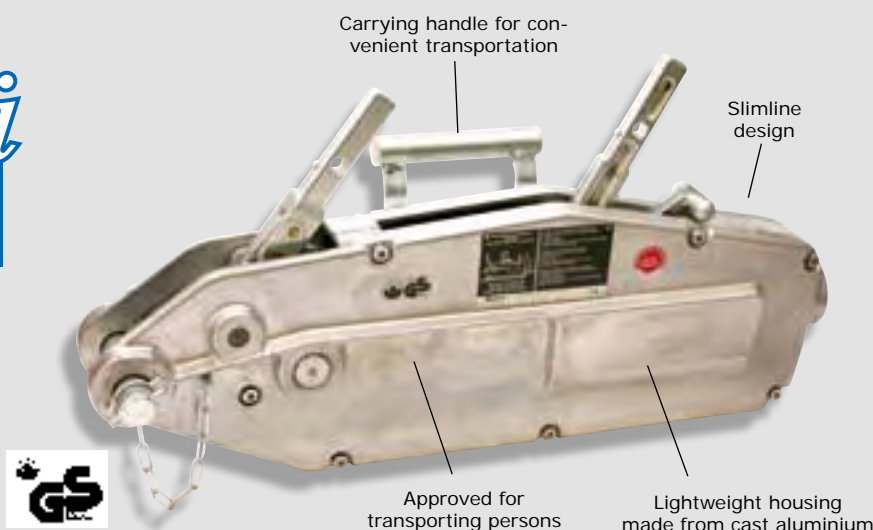

made
in
Germany

Greifzug GmbH

Greifzug is synonymous with multipurpose hoists in the fire brigade area. The T 516 D and T 532 D hoists are surely the most widely used cables in the German fire service.

Greifzug multipurpose hoists are characterised by having the following advantages:

- Unlimited cable length
- Can be used in any situation or direction
- Jolt-free working to the nearest millimetre
- Compact, handy design
- Safety factor 5
- Long service life
- Approved by the employer's liability insurance association



made
in
Germany

Multipurpose hoist DIN 14800-MZ 16

Newly designed set in acc. with DIN 14800-5:2005-02 with tensile strength of 16 kN.

Box 1:

- 1 x Dönges Firebox® made by Zarges, compliant with DIN 14880-1-LM (600 x 400 x 220 mm), with partitioning and stickers
- 1 x Multipurpose hoist MZ 16
- 1 x Levering tube
- 2 x Spare shearing pins

Box 2:

- 1 x Dönges Firebox® made by Zarges, compliant with DIN 14880-1-LM (600 x 400 x 220 mm)
- 1 x Guide pulley, hinged, single-pulley, for tensile strength of 32 kN
- 2 x Sling compliant with DIN EN 1492-2 made from Polyester, load-bearing capacity 40 kN, useful length 2 m
- 1 x Sling compliant with DIN EN 1492-2 made from Polyester, load-bearing capacity 40 kN, useful length 4 m
- 3 x Shackle A 4 DIN 82101 - tZn 600

Supplied separately:

- 1 x Cable, 11.5 mm Ø, 30 m long, with lifting hook, on reel

Optionally available:

- 1 x Ground anchor size 1 with 8 pegs
- 1 x Crowbar DIN 14853-1500
- 1 x Timber



Order no.	Item	Make	Weight kg
217410	Set, complete DIN 14800-MZ 16	Greifzug	56,3
217415	Set, complete DIN 14800-MZ 16	Wadra	58,5

Individual contents:

Order no.	Item	Make	Weight kg
214045	Box DIN 14880-1-LM-5.1 empty	Dönges	6,3
214050	Box DIN 14880-1-LM-5.2 empty	Dönges	6,3
214212	Hoist MZ 16 incl. lever tube	Greifzug	13,0
217420	Hoist MZ 16 incl. lever tube	Wadra	13,4
214214	Spare lever tube	Greifzug	0,9
217425	Spare lever tube	Wadra	1,5

Order no.	Item	Make	Weight kg
214220	Spare shear pin	Greifzug	0,1
217430	Spare shear pin	Wadra	0,1
214228	Guide pulley 32 kN	Dönges	1,3
280012	Sling 40 kN, 2 m	Dönges	1,7
280013	Sling 40 kN, 4 m	Dönges	3,2
212947	Shackle DIN 82101-A4	Dönges	2,5
217435	Cable on reel, Ø 11.5 mm, 30 m	Greifzug	15,4
217440	Cable on reel, Ø 11.5 mm, 30 m	Wadra	17,2
214224	Ground anchor, size 1 with pegs	Dönges	12,0
210320	Crowbar DIN 14853-1500	Dönges	8,0
212948	Timber	Dönges	1,0

Multipurpose hoist DIN 14800-MZ 32

Newly designed set in acc. with DIN 14800-5:2005-02 with tensile strength of 32 kN.

Box 1:

- 1 x Dönges Firebox® made by Zarges, compliant with DIN 14880-6-LM devoid of dividers, with label
- 1 x Multipurpose hoist MZ 32
- 1 x Levering tube
- 1 x Spare shearing pins
- 1 x Guide pulley, hinged, single roller, for tensile strength of 64 kN

Supplied separately:

- 1 x Cable, 16 mm Ø, 30 m long, with lifting hook, on drum reel
- 1 x Ground anchor size 2 with 12 pegs

Optionally available:

- 1 x Crowbar DIN 14853-1500
- 1 x Piece of timber



Either Wadra or Greifzug



made in Germany

exclusive DÖNGES



Order no.	Item	Make	Weight kg
217500	Set, complete DIN 14800-MZ 32	Greifzug	93,0
217505	Set, complete DIN 14800-MZ 32	Wadra	93,9

Individual contents:

Order no.	Item	Make	Weight kg
214055	Box DIN 14880-6-LM-5 empty	Dönges	7,9
214252	Hoist MZ 32 incl. lever tube	Greifzug	22,0
217510	Hoist MZ 32 incl. lever tube	Wadra	22,9
214214	Spare lever tube	Greifzug	0,9
217425	Spare lever tube	Wadra	1,5
214264	Spare shear pin	Greifzug	0,1
217515	Spare shear pin	Wadra	0,1
214270	Guide pulley 64 kN	Dönges	4,8
214266	Cable on reel, Ø 16 mm, 30 m	Greifzug	40,2
217521	Cable on reel, Ø 16 mm, 30 m	Wadra	40,2
214268	Ground anchor, size 2 with pegs	Dönges	18,0
210320	Crowbar DIN 14853-1500	Dönges	8,0
212948	Timber	Dönges	1,0

Guide pulley

These lightweight yet extremely sturdy guide pulleys are the ideal addition to the multipurpose hoist, or for cable winches. Since these guide pulleys can be opened, the cable is extremely easy to insert.

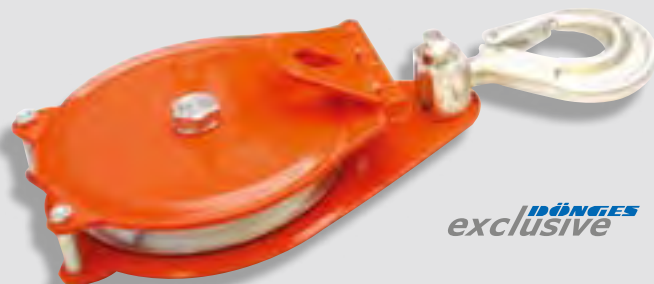

Advantages:

- Light weight
- Opens up
- Cable easy to insert
- High tensile strength
- Extremely good price/performance ratio

Order no.	Dimensions mm	Tensile force max. kN	for hoist kN	Weight kg
214228	275 x 220 x 55	32	16	1,3
214270	310 x 260 x 65	64	32	4,8
214271	400 x 310 x 85	100	50	11,3

Edge rider

For multipurpose hoist cables. With three rotating guide pulleys. For cable strength of up to 50 kN and cable diameter of max. 16 mm. With carrying handle. Galvanised steel.

Order no.	Dimensions mm	Weight kg
217532	250 x 240 x 170	6,2



DÖNGES
exclusive

Slings

Compliant with DIN EN 1492-2, Polyester, quality tested, with colour coding in acc. with EN.

Order no.	Load capacity t (single direct)	Useful length m (single)	Colour code	Weight kg
280003	1	1	violet	1,0
280004	1	1.5	violet	1,2
280014	1	2	violet	1,5
280015	2	1.5	green	1,0
280016	2	2	green	1,2

Order no.	Load capacity t (single direct)	Useful length m (single)	Colour code	Weight kg
280017	2	3	green	1,8
280018	3	2	yellow	1,4
280019	3	3	yellow	2,1
280035	3	4	yellow	2,8
280012	4	2	grey	1,7
280013	4	4	grey	3,2
217600	8	4	blue	4,2
212727	10	3	-	5,0
212725	10	5	-	6,5



Edge protector for slings

This edge protector can be easily fitted to almost any sling using the Hook & Loop fastener. It protects the sling from damage caused by sharp edges or rough surfaces.

Order no.	Dimensions mm	Weight kg
212719	250 x 240 x 170	0,6

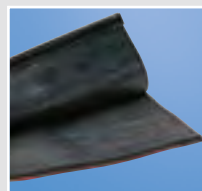

made
in
Germany

DÖNGES
exclusive



Stop chain

Single strand with shortening claws and safety lifting hook.

Chain in special quality. Nominal chain thickness 13 mm. Load capacity >6,500 kg. Useful length 4 m.

Order no.	Weight kg
212728	22,4

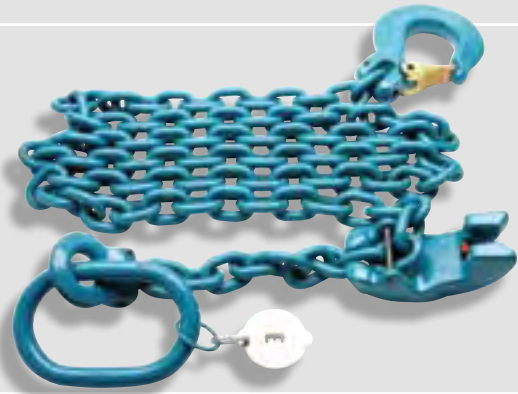

made
in
Germany

exclusive **DÖNGES**

Wooden shapes in Firebox® (RW)

Wooden shapes in acc. with DIN 14555-3 (equipment vehicle standard), stored in three **Dönges Firebox® baskets made by Zarges** in acc. with DIN 14880-1-LM-O-G, 600 x 400 x 220 mm.

Contents:

Basket no. 1:

- 4 x Wedges, 75 x 95 x 350 mm, unplaned, made from hard wood
- 16 x Wedges, 35 x 95 x 350 mm, unplaned, made from hard wood,
- 6 x Beech plywood board 50 x 200 x 350 mm, glued and watertight, with 3 mm bevel

Basket no. 2 and basket no. 3,

each:

- 8 x Pieces of timber, 120 x 88 x 500 mm, made from glued laminated wood (coniferous wood), glued and watertight, 3 mm bevel at edges, with carrying loop made from polyester rope with diameter of 10 mm

Order no.	Length x Width x Height mm	Weight kg
217366	600 x 400 x 270	41,7

The open baskets with perforated sides ensure that the wooden supports are ventilated even if they have to be stored in a damp condition after use.

Wooden shapes in Firebox® (HLF)

Wooden shapes in acc. with DIN 14530-11, stored in **Dönges Firebox® basket made by Zarges** in acc. with DIN 14880-1-LM-O-G, 600 x 400 x 220 mm.

Contents:

- 6 x Wedges, 75 x 95 x 350 mm, unplaned, made from hard wood
- 2 x Wedges, 35 x 95 x 350 mm, unplaned, made from hard wood
- 2 x Beech plywood board 50 x 200 x 350 mm glued watertight, with 3 mm bevel
- 4 x Pieces of timber, 120 x 88 x 500 mm, made from glued laminated wood (coniferous wood), glued and watertight, 3 mm bevel at edges, with carrying loop made from polyester rope

Order no.	Length x Width x Height mm	Weight kg
217368	600 x 400 x 220	23,7

made
in
Germany



exclusive **DÖNGES**

EGS wooden support set

The EGS scaffolding system has already proven itself many times during THW operations. Bracing supports, support towers, strut bracing and intermittent horizontal, vertical or angled force take-off can be quickly erected without a crane and with defined statics, even in difficult situations and without putting strain on unstable structures.

To go with the EGS scaffolding system, THW volunteers developed a wooden support set that is supplementary to the scaffolding system and provides additional support options.

Of course, the EGS wooden support set is not just a valuable companion to the THW during operations, but can also be used for many different support tasks.

During the different operational scenarios, wooden supports are needed to adapt to slopes, to secure loads, to distribute force, to stabilise vehicles etc.



Contents:

- 12 x Blocks, 100 x 120 x 500 mm
- 4 x Wedges, 100 x 120 x 450 mm
- 4 x Wedges, 50 x 120 x 450 mm
- 2 x Stepped blocks, 400 x 120 x 600 mm
- 4 x Plank sections, 240 x 50 x 500 mm
- 2 x Planks, 240 x 500 x 1500 mm
- 1 x Poker Ø 8 x 900 mm

Order no.	Weight kg
217664	93

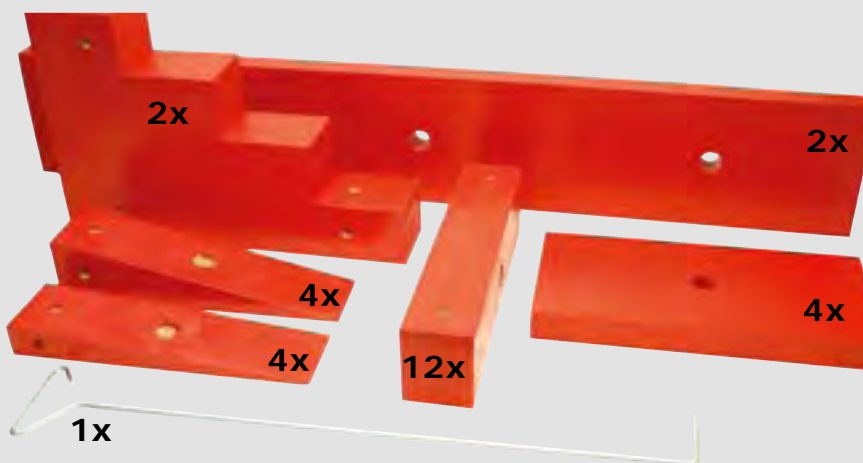

Timber

Compliant with DIN 21321.

Order no.	Width x Height x Length mm	Weight kg
217670	120 x 160 x 2000	7,0



made in Germany

exclusive DÖNGES

made in Germany

exclusive DÖNGES

Plank

Compliant with DIN 4071, with steel brackets, unplanned.

Order no.	Width x Height x Length mm	Weight kg
217665	220 x 48 x 2000	11,0

Transport roller

For putting beneath and moving even extremely heavy loads. Made from hot-galvanised tubular steel wall thickness 5 mm,

Order no.	Ø x Length mm	Weight kg
217660	80 x 1000	9,1

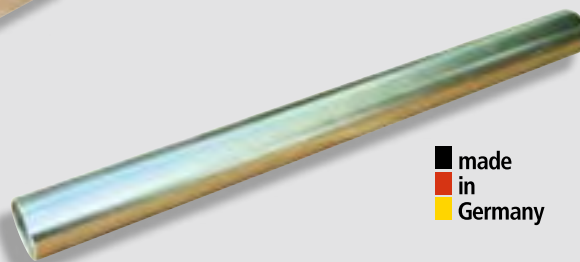

Usage options:

Drive-over ramp for cars, lorries and other vehicles (kerbs, railway crossings, pavements, thresholds etc.).

Drive-over ramp for the private sector. (cellar thresholds, wheelchair access, stairs etc).



Supplied without crate

**All-rubber drive-over ramp Turtle**

The new TURTLE drive-over ramp is extremely robust and resistant. The knobs that are fitted as standard prevent the individual ramps from falling apart when they are assembled. With two reflective strips for optimum visual detection during the day and at night. The all-rubber drive-over ramps are assembled in seconds, weatherproof and rot-proof.

Technical data:

Length:	330 mm
Wide ramp:	300 mm per section
Width including knobs:	368 mm per section
Height:	95 mm
Material:	All-rubber
Load capacity:	30 t

Order no.	Weight kg
211719	4,8

**Drive-over plank DIN 14854**

Made from hard wood, with bevelled corners and galvanised metal protection, two hand recesses on the underside for carrying.

Order no.	Width x Height x Length mm	Weight kg
211720	1000 x 400 x 50	10,5

Sand ladder

Made from aluminium, for driving on loose soil or for extracting a stuck vehicle. Also perfect for ice, snow and mud.

Well-known from the expedition and rally area, the sand plate also does a good job in the fire service. The hooks on the sides allow several plates to be assembled into a solid unit.

Complies with requirements of DIN 14555-T3 (equipment vehicle loading).

Order no.	Length x Width mm	Weight kg
218080	1500 x 400	4,0

made
in
Germany

exclusive





Steel winch DIN 7355

With lifting housing and self-locking safety crank, with folding handle. Housing painted in blue.

Technical data:

Lifting height: 350 mm
Structural height: 725 mm

Order no.	Lifting force t	Weight kg
214410	1,5	13,0
214415	3	20,0
214420	5	27,0
214425	10	29,0

made
in
Germany



Channel brace DIN 4124

With approval from the civil engineering employer's liability insurance association. With spike plate and nail hole. Permitted load as per table shown below, continuously adjustable, with permanent corrosion protection.

Features:

- Length continuously adjustable over 30 cm
- Steel tube spindle Ø 32 mm
- Non-sensitive to soiling or damage due to hardened thread



made
in
Germany

Order no.	Adjusting range mm	Perm. load kN	Weight kg
217680	600-900	36-29	4,0
217685	800-1100	34-29	4,6
217690	1100-1400	29-23	5,5

Quick-Lift support

Special support made from galvanised steel with patented, infinitely variable locking mechanism. Adjusted extremely quickly, permissible load capacity 55 kN, for use in vertical or horizontal position.

The Quick-Lift support is made from St 37 steel. The inner tube is self-locking due to the lifting shaft that runs in the angled aperture. The greater the pressure, the greater the self-locking effect until full static transition from the inner tube to the outer tube.

The opposing, tightened eccentric shaft presses the corrugated steel block against the inner tube and therefore provides a reliable "safety backup". The eccentric of the support is released. This support is used with the lifting element facing downwards. The operator places both feet on the support plate and pulls out the support. The support can then be unscrewed over the lifting element and/or clamped using the eccentric.

Features:

- Maximum load capacity 55 kN
- Quick installation and clamping
- Continuously adjustable
- Galvanised and maintenance free
- Reliably guided lifting shaft movement
- Locking eccentric shaft
- Handy
- Can be adjusted and pre-tensioned to the nearest millimetre.
- Tremendous load-bearing capacity
- Flexible behaviour proven during endurance testing

Order no.	Extension length mm	Weight kg
214310	300-500	5,5
214315	500-850	6,0
214320	600-1000	9,0
214325	900-1600	12,0
214330	1000-1750	13,5
214335	1700-3100	18,0
214340	2500-4000	22,0
214345	Operating lever (spare)	0,4
214346	Spare perforated shaft (corrugated)	0,4
214347	Spare eccentric shaft (smooth)	0,4



made
in
Germany

Binding rope

Made from hemp, eye splice at one end.

Order no.	Length m	Ø mm	Weight g
212660	2	8	75



Polyamide rope

All-purpose rope for securing, rescuing etc. Diameter 9 mm, breaking strain 1 t, length 100 m, on reel.

Order no.	Weight g
212720	4600

Tension belt

Ratchetlashing strap for securing loads. Width 50 mm, length 5000 mm, maximum load 2500 kg.

Order no.	Dimensions mm	max. tensile force kg	Weight g
212586	50 x 5000	2500	2250

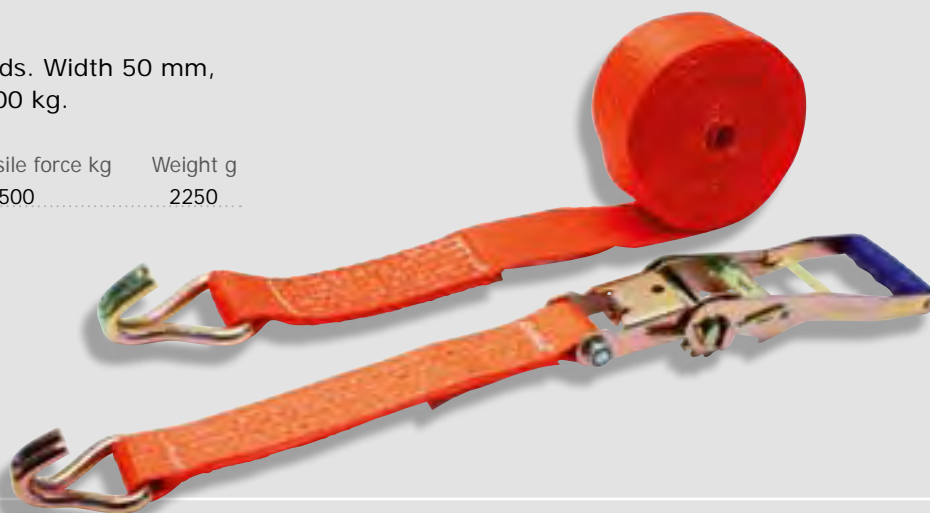

Vehicle bracket for petrol canister

For armed forces canisters. Sturdy version with retaining bracket, facility for attaching a padlock and mounting holes for screwing to the body. Painted black.

	Order no.	for canister size l	Weight g
1	280053	10	2500
2	280054	20	3000

Metal petrol canister

Stackable, UN-certified, for transporting hazardous materials in acc. with GGVS.

- Three standard colours: olive, yellow, red
- Other colours available on request
- Stove-enamelled
- TÜV and GS symbols

Order no.	Capacity l	Colour	Dimensions W x H x D mm	Weight g
280069	5	olive	310 x 230 x 120	1500
280070	10	olive	345 x 275 x 165	2900
280071	20	olive	345 x 466 x 165	4200
280072	10	red	345 x 275 x 165	2900
280073	20	red	345 x 466 x 165	4200
280074	10	yellow	345 x 275 x 165	2900
280075	20	yellow	345 x 466 x 165	4200



Spout, rigid

For armed forces canister, olive, with air hole.

Order no.	Length mm	Weight g
280076	190	240



With adapter for catalytic converter vehicles.

Spout, flexible

For armed forces canister, olive, with air hole.

Order no.	Length mm	Weight g
280077	260	260



Plastic petrol canister

With GGVS-certification. Including spout for catalytic converter vehicles

Order no.	Colour	Capacity l	Weight g
280078	black	5	500
280079	black	10	800

Double canister

Dual-chamber canister 5.5 + 3 l.

For fuel and fuel mixtures for operating small motors/ engines in power saws, lawn mowers etc.

- Oil container for lubricant (e.g. chain oil)
- Cams on side for holding tool keys
- Incl. spout
- UN certification in acc. with GGVS
- HD-PE material

Order no.	Item	Colour	Weight g
280080	Double canister	red	1100
210913	Safety discharge valve	black	200





Canvas bucket 10 l

Canvas fire extinguishing bucket, capacity 10 litres. With carrying handle and spout.

Order no.	Dimensions mm	Weight g
210914	340 x 335	120

Multipurpose bucket, flattened

German design with hoop-type steel base, with one side flattened.

Order no.	Diameter x Height mm	Capacity l	Weight g
210915	280 x 290	11	2100



Stainless steel bucket, flattened

Made from stainless steel 18/8, 10 l, one side flattened.

Order no.	Diameter x Height mm	Capacity l	Weight g
218580	285 x 260	10	2400

Stainless steel funnel

Made from 18/8 stainless steel.

Order no.	Ø mm	Weight g
218575	250	1100



Basin DIN 14060

With two folding handles, stackable.

Made from hot-galvanised steel plate, DIN 14060

Order no.	Dimensions mm	Weight g
210910	600 x 400 x 120	4000

Made from stainless steel, similar to DIN 14060

Order no.	Dimensions mm	Weight g
210911	600 x 400 x 180	6500

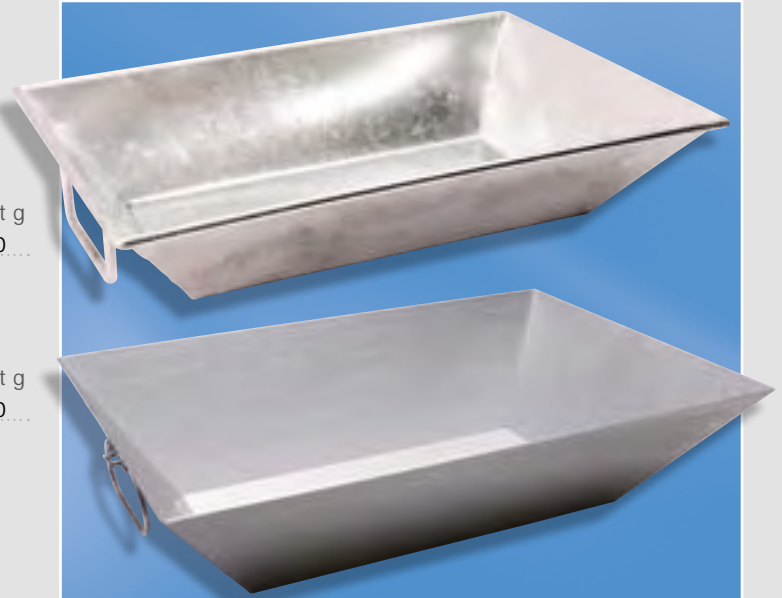
**Waste bin**

Simple and robust waste container for any use. Quickly set up, this waste container holds normal commercial waste sacks with a capacity of 70 to 120 litres. Full (and therefore heavy) waste sacks also securely held. The galvanised frame is permanently protected from rusting. Waste container can be stowed away without taking up much room when dismantled.

Order no.	Ø x Height mm	Weight g
280036	370 x 970	4200

**Flat sack**

Made from transparent polythene, with sack seal.

Order no.	Dimensions mm	Weight g
214166	1500 X 80	390

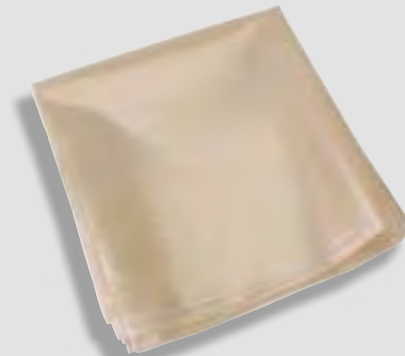
**Waste sack 120 litres**

Thickness 80 µ, colour blue.

Order no.	Dimensions mm	Weight g
280139	700 x 1100	75





Car towing rope

Made from polyamide, with red warning flag and two load hooks, towing capacity 2.5 t, 18 mm Ø.

Order no.	Length m	Weight g
212710	4	1000

Towing rope DIN 76031

Made from steel, with red warning flag and two eyes with cable eye stiffeners, breaking strain 15 t, 16 mm Ø.

Order no.	Length m	Weight g
212715	5	5000

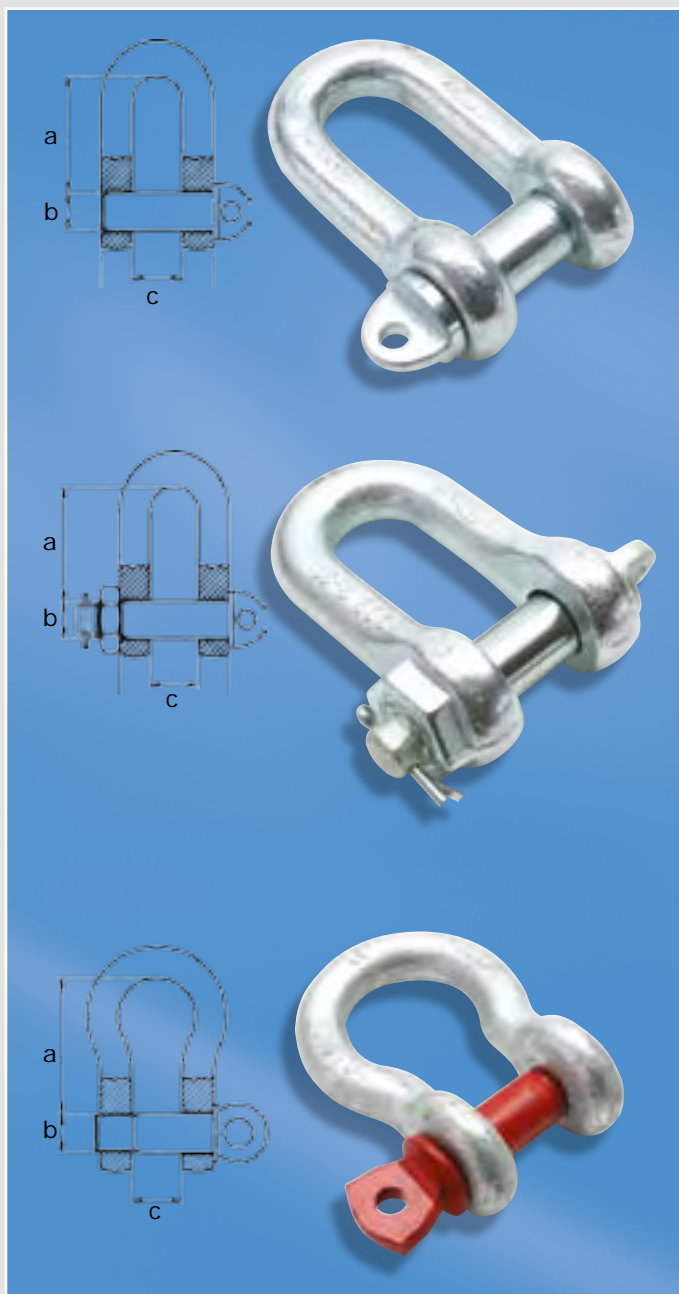

Shackle DIN 82101-A

With eye screws, made from electrogalvanised steel.

Order no.	Nominal size	measure acc. painting a x b x c/mm	Load capacity t	Weight g
212940	1	49,0 x 16 x 21	1	400
212945	3	83,5 x 27 x 38	3	2100
212955	5	111,0 x 36 x 47	5	3900

Shackle DIN 82101-C heavy duty

The classical fire brigade shackle. The quality class 8 steel gives the shackle an extremely high load-bearing capacity in a compact design. Shackle and nut are from a single forging die. Bracket hot galvanised, screw electrogalvanised.

Order no.	Nominal size	measure acc. painting a x b x c/mm	Load capacity t	Weight g
212960	1,6	61,0 x 20 x 27	5	800
212965	3	83,5 x 27 x 38	10	2000
212970	5	111,0 x 36 x 47	15	4400

Shackle curved, heavy duty

With eye screw, made from electrogalvanised, high-strength steel and painted screw. Complies with requirements of DIN 14555-T3 (equipment vehicle loading).

Order no.	Nominal size	measure acc. painting a x b x c/mm	Load capacity t	Weight g
212980	1-1/8"	103,0 x 33 x 46	9,5	3200
212975	1-1/4"	119,0 x 36 x 52	12	4300

Nails DIN 1151

Shape B, countersunk head, corrugated, hot-galvanised. Supplied in packets.



Order no.	Size mm	Weight g/packet
218200	3.0 x 65	2500
218205	3.0 x 80	2500
218210	3.8 x 100	5000
218215	4.6 x 120	5000
218220	5.5 x 140	5000

Rib nails

Steel, galvanised. Supplied in packs of 100.

Order no.	Dimensions mm	Weight g/packet
218340	4 X 60	600



Dry wall screws

With countersunk head, PZ cross recess, galvanised. Supplied in packets.



Order no.	Size mm	pu/pc.	Weight g/packet
218295	4 X 45	200	500
218300	5 X 60	200	1060
218305	6 X 80	100	1000

Hexagon wood screws DIN 571

Electro-galvanised. Supplied in packs of 25.

Order no.	Size mm	Weight g/packet
218285	6 x 100	430
218290	8 x 120	920



Washer DIN 9021

Version A, scoured U-washers, galvanised. Supplied in packs of 25.

Order no.	For screw	Internal Ø mm	External Ø mm	Weight g/packet
218240	M 6	6,4	18	60
218245	M 8	8,4	24	125
218250	M 10	10,5	30	320
218255	M 12	13	37	450
218260	M 16	17	50	930
218265	M 20	20	56	1700

All-purpose expansion plug

Made from polyamide, for use in any surface. Supplied in packets.

Order no.	Dimensions mm	pu/pc.	Weight g/packet
218310	6 X 30	100	60
218315	8 X 40	100	140
218320	10 X 50	50	130
218325	12 X 60	40	100



Threaded bars DIN 976

DIN 976-1-8.8, made from steel, galvanised.

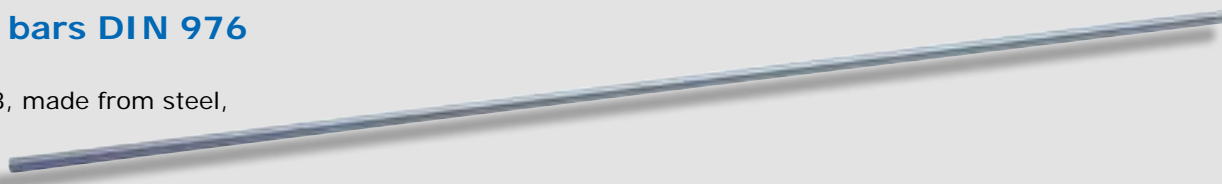

Order no.	Size	Weight g
218225	M 12 x 1000 mm	455
218230	M 16 x 1000 mm	1300
218235	M 20 x 1000 mm	2020



Hexagon nuts DIN 934-8

ISO 4032, electrogalvanised.
Supplied in packs of 25.

Order no.	Size	Weight g/packet
218270	M 12	390
218275	M 16	750
218280	M 20	1400

Joist hanger

Tabs on the outside, model 100 x 140 mm.

Order no.	Weight g
218345	440

Perforated plates and brackets

(Nail connectors) for nail connections in acc. with DIN 1052-2, galvanised.

Bracket

Order no.	Dimensions mm	Weight g
218350	90 x 90 x 2.5	200
218355	100 x 100 x 3	380

Plate

Order no.	Dimensions mm	Weight g
218360	100 x 200 x 2	280

Press-fit dowel DIN 1052

Annealed cast iron wood connector, two-sided, galvanised. Supplied in packs of 10.

Order no.	External Ø mm	Internal Ø mm	Weight g/packet
218330	80	48	160
218335	95	65	190

Cramp iron DIN 7961

Design A (pulling clamp).
Design C (composite clamp), with two drill holes.

Order no.	Model	Size mm	Weight g
1 213010	A	300 x 90 x 16	700
2 213015	C	300 x 70 x 30	600



Iron wire 2 mm Ø

Galvanised, on reel, length 50 m.

Order no.	Weight g
218365	1300

Cable ties

In acc. with DIN EN 50146 (VDE 0604 Part 201), made from polyamide, natural colour. Supplied in packs of 100. Other dimensions on request

Order no.	Length x Width mm	Weight g/packet
217640	360 x 4.5	240





Supplied
without adhesive tape.

Portable adhesive tape dispenser

Sturdy, lightweight portable dispenser for adhesive tape up to 50 mm wide and with core diameter of 75 mm. Easy to insert, dispense and cut off even extremely sturdy adhesive tape. Made in Sweden.

Order no.	Length mm	Weight g
217536	240	400

Fabric adhesive tape 50 mm x 50 m

Extremely sturdy adhesive tape with fabric inlay, silver-grey, extremely adhesive. Core diameter 75 mm.

Order no.	Weight g
217535	250

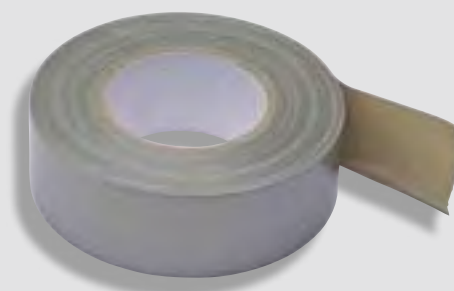



It is vital to have a reliable power supply and good lighting at the operation site. Even under adverse conditions, power generators, cable reels and floodlights must 100% operational and robust.

Dönges provides you with the quality and innovations that you expect – at affordable prices.



Batteries/Rechargeable batteries

Alkaline batteries	192	NiMh batteries	193
Lithium batteries	192	Charger	193



Lighting/Tripods

Halogen floodlight	194-195	Cordless workplace floodlight	199-200
HID floodlight	196		
Tripods for standard pins	197-198		



Cable reels

Fire brigade reels	201-202	THW reels	203-205
--------------------	---------	-----------	---------



Distributors

Three-way distributor	206-207	Block-type distributors	208-210
Receptacles strips	207		



Cables/ plug-in connectors

Personnel protection switches	211	Rubber cables	215-216
Extension cables	212-214	Receptacles/plugs 230 V	217-218
Special cables	214-215	Receptacles/plugs 400 V	219



Generators

Honda	220	Earthing accessories	225
Endress	221-224	Exhaust hose	225

Duracell alkaline batteries

You must be able to rely on batteries during operations. Regardless of whether they are supplying power in a helmet lamp, a torch, a pulse oximeter, or even in the AED: people's lives can depend on the performance capability of the batteries.

We therefore strongly recommend the use of alkaline brand name batteries. You can only be certain of having tested and reliable quality if these products are used. We therefore have DURACELL alkaline brand name batteries in our product range.



DURACELL was the first manufacturer to develop the electro-chemical alkaline manganese dioxide system almost 40 years ago. Between 1960 and 1970 this battery system became the most frequently used battery type in electronic equipment. Alkaline or alkaline manganese dioxide batteries provide various advantages in comparison to carbon zinc batteries such as up to ten times as much Ampère-hour capacity with high, continuous discharging conditions. Their high performance capability at low temperatures makes them superior to conventional primary cells containing electrolyte. Other significant advantages are a longer service life, better sealing and superior performance at low temperatures. Their improved, reliable sealing ring provides excellent resistance to leaks and corrosion.

Order no.	Size	Voltage V	PU	Weight g
241002	AAA/Micro/LR03	1,5	24	15
241006	AA/Mignon/LR06	1,5	4	20
241010	C/Baby/LR14	1,5	1	67
241014	D/Mono/LR20	1,5	1	140
241018	9 V Block/6LR61	9,0	1	45
241022	4,5 V Block/3LR12	4,5	12	170

Energizer Ultimate lithium batteries

Lithium batteries are particularly suitable for applications that require high performance over long periods of time because of their high voltage and excellent capacity. Other advantages are the extremely long storage capability because of the low self-discharge rate, and the wide temperature range for storage and operation. Energizer Ultimate lithium batteries provide top performance for energy-intensive equipment and therefore provides it with the necessary power.

Order no.	Size	Voltage	PU	Weight g
241102	CR123	3.0 V	1	15
241106	AAA/Micro/L92	1.5 V	2	23
241108	AA/Mignon/L91	1.5 V	4	25



Energizer NiMH batteries

Rechargeable batteries are a financially and ecologically meaningful alternative to batteries. Nickel-metal hydride cells are less robust than nickel-cadmium cells, but they have a greater capacity and the best products can match the capacity of lithium systems. The lazy battery effect, comparable with the classical memory effect in NiCd batteries, is no problem when intelligent charging technology is used.

The combination of the Energizer and rechargeable batteries is the right product for all applications. Energizer rechargeable batteries provide maximum output, which can be reactivated several hundred times. However, please note that some manufacturers restrict or forbid the use of certain devices with rechargeable batteries (e.g. explosion-proof helmet lamps). The operating instructions of the relevant device must be carefully checked beforehand before using rechargeable batteries rather than conventional batteries.



Order no.	Size	Voltage/capacity	PU	Weight g
241052	AAA/Micro/LR03	1.5 V/ 850 mAh	2	15
241056	AA/Mignon/LR06	1.5 V/ 2500 mAh	2	20
241060	C/Baby/LR14	1.5 V/ 2500 mAh	2	60
241064	D/Mono/LR20	1.5 V/ 2500 mAh	2	130
241068	9 V Block/6LR61	9 V/ 175 mAh	1	50

Energizer universal charger

The Energizer universal charger detects the chemical composition, the capacity and even batteries that are unsuitable. The charger is compatible with all popular rechargeable battery sizes. Suitable for AAA, AA, C, D and 9 V batteries

Order no.	Battery types	Weight g
241120	AAA/AA/C/D/9 V Block-type batteries	127



Fire Brigade 500 W halogen floodlight

The Dönges 500 W floodlight is a top quality, cost-efficient halogen operational floodlight with special modifications for the fire brigade and rescue area. A bracket is attached for swivelling the switched-on floodlight. The DIN 14640 trunnion mount allows the equipment to be attached to any mounting bridge or tripod with appropriate trunnion mounts. The housing is water spray proof, and the floodlight is equipped with a 10 m long connecting cable and a waterproof grounding type receptacle. The scope of supply includes a Hook & Loop fastener for securing the connecting cable.

Features:

- Aluminium housing and handle
- Output 500 Watts
- 10 m connecting cable H07RN-F3G1.5 with waterproof (IP68) Schuko® plug
- Width x Height x Depth, with handles and clamp: 185 x 300 x 140 mm
- Floodlight protection class IP44
- Glass protected by grille

Order no.	Item	Dimensions mm (W x H x D)	Weight g
221303	Floodlight	185 x 300 x 140	3100
221314	Spare lens		500
221313	Spare bulb		10



Handles can also be used for swivelling when hot during operation

Fire brigade 1000 W halogen floodlight

Top quality, cost-effective 1000 W halogen floodlight with modifications for the fire brigade and rescue area. Two thermally decoupled handles are attached for swivelling the floodlight during operation. Two DIN 14640 trunnion mounts allow the equipment to be universally attached to any bridge or tripod. The scope of supply includes a Hook & Loop fastener for securing the connecting cable - the cable can also be wound around the handles.

Features:

- Aluminium housing and handles, clamp made from steel
- Output 1000 Watts
- 10 m connecting cable H07RN-F3G1.5 with waterproof (IP68) Schuko® plug
- Width x Height x Depth, with handles and clamp: 335 x 350 x 140 mm
- Protection class IP54

Order no.	Item	Dimensions mm (W x H x D)	Weight g
221302	Floodlight	335 x 350 x 140	4200
221299	Spare lens		600
270874	Spare bulb		15



Clamp for secure, universal mounting on tripods and bridges



10 m connecting cable and high-quality, waterproof Schuko® connector Mennekes.



The two handles are also suitable for winding up the connecting cable



1000 W halogen floodlight

High-end 1000 W halogen floodlight with modifications in accordance with THW specifications for use by fire brigades, rescue services and the disaster relief area. With clamp for standard pin in acc. with DIN 14640.

Optionally available with handle. This handle makes it easy to swivel and carry the floodlight, even when hot. The handle is thermally insulated, and can also be used wearing gloves. Another advantage is that the handle does not change the outer dimensions of the floodlight, since it does not protrude. The handle can also be used when reeling up the cable - the cable will not slip off.

Housing made from corrosion-resistant diecast aluminium with cooling fins. Reflector with diffuse scattering made from pure aluminium 99.98 %, chemically polished and anodised. With hinged, high temperature-resistant safety glass front lens mounted in silicone seal. For all bulbs QT-DE 1000 W R7s, 185.7 mm.

Features:

- Output 1000 Watts
- Connecting cable H07RN-F3G1.5 with waterproof (IP68) Schuko® plug
- Dimensions with clamp: 290 x 155 x 330 (W x D x H mm)
- Protection class IP54
- Wide-ranging light distribution
- Bulb with lighting current of 21,000 lm
- Joint with two star grips

Scope of delivery:

Floodlight (with bulb, ready for use), with bracket and trunnion mount, spare light source, spare front lens, re-usable Hook & Loop tape for rolling up the cable.

Order no.	Item	Connecting cable m	Weight g
221306	Halogen floodlight without handle	7	4300
221307	Halogen floodlight with handle	7	4300
270803	Halogen floodlight without handle	10	5000
270805	Halogen floodlight with handle	10	5000
270806	Spare lens		505
270874	Spare bulb		15



made
in
Germany

exclusive *DÖNGES*



With swivelling and carrying handle (optional)



The handle also makes it possible to safely roll up the cable

Fire brigade floodlight HID250

This floodlight represents the latest lighting technology for fire brigades and rescue services at a cost-efficient price.

The HID metal vapour discharge floodlight is a substitute for up to 1000 W of halogen luminance, and uses just 250 W.

The housing does not heat up to a considerable degree, even after long periods of use, and can be put back in the vehicle immediately after use.

The vibration stability of the floodlight is also several times better than that of a halogen searchlight.

The DIN 14640 trunnion mount allow the floodlight to be universally attached to any bridge or tripod.

Features:

- Housing made from extremely impact resistant ABS, handles made from steel and plastic, swivelling bracket made from stainless steel, clamp made from steel
- Output 250 Watts
- 10 m connecting cable H07RN-F3G1.5 with waterproof (IP68) Schuko® plug
- Width x Height x Depth, with handle and clamp: 530 x 640 x 180 mm
- Protection class IP66

Order no.	Item	Dimensions mm (W x H x D)	Weight kg
221308	Floodlight HID 250	530 x 640 x 180	11,0
221311	Spare bulb		0,3
221309	Safety grille		0,7



Extremely large metal clamping lever for adjusting the beam angle, can be operated using gloves without problems.

Large, convenient carrying handle, also easy to use wearing gloves.



exclusive **DOENGES**



Telescopic tripod 4,5 m

The new Dönges telescopic tripod reaches an extended height of 4.5 m, is extremely stable and stands absolutely rock solid at this height due to the supplied and easy-to-use anchoring set. A long service life is guaranteed by the top quality workmanship.

When it is not extended, the tripod is 1.12 m long and weighs 13.3 kg. It can therefore be stored on the different vehicles without problems, even using existing holders. The extending feet easily compensate for uneven floors.

All of the securing mechanisms have large wing screws and can be easily and reliably operated wearing gloves. The tubes are clamped using a large contact pressure mechanism, which prevents the individual telescopic tubes from distorting.

The steel tubes are electro galvanized or painted in warning colour yellow RAL 1012. In the collapsed condition, the tripod can be secured using a captive tension strap. A centring component holds the legs securely together.

The standard pin Ø 30 mm for retaining floodlights and bridges complies with DIN 14640.

Features:

- Extended height 4.58 m
- Collapsed length 1.12 m
- Maximum load 25 kg
- Complete with anchoring set consisting of three metal pegs and three tensioning ropes with quick tensioners and karabiners

Order no.	Item	Weight kg
221300	Telescopic tripod	13,3
1 221301	Spare anchoring set	1,1



DÖNGES
exclusive



Special fitting for centring the legs when collapsed. Captive tension strap.



We use a special adjustable clamping system so that the tubes are not deformed.



Anchoring set included in scope of delivery

Tripod stand DIN 14683

Lightweight tripod for one searchlight with clamp in acc. with DIN 14640. The tripod can be quickly and easily adapted to uneven terrain using the three extending legs. The profiled feet ensure that the tripod is securely anchored.

The steel tubes are electro galvanized or painted in warning colour yellow RAL 1012. In the collapsed condition, the tripod can be secured using a captive tension strap.

Features:

- Extended height 1.62 m
- Collapsed length 1.05 m
- Maximum load 10 kg

Order no.	Length collapsed/extended mm	Weight kg
221305	105/162	4,0

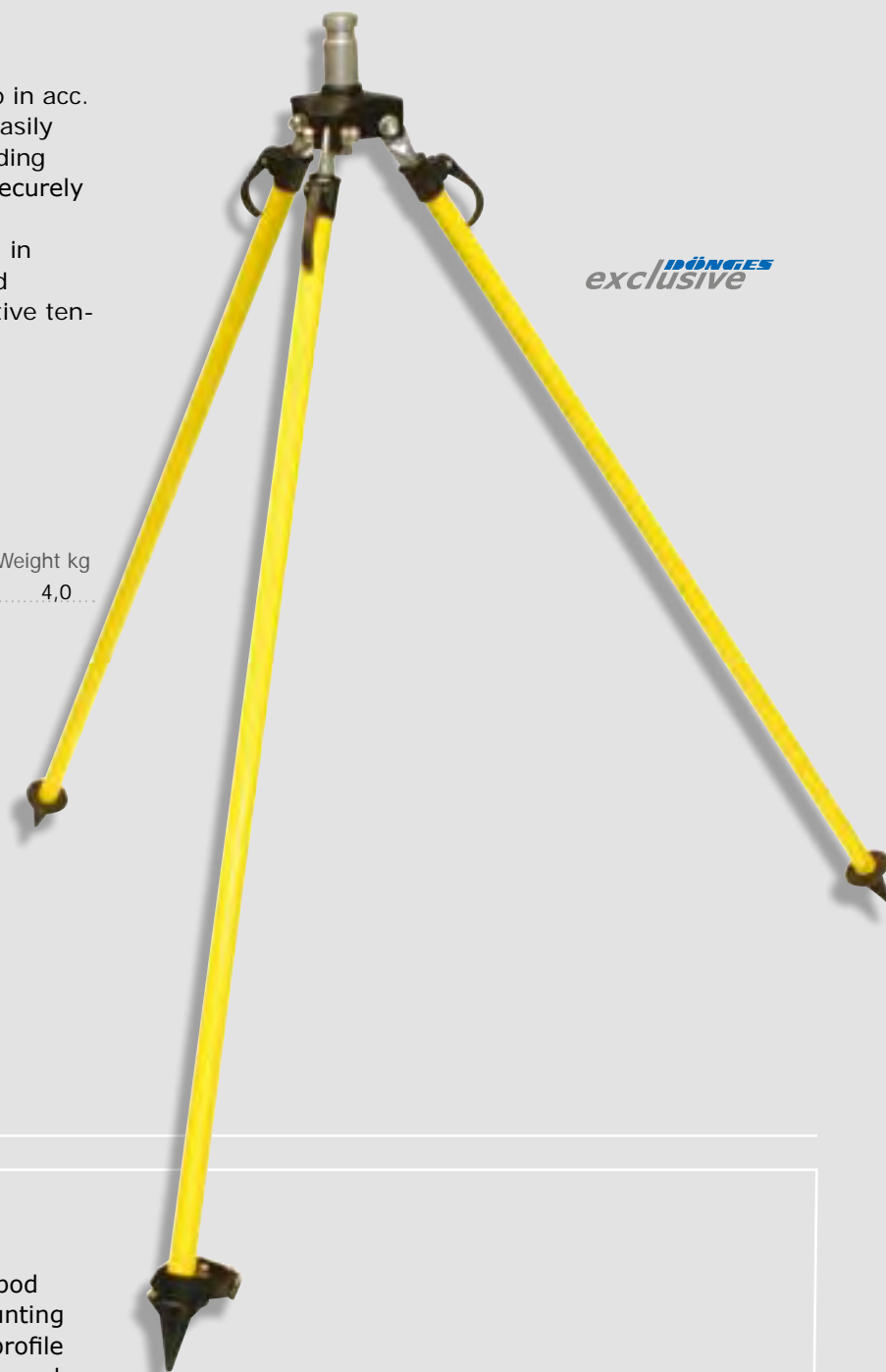

Floodlight mounting bridge

Two halogen floodlights can be mounted on a tripod stand with standard pin using this floodlight mounting bridge. The mounting bridge consists of a steel profile with two DIN-compliant aluminium receiving pins and an adapter made from steel for securing the bridge to the standard pin of the tripod.



Features:

- Suitable for all tripod stands and floodlights with Pins/collets as per DIN 14640

Order no.	Pin spacing mm	Weight kg
270876	350	1,8
221304	450	1,9
270878	505	2,0
270880	600	2,1

■ made in Germany



Cordless workplace floodlight MAXI 9000

The MAXI 9000 is a battery-operated workplace floodlight that is handy, mobile and provides maximum luminance. This extremely stable floodlight consists of a polythene housing with a polycarbonate front lens, which will also withstand hard impacts. It contains two fluorescent tubes with 42 W and 57 W. In economy mode only the 42 W lamp is used. This provides an adequate amount of light for the maximum operating time. If more brightness is required, the 57 W lamp can also be used. The luminance is also optimised by a mirror finished aluminium reflector.

The standard battery that is supplied is a 12 V lead gel battery with a capacity of 24 Ah. With the standard light configuration of 42 W and 57 W and the maximum brightness of 7500 Lumen, this provides an operating time of about 3 hours with a single battery charge. More powerful NiMH batteries are optionally available that almost double the operating time.

Features:

- Adequate lighting, independently of any power source
- Lightweight and compact
- Two different brightness levels
- Powerful battery
- Can be extended to a height of 2.20 m
- Extensive range of accessories available

Scope of delivery:

Lamp with 1 x 42 W and 1 x 57 W tubes, leadgel-battery 24 Ah, extending foot, mains charger

Order no.	Item	Weight g
221315	Maxi 9000 24 Ah (standard)	18000
221316	Maxi 9000 38 Ah	18000
221317	Spare tube 42 W	100
221318	Spare tube 57 W	120
221319	Spare battery 24 Ah (lead gel)	7800
221321	Spare battery 38 Ah (NiMH)	13200
221323	230 V charger	600
221324	Vehicle adapter cable	50



Battery-operated workplace floodlight Megastar

The Megastar is impressive because of its tremendous luminous efficiency. The four built-in 36 W fluorescent tubes provide 11,600 Lumen of luminance. At full power, the 24 Ah lead battery will provide two hours of light. The floodlight can also be switched to operation with one tube. This increases the operating time with one battery charge of the 24 Ah battery to four hours. The optionally available 38 Ah battery will provide three or six hours of light.

As standard the Megastar is supplied with a tripod, which can be extended to a height of up to 3.50 m.

Features:

- Adequate lighting, independently of any power source
- Lightweight and compact
- Two different brightness levels
- Powerful battery
- Tripod can be extended to a height of 3.50 m
- Extensive range of accessories available

Technical data:

Bulb:	4 x 36 Watts
Luminance:	11,600 lumen
Standard battery:	24Ah lead gel battery
Optionally available:	38Ah lead gel battery
Operating time with 24 Ah battery:	144 W=2 hrs./72 W=4 hrs.
Operating time with 38 Ah battery:	144 W=3 hrs./72 W=6 hrs.
Charging time for 24 Ah battery:	6 hrs.
Charging time for 38 Ah battery:	10 hrs.

Standard scope of delivery:

Lamp with 4 x 36 W tubes, 24 Ah lead gel battery, tripod, mains charger

Order no.	Item	Weight g
221332	Megastar 24 Ah (standard)	19400
221333	Megastar 38 Ah	24800
221334	Spare tube 36 W	100
221335	Spare battery 24 Ah (lead gel)	7800
221336	Spare battery 38 Ah (lead gel)	13200
221337	230 V charger	600
221338	12 V charger	50



Dönges cable reel all-rubber as per EN 61316

Uncompromising professional range made from hard rubber with double tubular frame for the fire brigade, THW and the disaster relief area. Protection class IP54 in acc. with EN 60529 for harsh outdoor conditions and also in adverse weather conditions (IP67 currently in preparation).

The reel unit made from vulcanized hard rubber ensures that the reel has top performance characteristics, is absolutely unbreakable, oil and grease resistant and provides maximum electrical safety. The extremely sturdy double tube frame, made from 22 mm or 25 mm galvanized steel tube, is simply indestructible.

Dönges only uses sulphur yellow extremely flexible special rubber cable compliant with DIN VDE 0282

Other features:

- Maintenance-free, weatherproof and ageing resistant
- Low design for perfect stability
- All versions with thermal overload protection in acc. with EN 60730-T1
- Fully insulated in acc. with protection class 1
- All top quality armed forces plug-in devices in accordance with the latest defence equipment standard from Mennekes



- All plug-in devices and cables are individually replaceable
- All wire ends are fitted with insulating shaft wire-end ferrules



Protection class IP54 (IP67 is in preparation) by means of rubber seal ring, which seals the connecting compartment perfectly. The smaller reels are securely screwed together with nine screws (large ones with 12). An IP68 cable screw fitting at the kink-free cable lead-in in the drum unit ensures that it is waterproof. Double strain relief in drum unit.



Easy to carry using ergonomic handles and perfectly balanced frame. The special design of the safety carrying handle prevents the reel from swinging away from the body and also prevents contact with the body when it is being carried - i.e. no arm twisting. The heavier THW reels have a special three-handle frame, which also allows the reel to be carried by two people.



Three large crank handles (one with rotating handle) also protect the receptacles from damage, even if the reel lands on its "head". The handles also protect protruding receptacles from being damaged. The versions with 5G6 cables have a hinged crank handle.

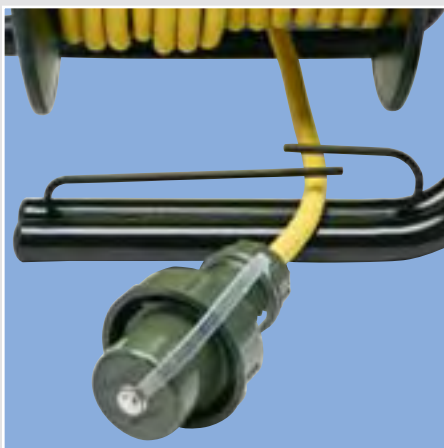

The unique cable guide prevents the cable from fouling when it is being reeled in and out. The cable can be simply inserted into and removed from the guide (karabiner hook system), where it is guided over the entire width of the reel and prevented from slipping off the edges.



The special design of the extremely sturdy frame prevents the cable from slipping behind the reel. The tubes that lead to the handle are routed so closely to the reel that the cable cannot slip behind them and become tangled.



Pressed-in steel tube axle with central brake. Steel on steel provides extremely smooth running. The reel is prevented from uncoiling (i.e. braked) via a large star grip and the maintenance-free, internal brake.

Dönges all-rubber cable reel "Fire Brigade"

Our EN 61316-compliant reels are small and compact, and therefore fit in any existing vehicle apertures. The extremely sturdy double tube frame (22 mm Ø) is silver coated.

Both reels are approved in accordance with all of the usual vehicle loading standards (LF/HLF 10/6, LF/HLF 20/16, equipment vehicle and TSF-W).

230 V, 16 A, 50 m cable 3G2.5 three grounding type receptacle

The latest version in the fire brigade area.

Configuration:

Input: 1 x waterproof (IP68) Schuko® plug 16 A, bronze green, compliant with VG 96926

Output: 3 x waterproof (IP68) Schuko® grounding type receptacles 16 A, bronze green, compliant with VG 96926

Order no.	Dimensions W x H x D mm	Weight kg
221312	315 x 370 x 290	16

made
in
Germany



DÖNGES
exclusive



230/400 V, 16 A, 50 m cable 5G2.5 one CEE- and three grounding type receptacle

Configuration:

Input: 1 x waterproof (IP67) CEE plug 16 A, bronze green, compliant with VG 96926

Output: 3 x waterproof (IP68) Schuko® grounding type receptacles 16 A, bronze green, compliant with VG 96926

1 x waterproof (IP67) CEE receptacle 16 A, bronze green, compliant with VG 96926

Order no.	Dimensions W x H x D mm	Weight kg
221322	350 x 430 x 295	20,5

made
in
Germany



DÖNGES
exclusive

Dönges all rubber cable reel "THW" in acc. with EN 61316

The THW makes special demands of the cable reels — the frame therefore double galvanized and has a double black powder coating. The cable reels are small and compact, and therefore fit in any existing THW vehicle apertures.

The heavier models weighing 20 kg or more are equipped with three insulated ergonomic handles, which allow the reels to be conveniently carried by two persons.

The models with two grounding type receptacle are available in two versions L1/L2 and L3/L2, in order to avoid generator out-of-balance. The covers are clearly marked.



230 V, 16 A, cable 3G2.5 three grounding type receptacle

Configuration:

Input: 1 x waterproof (IP68) Schuko® plug 16 A, bronze green, compliant with VG 96926
 Output: 3 x waterproof (IP68) Schuko® grounding type receptacles 16 A, bronze green, compliant with VG 96926

230/400 V, 16 A, 25 m cable 5G2.5 three grounding type receptacle

Configuration:

Input: 1 x waterproof (IP67) CEE plug 16 A, bronze green, compliant with VG 96926
 Output: 3 x waterproof (IP68) Schuko® grounding type receptacles 16 A, bronze green, compliant with VG 96926

Order no.	Dimensions W x H x D mm	Length m	THW no.	Weight kg
270814	315 x 370 x 290	25	6150T23433	9,2
1 270818	315 x 370 x 290	50	6150T22337	16,0

Order no.	Dimensions W x H x D mm	Length m	THW no.	Weight kg
2 270820	315 x 370 x 290	25	6150T31327	11,8



made in Germany

DÖNGES exclusive

MENNEKES®

230/400 V, 16 A, 25 m cable 5G2.5 one CEE and two grounding type receptacle

The reel is available in two variants L1/L2 and L3/L2. The two isolated ground receptacle are differently wired and clearly marked so that generator out-of-balance can be avoided, even if the supply network has a complex design.

Configuration:

- Input: 1 x waterproof (IP67) CEE plug 16 A, bronze green, compliant with VG 96926
- Output: 2 x waterproof (IP68) Schuko® grounding type receptacles 16 A, bronze green, compliant with VG 96926
- 1 x waterproof (IP67) CEE receptacle 16 A, bronze green, compliant with VG 96926

Order no.	Dimensions W x H x D mm	Model	Length m	THW no.	Weight kg
1 270817	315 x 370 x 290	L1/L2	25	6150T31328	12,1
2 270816	315 x 370 x 290	L3/L2	25	6150T31328	12,1



made in Germany

exclusive **DOENGES**

1



2

230/400 V, 16 A, 50 m cable 5G2.5 one CEE- and two grounding type receptacle

The three insulated ergonomic handles allow the reel to conveniently be carried by two people. The reel is available in two variants L1/L2 and L3/L2. The two isolated ground receptacle are differently wired and clearly marked so that generator out-of-balance can be avoided, even if the supply network has a complex design.

Configuration:

- Input: 1 x waterproof (IP67) CEE plug 16 A, bronze green, compliant with VG 96926
- Output: 2 x waterproof (IP68) Schuko® grounding type receptacles 16 A, bronze green, compliant with VG 96926
- 1 x waterproof (IP67) CEE receptacle 16 A, bronze green, compliant with VG 96926

Order no.	Dimensions W x H x D mm	Model	Length m	THW no.	Weight kg
1 270822	350 x 430 x 295	L1/L2	50	6150T22137	20,5
2 270819	350 x 430 x 295	L3/L2	50	6150T22137	20,5

made in Germany

exclusive **DOENGES**

MENNEKES®

400 V, 32 A, 25 m cable 5G6 one CEE- and two grounding type receptacle

The three insulated ergonomic handles allow the reel to conveniently carried by two people. The extremely stable double-tube frame is made from steel tubes with a diameter of 25 mm. The large crank handle is hinged. The receptacle fuses are behind a waterproof safety window.

The reel is available in two variants L1/L2 and L3/L2. The two grounding type receptacle are differently wired and clearly marked so that generator out-of-balance can be avoided, even if the supply network has a complex design.

Configuration:

- Input: 1 x waterproof (IP67) CEE plug 32 A, bronze green, compliant with VG 96926
- Output: 2 x waterproof (IP68) Schuko® grounding type receptacles 16 A, bronze green, compliant with VG 96926, each fused via a single-pole LS switch 16 A, C in each case
- 1 x waterproof (IP67) CEE receptacle 32 A, bronze green, compliant with VG 96926

Order no.	Dimensions W x H x D mm	Model Length m	THW no.	Weight kg
1 270824	350 x 440 x 380	L1/L2 25	6150T31127	25,0
2 270823	350 x 440 x 380	L3/L2 25	6150T31127	25,0



made in Germany

exclusive DÖNGES

Light/Energy

1

2

made in Germany

exclusive DÖNGES

MENNEKES®

400 V, 32 A, 30 m cable 5G6 one CEE- and two grounding type receptacle

The three insulated ergonomic handles allow the reel to conveniently carried by two people. The extremely stable double-tube frame is made from steel tubes with a diameter of 25 mm. The large crank handle is hinged. The receptacle fuses are behind a waterproof safety window.

The reel is available in two variants L1/L2 and L3/L2. The two grounding type receptacle are differently wired and clearly marked so that generator out-of-balance can be avoided, even if the supply network has a complex design.

Configuration:

- Input: 1 x waterproof (IP67) CEE plug 32 A, bronze green, compliant with VG 96926
- Output: 2 x waterproof (IP68) Schuko® grounding type receptacles 16 A, bronze green, compliant with VG 96926, each fused via a single-pole LS switch 16 A, C in each case
- 1 x waterproof (IP67) CEE receptacle 16 A, bronze green, compliant with VG 96926, fused via a three-pole LS switch 16 A, C

Order no.	Dimensions W x H x D mm	Model Length m	THW no.	Weight kg
1 270826	350 x 440 x 380	L1/L2 30	6150T23233	28,0
2 270825	350 x 440 x 380	L3/L2 30	6150T23233	28,0

Three-way distributor/delta boxes

The quickest, lightest and most compact way of distributing power. The housing consists of extremely sturdy chemical-resistant polycarbonate.

It is non-sensitive to the harsh conditions during fire brigade and disaster relief operations.

All of the plugs and receptacles are manufactured by Mennekes.



Three-way distributor "Delta box" 230 V, 16 A

The standard fire brigade distributor. Classical design with suspension bracket. Black rubber cable H07RN-F3G2.5 compliant with DIN VDE 0282. The distributor is completely waterproof (IP68).

Configuration:

Input: 1 x waterproof (IP68) Schuko® plug, 16 A

Output: 3 x waterproof (IP68) Schuko® grounding type receptacles 16 A

Order no.	Length m	Mennekes order no.	Weight g
221205	1,5	92386	1430



made
in
Germany

Three-way distributor "Delta box" 230/400 V, 16 A

Classical design with suspension bracket. Black rubber cable H07RN-F5G2.5 compliant with DIN VDE 0282. The distributor is completely waterproof (IP68) Schuko®.

Configuration:

Input: 1 x waterproof (IP67) CEE plug 16 A

Output: 2 x waterproof (IP68) Schuko® grounding type receptacles 16 A, hinge-connected

1 x waterproof (IP67) CEE receptacle 16 A, hinge-connected

Order no.	Length m	Mennekes order no.	Weight g
221210	2,0	92908	1720



made
in
Germany

Three-way distributor "Delta box" 400 V, 16 A

Classical design with suspension bracket. Black rubber cable H07RN-F5G2.5 compliant with DIN VDE 0282. The distributor is completely waterproof (IP68).

Configuration:

Input: 1 x waterproof (IP67) CEE plug 16 A,

Output: 3 x waterproof (IP67) CEE receptacles 16 A, hinge-connected

Order no.	Length m	Mennekes order no.	Weight g
221215	2,0	92909	1960



made
in
Germany

Three-way distributor "THW-Version" 230 V, 16 A

Extremely compact cube with suspension bracket. Sulphur yellow, extremely flexible special rubber cable H07RN-F3G2.5 compliant with DIN VDE 0282 (see page 216 for detailed description), available in three lengths. The distributor is completely waterproof (IP68).

Configuration:

Input: 1 x waterproof (IP68) Schuko® plug 16 A, bronze green, compliant with VG 96926
Output: 3 x waterproof (IP68) Schuko® grounding type receptacles 16 A, bronze green, compliant with VG 96926

Order no.	Length m	THW no.	Weight g
270890	1,5	6150T22437	1120
270892	2,5	6150T11712	1280
270894	10,0	6150T25219	2870



made
in
Germany

exklusiv **DÖNNGES**

All-rubber receptacle strip, four receptacles 230 V, 16 A

All-rubber distributor for continuous use outdoors. Can also be used under the harshest of conditions without problems and reliably. Suspendable and portable black IP54 housing. All of the plugs and receptacles are manufactured by Mennekes.

Equipped with 10 m sulphur yellow extremely flexible special rubber cable H07RN-F3G2.5 compliant with DIN VDE 0282 (see page 216 for detailed description).
Dimensions: 370 x 135 x 95 mm (L x W x H)

Configuration:

Input: 1 x waterproof (IP68) Schuko® plug 16 A, bronze green, compliant with VG 96926
Output: 4 x waterproof (IP68) Schuko® grounding type receptacles 16 A, bronze green, compliant with VG 96926

Order no.	Length m	Weight g
270872	10,0	5300



made
in
Germany

exklusiv **DÖNNGES**

MENNEKES®

All-rubber receptacle distributors

Almost indestructible all-rubber distributors for continuous use outdoors. Can also be used under the harshest of conditions without problems and reliably. Stackable and portable housing IP54. The connecting cable can be wound around the handle for carrying. The hinged-on cover is fitted with a stainless steel quick-release lock. All of the plugs and receptacles are manufactured by Mennekes.



Fuse protection beneath hinged-on cover



Cable winding on handle



Four-way "THW version", 230 V, 16 A

Equipped with 10 m sulphur yellow extremely flexible special rubber cable H07RN-F3G2.5 compliant with DIN VDE 0282 (see page 216 for detailed description). Black all-rubber housing. 306 x 230 x 287 mm (L x W x H).

Configuration:

Input: 1 x waterproof (IP68) Schuko® plug 16 A, bronze green, compliant with VG 96926

Output: 4 x waterproof (IP68) Schuko® grounding type receptacles 16 A, bronze green, compliant with VG 96926



made in Germany

Order no.	Length m	THW no.	Weight kg
270862	10	6110T25219	7,8

exclusive **HÖNGES**



made in Germany

Four-way "Fire brigade version" 230/400 V, 16 A

Equipped with 3 m black rubber cable H07RN-F5G2.5 compliant with DIN VDE 0282. Yellow all-rubber housing 306 x 230 x 287 mm (L x W x H).

Configuration:

Input: 1 x waterproof (IP67) CEE plug 16 A
 Output: 3 x waterproof (IP68) Schuko® grounding type receptacles 16 A, 1 x waterproof (IP67) CEE receptacle 16 A, fuse protected via FI switch 40/0,03 A

Order no.	Length m	Mennekes no.	Weight kg
221220	3	7401729	7,2

Eight-way "THW version", 230/400 V, 16 A

With 3 phase control lights and externally mounted equipment receptacle.
Connecting cable must be ordered separately (e.g. order no. 270844 on page 212).
The fuse protection can be found beneath the hinged housing cover with stainless steel quick-release lock.
Black all-rubber housing 360 x 340 x 330 mm (L x W x H).

Configuration:

Input: 1 x waterproof (IP67) CEE externally mounted equipment plug 16 A, bronze green, compliant with VG 96926

Output: 6 x waterproof (IP68) Schuko® grounding type receptacles 16 A, bronze green, compliant with VG 96926, fuse protected in pairs via three FI switches 0.40/0.03 A, C
2 x waterproof (IP67) CEE receptacles 16 A, bronze green, compliant with VG 96926, fused via two FI switches 40/0.03 A

Order no.	THW no.	Weight kg
270866	6110T11701	11,0

 **MENNEKES®**

made
in
Germany

DÖNGES
exclusive

**Six-way "THW version", 230/400 V, 32 A**

Equipped with 3 m sulphur yellow, extremely flexible special rubber cable H07RN-F5G6 compliant with DIN VDE 0282 (see page 216 for detailed description).
The fuse protection can be found beneath the hinged housing cover with stainless steel quick-release lock.
Black all-rubber housing 360 x 340 x 330 mm (L x W x H).

Configuration:

Input: 1 x waterproof (IP67) CEE plug 32 A, bronze green, compliant with VG 96926

Output: 3 x waterproof (IP68) Schuko® grounding type receptacles 16 A, bronze green, compliant with VG 96926, fuse protected via three FI/LS switches 16 A, C
2 x waterproof (IP67) CEE receptacles 16 A, bronze green, compliant with VG 96926, fused via two LS switch 16 A and one FI switch 40/0.03 A
1 x waterproof (IP67) CEE receptacle 16 A, bronze green, compliant with VG 96926, fused via a LS switch 32 A and one FI switch 40/0.03 A

Order no.	Length m	THW no.	Weight kg
270868	3	6150T31827	14,5

made
in
Germany

DÖNGES
exclusive

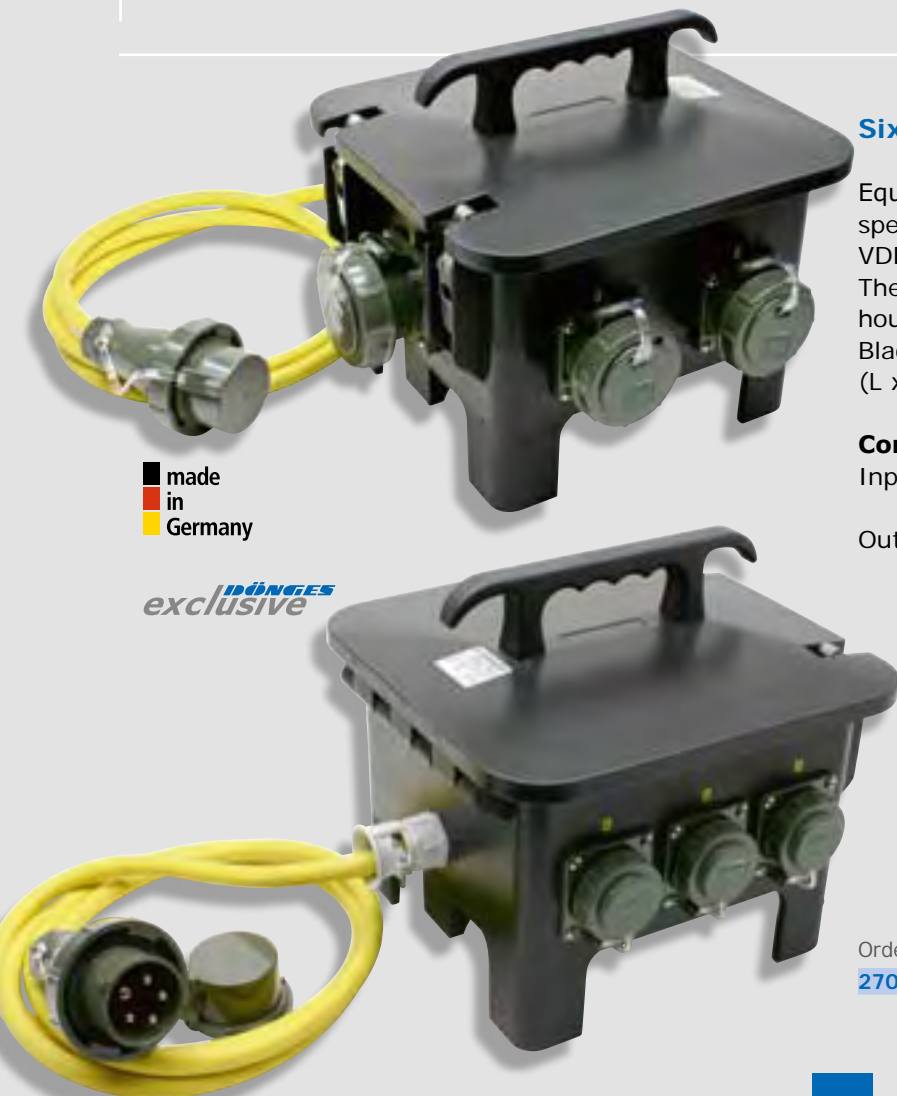

Six-way "THW version" 230/400 V, 63 A

Equipped with 3 m sulphur yellow, extremely flexible special rubber cable H07RN-F5G16 compliant with DIN VDE 0282 (see page 216 for detailed description). The fuse protection can be found beneath the hinged housing cover with stainless steel quick-release lock. Black all-rubber housing 360 x 340 x 330 mm (L x W x H).

Configuration:

Input: 1 x waterproof (IP67) CEE plug 63 A, bronze green, compliant with VG 96926
 Output: 3 x waterproof (IP68) Schuko® grounding type receptacle 16 A, bronze green, compliant with VG 96926, fuse protected via three FI/LS switches 16 A, C
 2 x waterproof (IP67) CEE receptacles 16 A, bronze green, compliant with VG 96926, fused via two LS switch 16 A and one FI switch 40/0.03 A
 1 x waterproof (IP67) CEE receptacle 32 A, bronze green, compliant with VG 96926, fused via a LS switch 32 A and one FI switch 40/0.03 A



Order no.	Length m	THW no.	Weight kg
270870	3	6150T23387	17,5



made
in
Germany

 **MENNEKES®**

DOENGES
exclusive

PRCD protection

Personnel protection switches are used to provide protection from any fault current that may occur during the operation of electrical equipment. The switch is connected between the power source (including generator) and the consumer like an power tool, and therefore provides reliable protection from electric shock.



Fire brigade version PRCD, 230 V, 16 A, 30 mA

For operation on power generator, 2-pole without protective conductor detection.
Equipped with black rubber cable H07RN-F3G1.5.

Order no.	Length m	Weight g
221297	2 (1.5 m upstream of switch and 0.5 m downstream of switch)	920
221298	5 (2.5 m upstream of switch and 2.5 m downstream of switch)	1130

Configuration:

- Input: 1 x waterproof (IP68) Schuko® plug 16 A, bronze green, compliant with VG 96926
- Output: 1 x waterproof (IP68) Schuko® grounding type receptacle 16 A, bronze green, compliant with VG 96926

■ made
■ in
■ Germany

exclusive **DÖNNGES**



THW version PRCD-S, 230 V, 16 A, 30 mA

The PRCD-S is a circuit-breaking portable residual current protection device with electronic fault current evaluation (PRCD = Portable Residual Current Device; S = safety) in the form of an intermediate cord device. It is particularly suitable as a safety distributor for all portable electrical equipment.

rubber cable H07RN-F3G2.5 in acc. with DIN VDE 0282 (see page 216 for detailed description).

Configuration:

- Input: 1 x waterproof (IP68) Schuko® plug 16 A, bronze green, compliant with VG 96926
- Output: 1 x waterproof (IP68) Schuko® grounding type receptacle 16 A, bronze green, compliant with VG 96926

Features:

- Residual current protection device
- Undervoltage tripping
- Protective conductor detection
- Protective conductor monitoring
- Interference voltage detection
- Protection in the event of interference voltage on the protective conductor

Order no.	Length m	THW no.	Weight g
270896	2	5925T23933	920

The PRCD-S detects the interference voltage on the protective conductor. However, the PRCD-S does not interrupt the protective conductor connection. The interference voltage can therefore isolate itself via its own upstream FI and LS protection devices.

Equipped with 2 m (1.5 m upstream of switch and 0.5 m downstream of switch) of sulphur yellow extremely flexible special



■ made
■ in
■ Germany

exclusive **DÖNNGES**

Extension cables "THW"

The THW makes extremely high demands of the extension cables that they use. We therefore always use an extremely high-quality cable for these extension cables.

This cable is characterised by having the following properties:

Features:

- Special, extremely flexible rubber cable
- Waterproof (IP68) Schuko® connectors and plugs
- Resistant to acids, alkalis, fuels and oil
- Extremely weather-resistant
- Excellent initial tearing resistance and continued tearing resistance
- Extremely abrasion-resistant sheath
- Extremely flexible
- Extremely high mechanical loading capacity
- Silicone-free
- Nominal voltage: 750 V

This special cable quality and the exclusive use of Mennekes connectors ensure that these cables can be safely used for many years, even under extremely adverse conditions.



made in Germany

exclusive DOENGES



230 V, 16 A, cable 3G2.5

Equipped with sulphur yellow extremely flexible special rubber cable H07RN-F3G2.5 compliant with DIN VDE 0282 (see page 216 for detailed description).

Configuration:

- Input: 1 x waterproof (IP68) Schuko® plug 16 A, bronze green, compliant with VG 96926
- Output: 1 x waterproof (IP68) Schuko® grounding type coupling receptacle 16 A, bronze green, compliant with VG 96926

Order no.	Length m	THW no.	Weight kg
270834	5	6150T22637	1,4
270836	10	6150T22537	2,4
270838	25	6150T11710	5,4

400 V, 16 A, cable 5G2.5

Equipped with sulphur yellow extremely flexible special rubber cable H07RN-F5G2.5 compliant with DIN VDE 0282 (see page 216 for detailed description).

Configuration:

- Input: 1 x waterproof (IP67) CEE plug 16 A, bronze green, compliant with VG 96926
- Output: 1 x waterproof (IP67) CEE coupling receptacle 16 A, bronze green, compliant with VG 96926

Order no.	Length m	THW no.	Weight kg
270844	5	6150T11704	2,0
270846	10	6150T11705	3,6
270848	15	6150T23533	5,2
270850	25	6150T22339	7,6

made in Germany

exclusive DOENGES



400 V, 32 A, cable 5G6

Equipped with sulphur yellow extremely flexible special rubber cable H07RN-F5G6 compliant with DIN VDE 0282 (see page 216 for detailed description).

Configuration:

- Input: 1 x waterproof (IP67) CEE plug 32 A, bronze green, compliant with VG 96926
- Output: 1 x waterproof (IP67) CEE coupling receptacle 32 A, bronze green, compliant with VG 96926

Order no.	Length m	THW no.	Weight kg
270854	10	6150T22438	5,7

made in Germany



DÖNGES
exclusive

Light/Energy

400 V, 63 A, cable 5G16

Equipped with sulphur yellow extremely flexible special rubber cable H07RN-F5G16 compliant with DIN VDE 0282 (see page 216 for detailed description).

Configuration:

- Input: 1 x waterproof (IP67) CEE plug 63 A, bronze green, compliant with VG 96926
- Output: 1 x waterproof (IP67) CEE coupling receptacle 63 A, bronze green, compliant with VG 96926

Order no.	Length m	THW no.	Weight kg
270840	5	6150T11702	8,3
270842	25	6150T23134	39,0

made in Germany



DÖNGES
exclusive

400 V, 125 A, cable 5G35

Equipped with sulphur yellow extremely flexible special rubber cable H07RN-F5G35 compliant with DIN VDE 0282 (see page 216 for detailed description).

Configuration:

- Input: 1 x waterproof (IP67) CEE plug 125 A, bronze green, compliant with VG 96926
- Output: 1 x waterproof (IP67) CEE coupling receptacle 125 A, bronze green, compliant with VG 96926

Order no.	Length m	THW no.	Weight kg
270852	25	6150T32122	74,0

made in Germany



DÖNGES
exclusive

MENNEKES®

10 m extension cable "Fire Brigade"

Black rubber cable H07RN-F3 G2.5 in acc. with DIN VDE 0282-4 (VDE 0282 Part 4).

Configuration:

Input: 1 x waterproof (IP68) Schuko® plug
DIN 49443, 16 A, protection class in acc. with
DIN EN 60529 (VDE 0470 Part 1)

Output: 1 x waterproof (IP68) Schuko® coupling recep-
tacle, 16 A, protection class in acc. with
DIN EN 60529 (VDE 0470 Part 1)

Order no.	Length m	Weight kg
221295	10	2,2



■ made
■ in
■ Germany

exclusive DOENGES

MENNEKES®



■ made
■ in
■ Germany

exclusive DOENGES

Vehicle connection adapter cable "THW"

230 V, 16 A, for feeding power into vehicles with three-
pole CEE externally mounted receptacle.

Equipped with sulphur yellow extremely flexible special
rubber cable H07RN-F3G2.5 compliant with DIN VDE
0282 (see page 216 for detailed description).

Configuration:

Input: 1 x waterproof (IP68) Schuko® plug 16 A,
bronze green, compliant with VG 96926

Output: 1 x waterproof (IP67) CEE coupling recep-
tacle, 3-pole 16 A, bronze green, compliant
with VG 96926,

Order no.	Length m	THW no.	Weight kg
270916	5	2540T11030	1,4

Adapter cable "THW" 400 V, 32 A

Connecting cable attached to IP54 black all-rubber
casing with handle.

Equipped with 5 m sulphur yellow, extremely flexible
Special rubber cable H07RN-F5G2.5 compliant with
DIN VDE 0282 (see page 216 for detailed description).
Dimensions: 370 x 135 x 95 mm (L x W x H)

Configuration:

Input: 1 x waterproof (IP67) CEE built-in equipment
plug, 32 A, bronze green, compliant with VG
96926, fuse protection via three-pole LS
switch 16 A, C

Output: 1 x waterproof (IP67) CEE coupling recep-
tacle 16 A, bronze green, compliant with
VG 96926

Order no.	Length m	THW no.	Weight kg
270914	5	5920T11702	5,3



■ made
■ in
■ Germany

exclusive DOENGES

Extension cables "THW"

This cable is intended to be a feed cable for domestic connections. The cable ends can be directly connected in the terminal box.

400 V, 63 A, cable 5G16

Equipped with sulphur yellow extremely flexible special rubber cable H07RN-F5G16 compliant with DIN VDE 0282 (see page 216 for detailed description).

Configuration:

- Input: 1 x waterproof (IP67) CEE plug 63 A, bronze green, compliant with VG 96926
- Output: End stripped, fitted with wire-end ferrules and labelled



exclusive DÜNGES

made in Germany

Order no.	Length m	THW no.	Weight kg
270828	3	6150T31388	5,4

400 V, 125 A, cable 5G35

Equipped with sulphur yellow extremely flexible special rubber cable H07RN-F5G35 compliant with DIN VDE 0282 (see page 216 for detailed description).

Configuration:

- Input: 1 x waterproof (IP67) CEE plug 125 A, bronze green, compliant with VG 96926
- Output: End stripped, fitted with wire-end ferrules and labelled



made in Germany

exclusive DÜNGES

Order no.	Length m	THW no.	Weight kg
270830	3	6150T31389	10,1

Feed cables "THW"

Heavy single-core cables made from black rubber cable H07RN-F1G95 in acc. with DIN VDE 0282.

Order no.	Length m	THW no.	Weight kg
270910	25	6150T32232	30,5
270912	50	6150T32231	61,0

made in Germany

exclusive DÜNGES



Special rubber cable H07RN, highly flexible, sulphur yellow

Special cable for absolute top quality. The outer material is cross-linked. The closed surface essentially prevents penetration from oil and chemicals. They are UV, ozone, weather and heat resistant and therefore extremely suitable for the different usage areas. All cables have tin-plated copper wires in copper class 5.

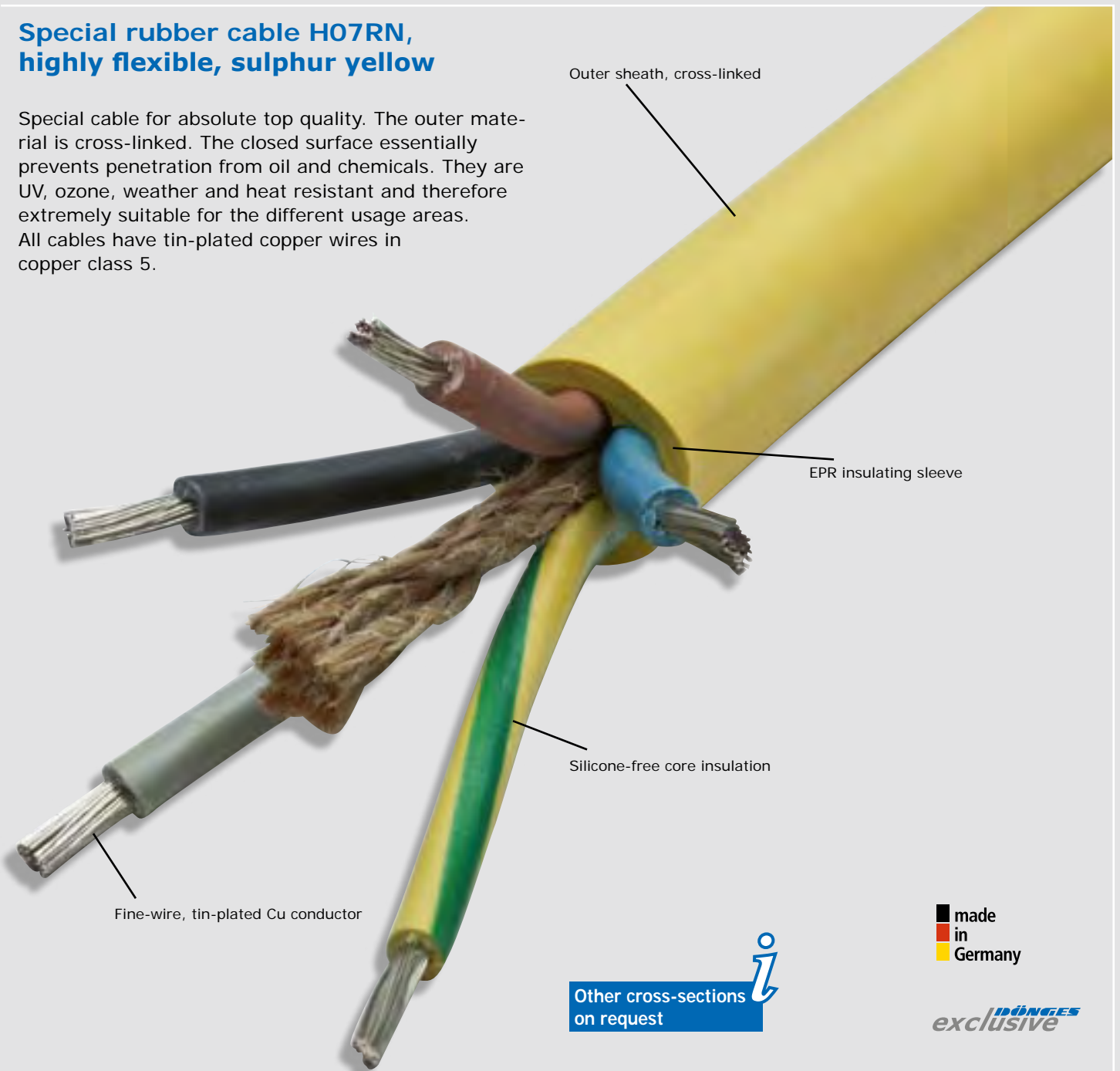

This configuration and the maximum flexibility make these cables suitable for continuous use outdoors.

Features:

- Outer sheath cross-linked and compressed
- Outer sheath with continuous surface
- UV, ozone, hydrolysis and weather resistant, flame resistant, immediately self-extinguishing and non-melting outer sheath mixture
- Tremendous initial tearing resistance
- Extremely flexible, also at low temperatures
- Tin-plated copper wires/internal cores
- No interaction between copper and wire insulating material
- Corrosion-free at connecting points
- Extremely long service life saves money

Technical data:

Nominal voltage: 450 V/740 V
 Test voltage: 2,000 V
 Cross-sections: up to max. 5 x 16 mm² possible
 Temperature: up to +60°C at conductor
 up to -25°C (moving)
 up to -40°C (stationary)
 self-extinguishing: DIN VDE 0482 T265-2-1
 Tensile load: max. 15 N/mm²
 Wire cross-section

Order no.	Cross-section	External Ø mm	Weight g/m
270900	3G2,5	11,5	235
270902	5G2,5	13,9	340
270904	5G6	18,9	630
270906	5G16	28,9	1540
270908	5G35	32,5	2700

The 5G35 cable is referred to as S07 according to the standard.



Waterproof Schuko® receptacles, Mennekes

Compliant with DIN 49442/43 and DIN VDE 0620. Housing and receptacle insert made from amaplast®. Protection class waterproof (IP68).

- Colour blue/grey
- 230 Volts / 16 Amperes
- Hammer-blow tested
- Bronze-green versions
compliant with defence equipment standard VG 96926



made in Germany

Schuko® panel mounted receptacle

With hinged bayonet cover, M 20 lead-in at top with screen fitting and M 20 dummy (for cutting out) at bottom.

Order no.	Mennekes order no.	Weight g
221260	10863	180



made in Germany

Schuko® panel mounted receptacle

With bayonet cover on hinge, with oval flange and two mounting holes.

Order no.	Mennekes order no.	Colour	Weight g
221225	10805	blue	96
221226	10803	bronze green	96



made in Germany

Schuko® panel mounted receptacle

With bayonet cover on hinge, square flange and four mounting holes. Alternatively with two breakthroughs.

Order no.	Mennekes order no.	Colour	Weight g
221235	10810	blue	107
221236	10812	bronze green	107



Schuko® panel mounted receptacle

With hinged-on bayonet cover, square flange and four mounting holes. Alternatively with two breakthroughs.

Order no.	Mennekes order no.	Weight g
221230	10808	109



made in Germany

Waterproof Schuko® plug, connector and receptacles Mennekes



Compliant with DIN 49442/43 and DIN VDE 0620.
Housing and receptacle insert made from amaplast®.
Protection class waterproof (IP68) (except for model 10818)

- 230 Volts / 16 Amperes
- Hammer-blow tested (except for model 10818)
- Bronze-green versions compliant with defence equipment standard VG 96919

Schuko® plug

With bayonet ring, with safety cover on strap, for cables up to 3 x 2.5 mm², up to H07RN-F.

- Colour blue/grey

Order no.	Mennekes order no.	Colour	Weight g
221245	10828	blue	134
221246	10829	bronze green	134



made
in
Germany

Schuko® angled plug

With cable screw fitting, for cables up to 3 x 2.5 mm², up to H07RN-F. Protection class IP66

Order no.	Mennekes order no.	Colour	Weight g
221240	10818	blue	125



made
in
Germany

Schuko® coupling receptacle

With bayonet cover on strap, for cables up to 3 x 2.5 mm², up to H07RN-F.

Order no.	Mennekes order no.	Colour	Weight g
221250	10833	blue	136
221251	10834	bronze green	136



made
in
Germany

Schuko® panel mounted receptacle

With bayonet ring, with safety cover on strap, M 20 lead-in at top with screw fitting and M 20 dummy (for cutting out) at bottom.

- Colour grey

Order no.	Mennekes order no.	Colour	Weight g
221265	10864	grey	200



made
in
Germany

Schuko® panel mounted receptacle

With bayonet ring, with safety cover on strap.

Order no.	Mennekes order no.	Colour	Weight g
221255	10852	grey	130
221256	10853	bronze green	107



made
in
Germany

Waterproof CEE plug-in devices, Mennekes



Compliant with DIN VDE 0623 and EN 60309-2.
Housing and receptacle insert made from amaplast®.
Protection class waterproof (IP67)

- Colour grey and/or identification colour
- 400 Volts / 16 Amperes
- 5-pin
- Bronze-green versions compliant with defence equipment standard VG 96919

panel mounted receptacle, straight

With screw terminals, straight insertion direction,
Flange 75 x 75 mm, drill hole spacing 60 x 60 mm.

Order no.	Mennekes order no.	Colour	Weight g
221275	228	red	206
221278	20458	bronze green	221



made
in
Germany

Panel mounted receptacle, angled

With screw terminals, plug-in direction angled by 20°,
flange 100 x 92 mm, drill hole spacing 85 x 77 mm.

Order no.	Mennekes order no.	Colour	Weight g
221270	1485	red	210
221271	24640	bronze green	191



made
in
Germany

PowerTop® plug

With extremely heat resistant contact carrier and nickel-plated contacts, screw fitting and external strain relief.

Order no.	Mennekes order no.	Colour	Weight g
221280	3821	red	295
221281	20454	bronze green	886



made
in
Germany

Safety cap

For waterproof plugs 3821 and 20454.

Order no.	Mennekes order no.	Colour	Weight g
221290	40785	grey	68
221291	40927	bronze green	68



made
in
Germany

PowerTop® coupling receptacle

With extremely heat resistant contact carrier, screw fitting and external strain relief.

Order no.	Mennekes order no.	Colour	Weight g
221285	3881	red	314
221286	20457	bronze green	890



made
in
Germany

HONDA

POWER EQUIPMENT

HONDA EU 20i

Weighing in at just 21 kg, this small current generator is up to 50% lighter than conventional encapsulated power generators in this performance class. Its quiet running and versatility make the EU 20i a real "multi-tool" in its class. Its output of 2 kVA is adequate for operating professional electrical tools such as abrasive cutters, diamond drills etc. The inverter technology of the EU 20i also provides a precise power supply for metrology systems and computers. The Eu 20i is therefore the perfect assistant for fire brigades, aid services and mobile units, who depend on having a power supply at the operation site.

The compact design means that the equipment can also be accommodated in the smallest of operational vehicles.

Because of its soundproofing, it can be used almost anywhere without restrictions.

Even the latest welding units can be operated if two EU 20i devices are connected in parallel.

Technical data:

- Max. output: 2.0 kVA
- Continuous output: 1.6 kVA
- Voltage control: Inverter
- Current strength: 9.7 A
- Protection class: IP23
- Receptacles: 2 x Schuko® 230 V
- DC output: 12 V / 8 A charge current

Motor

- Model: 4-stroke GX100
- Output: 2.6 kW/3.5 PS
- Fuel tank capacity: 4.1 l
- Operating time: 4.0 - 10.5 h
- Sound pressure level: 81 - 90 dB (A)

Other Honda power generators available on request!

Order no.	Dimensions mm	Weight kg
	L x W x H mm	
259251	510 x 290 x 425	21,00



Endress DIN power generator with Duplex technology

ENDRESS power generator compliant with DIN 14685 - the safe, robust helper with hard-wearing quality - for fire brigades, disaster relief organisations and aid services. There are many convincing arguments for the Endress DIN power generators with duplex technology:

- The right power generator for any consumer
- With pioneering quality, technology and equipment
- Brushless, electronically controlled synchronous generator IP54
- VKS technology = non-wearing, contactless, fault-free
- 4-way start-up current. 200% out-of-balance capability

- Simultaneous operation of electronic and inductive consumers possible
- 20,000 generator operating hours, maintenance free
- Duplex-G5 also with speed reduction when idling (optional)
- Motors with OHV technology
- Automatic choke as standard in all models with remote start facility
- Motor protection by means of low oil shut-off
- Connection for refuelling system with all B&S motors as standard
- Protection from overheating using heat deflection plates

Of course, the entire range of Endress power generators is available for delivery. The most interesting products follow as an extract of the overall product range:

ESE 304 HG Duplex

The smallest of the Endress DIN power generators. With robust Honda 1-cylinder 4-stroke OHV motor.

Technical data:

Max. output: [LTP] kVA/kW, 3.5 KVA
 Continuous output: [COP] kVA/kW, 3.0 KVA/2.4 KW
 Nominal voltage: 230 V 1~
 Nominal current: 10,4 A 1~/0,8
 Frequency/protection class: 50 Hz/IP54
 Voltage control: Electronic
 Motor design: 1-cylinder 4-stroke OHV
 Capacity: 196 cm³
 Output: 3000 rpm, 4.3 kW/5.9 PS
 Fuel/fuel tank capacity: Petrol/3.6 litres
 Operating time: With 3/4 load approx. 3 h
 Starting system: Reversing starter
 Sound pressure level: LWA 98 dB(A)
 Sound pressure level: (7 m) 73 dB(A)
 Insulation monitoring: Optionally available

Order no.	Item	Dimensions mm L x W x H mm	Weight kg
218450	ESE 304 HG Duplex	555 x 405 x 445	53,00
218452	Insulation monitoring		
218370	Suitable exhaust hoses 150 cm		1,95
218375	Suitable exhaust hoses 250 cm		2,90

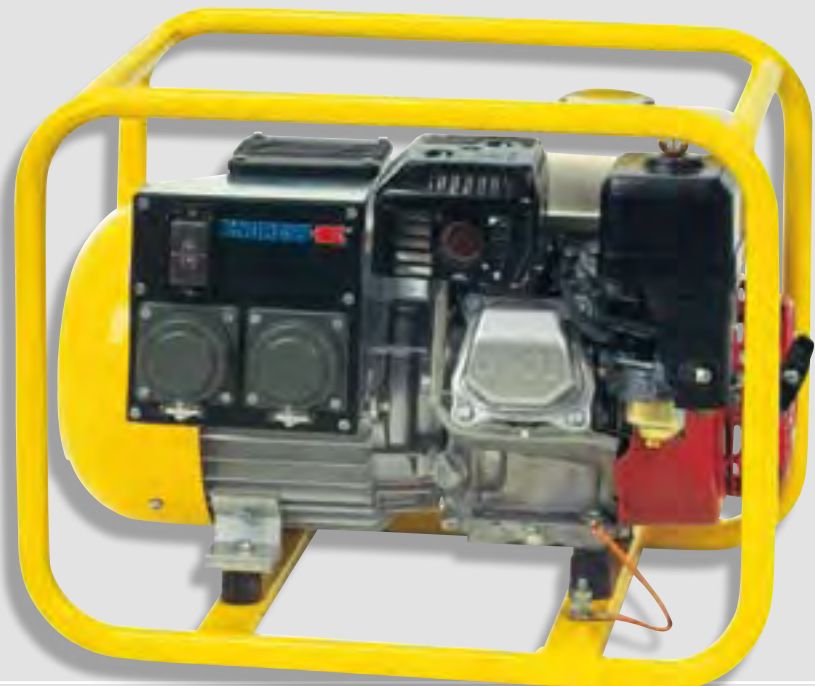

made in Germany

ESE 604 DBG DIN

6.5 kVA power generator with 2-cylinder B&S motor. Meets the highest of demands.

Standard equipment:

- 3 x grounding type receptacle 230 V/16 A, waterproof in acc. with DIN 49442
- 1 x three-phase current CEE receptacle 400/16 A, waterproof in acc. with DIN 49462
- 3 x 2-pole circuit breakers
- Protective conductor test equipment
- ENDRESS load measuring device with 12 V lighting and overload indicator (LED) for out-of-balance
- Changeover to voltage measurement at the push of a button
- Operating hours counter
- Oil monitoring with automatic shut-off
- Diaphragm pump
- Carrying handles with flexible mountings
- Tubular frame, powder coated, Painting: RAL 1012
- On-board tools: 1 toolkit and set of spare parts for motor, 1 test tip and 1 test cable, 1 m in length for protective conductor test equipment

Optional equipment:

- 3-way fuel tap
- Electric start incl. battery (model ESE 604 DBG ES DIN) Remote start facility (ESE 604 DBG ES FS DIN)

Technical data:

Max. output [LTP]:	6.5 kVA
Continuous output [COP]:	6.0 KVA/4.8 kW
Nominal voltage:	230 V 1~/400 V 3~
Nominal current:	18 A 1~/8.7 A 3~/0.8
Frequency/protection class:	50 Hz/IP 54 DIN 40050
Voltage control:	electronic
Motor design:	2-cylinder 4-stroke OHV
Capacity:	480 cm ³
Output:	3000 rpm 7.5 kW/10.2 PS
Fuel/fuel tank capacity:	Petrol/12 litres
Operating time:	with 3/4 load approx. 3.5 h
Starting system:	Reversing starter
Sound pressure level:	LWA 97 dB(A)
Sound pressure level:	(7 m) 72 dB(A)
Insulation monitoring:	optional

Order no.	Item	Dimensions mm L x W x H mm	Weight kg
218454	ESE 604 DBG DIN	700 x 440 x 580	117,00
218456	ESE 604 DBG ES DIN	700 x 440 x 580	123,00
218458	ESE 604 DBG ES FS DIN	700 x 440 x 580	125,00
218460	Refuelling set with 20 l canister		
218452	Insulation monitoring		
218453	3-way tap		
218370	Suitable exhaust hoses 150 cm		1,95
218375	Suitable exhaust hoses 250 cm		2,90



ESE 804 DBG DIN

8.0 kVA power generator with 2-cylinder B&S motor.
Power for any purpose.

Standard equipment:

- 3 x isolated ground receptacle 230 V/16 A, waterproof in acc. with DIN 49442
- 1 x three-phase current CEE receptacle 400/16 A, waterproof in acc. with DIN 49462
- 3 x 2-pole circuit breakers
- Protective conductor test equipment
- ENDRESS load measuring device with 12 V lighting and overload indicator (LED) for out-of-balance
- Changeover to voltage measurement at the push of a button
- Operating hours counter
- Oil monitoring with automatic shut-off
- Diaphragm pump
- Carrying handles with flexible mountings
- Tubular frame, powder coated, painting: RAL 1012
- On-board tools: 1 toolkit and set of spare parts for motor, 1 test tip and 1 test cable, 1 m in length for protective conductor test equipment

Optional equipment:

- 3-way fuel tap
- Electric start incl. battery (model ESE 804 DBG ES DIN) Remote start facility (ESE 804 DBG ES FS DIN)

Technical data:

Max. output [LTP]:	9.0 KVA
Continuous output [COP]:	8.0 KVA/6.4 KW
Nominal voltage:	230 V 1~/400 V 3~
Nominal current:	21.7 A 1~/11.5 A 3~/0.8
Frequency/protection class:	50 Hz/IP 54 DIN 40050
Insulating class/Radio interference level:	F-VDE 0530/N-VDE 0875
Voltage control:	electronic
Motor design:	2-cylinder 4-stroke OHV
Capacity:	480 cm ³
Output:	3000 rpm 10.0 kW/13.5 PS
Fuel/fuel tank capacity:	Petrol/8.5 litres
Operating time:	with 3/4 load approx. 3.5 h
Starting system:	Reversing starter
Sound pressure level:	LWA 97 dB(A)
Sound pressure level:	(7 m) 72 dB(A)

Order no.	Item	Dimensions mm L x W x H mm	Weight kg
218462	ESE 804 DBG DIN	820 x 440 x 580	137,00
218464	ESE 804 DBG ES DIN	820 x 440 x 580	143,00
218466	ESE 804 DBG ES FS DIN	820 x 440 x 580	145,00
218460	Refuelling set with 20 l canister		
218452	Insulation monitoring		
218453	3-way tap		
218370	Suitable exhaust hoses 150 cm		1,95
218375	Suitable exhaust hoses 250 cm		2,90



ESE 1304 DBG ES DIN

Duplex G4 Generator IP54, synchronous, brushless with VKS technology.

Standard equipment:

- 3 x isolated ground receptacle 230 V/16 A, waterproof compliant with DIN 49442,
- 1 x three-phase current CEE receptacle 400/16 A, water tight compliant with DIN 49462,
- 3 x 2-pole circuit breakers
- protective conductor test equipment
- ENDRESS load measuring device with 12 V lighting and overload indicator (LED) for out-of-balance
- Changeover to voltage measurement at the push of a button
- Operating hours counter
- Oil monitoring with automatic shut-off
- Carrying handles with flexible mountings
- Tubular frame/soundproofing hood, powder coated
Painting: RAL 1012
- On-board tools:
1 toolkit and set of spare parts for motor,
1 test tip and 1 test cable,
1 m long for protective conductor test equipment

Optional equipment:

- 3-way fuel tap
- Remote start facility (ESE 1304 DBG ES FS DIN)

Technical data

Max. output [LTP]:	14.3 kVA/11.4 kW
Continuous output [PRP]:	13.0 kVA/10.4 kW
Nominal voltage:	400 V 1~/230 V 3~
Nominal current:	18.8 A 1~/30.4 A 3~/0.8
Frequency/protection class:	50 Hz/IP 54 DIN 40050
Insulating class/	
Radio interference level:	F-VDE 0530/N-VDE 0875
Voltage control:	electronic
Motor design:	2-cylinder 4-stroke OHV
Capacity:	627 cm ³
Output:	3000 rpm, 16.7 kW/22 PS
Fuel/fuel tank	
capacity:	12 litre petrol
Operating time:	with 3/4 load approx. 3,5 h
Starting system:	Electric start incl. battery
Sound pressure level:	LWA 98 dB(A)
Sound pressure level:	(7 m) 73 dB(A)

Order no.	Item	Dimensions mm L x W x H mm	Weight kg
218468	ESE 1304 DBG ES DIN	820 x 440 x 580	154,00
218470	ESE 1304 DBG ES FS DIN	820 x 440 x 580	156,00
218460	Refuelling set with 20 l canister		
218453	3-way tap		
218370	Suitable exhaust hoses 150 cm		1,95
218375	Suitable exhaust hoses 250 cm		2,90



Earthing lead

Ground cable made from copper wire, for earthing, 16 mm², with forked cable shoe for M8 screw.

Order no.	Version	Length m	Weight kg
212302	Loose	10	1,8
212304	Loose	50	9,0
212306	On reel	50	10,4



Earthing spike

Earthing spike made from T-steel, galvanised, approx. 550 mm long. Equipped with four earthing screws and a captive M8 wing nut for securing the earthing lead.

Order no.	Length	Weight kg
212305	550	1,05

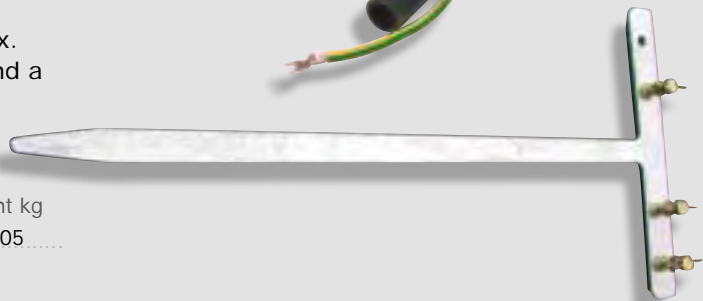

Connecting vice

Vice made from brass, opening width approx. 100 mm, with wing nut.

Order no.	Opening width mm	Weight kg
212307	100	1,05



Magnetic clamp

Magnetic clamp for earthing purposes, with M8 brass earthing screw and wing nut for connection to earthing lead.

Order no.	Weight kg
212309	0,15

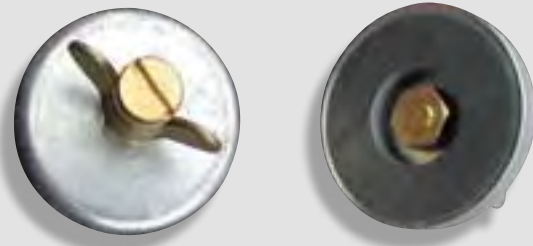

Exhaust hose DIN 14572

Exhaust hoses in acc. with DIN 14572, for connection to power generator, galvanised metal spiral hose with wooden handles for heat insulation.

Order no.	Length cm	Diameter DN mm	Weight kg
218370	150	47	1,95
218375	250	47	2,90
210924	250	80	3,60
210926	250	100	5,10
210928	150	130	4,65





Each operation has its hazards for the emergency services. Good visibility of the emergency services personnel and visible marking and cordoning of the site are therefore vital.

Here you will find everything that you need to provide danger warnings and cordon off sites.



Traffic cones/folding signals

Traffic cone	228	Folding direction boards	231
Folding traffic cone	229-230	Folding signals	231-232



Warning materials

Flags	233	Flashing warning lights	233
Warning triangle	233		



Vests

Warning vest	234	Waistcoats	235
Signal vest	234-235		



Light sticks/ Warning lights

Mini light sticks	236-237	Signal lights	240
Light sticks	237-238	Marshalling sticks	240
LightShapes	239	Strong wind flare set	241



Cordoning materials

Cordoning equipment set	241	Barrier tape	243
Warning tape holder	242	Cordoning chain	243
Sign stand	242	Chalk marking spray	243

Traffic cone, day-glow

This low-cost traffic cone is not BAST-tested and is therefore only for use in corporate and non-public areas. The fluorescent red cone with the white rings has a good warning effect.

Sizes 500 and 700 mm have two white rings, and size 350 mm has one white ring.

Order no.	Size mm	Weight g
218164	350	900
218162	500	1300
218160	750	4300



Traffic cone, reflective

These reflective traffic cones are extremely visible at day and night because of their wide-angle reflection. They correspond to the "TL cones" and have BAST certification 94 3 F 001 and 94 3 S 001.

The heavier weight compared to conventional traffic cones makes the cone extremely stable, even in heavy traffic.

A built-in predetermined breaking point ensures that the body of the cone detaches itself from the heavy cone base when the cone is struck by a vehicle and leaves it on the ground instead of flying through the air.

Advantages:

- Optimised stability
- Safe because of built-in predetermined breaking point
- Stackable, therefore saves space
- Entire surface covered with reflective film

Order no.	Size mm	Weight g
218165	500	2800
218170	750	5800

Folding traffic cone, flashing

Folding traffic cone with integrated light. Exceeds traffic cone requirements. The Pro versions with their dimensions and significantly heavier weight are also approved for fire brigade use.

Features:

- Ideal for car breakdowns and for marking cordoned-off areas and danger areas
- Visible from all directions (360°)
- Simple to use
- Compact and easy to stow away, fits in any boot and beneath car seats
- Lightweight but extremely stable due to extremely low centre of gravity
- Clearly visible reflectors (more than 300 m)
- With integrated, powerful flashing lights for better visibility in the dark or in diffused light
- Flashing facility, water spray protected
- Battery service life more than 300 hours (2 x AAA)
- 5 year guarantee

Scope of delivery:

Folding traffic cone, bulb, PVC carry bag, Batteries (2 x AAA)

Two different versions available in different sizes.

Standard version:

Order no.	Height cm	Collapsed size cm	Weight g
218125	40	25 x 25 x 5	1000
218130	45	25 x 25 x 5	1000
218135	60	30 x 30 x 5	1600
218140	70	33 x 33 x 5	1900



Standard Version extended

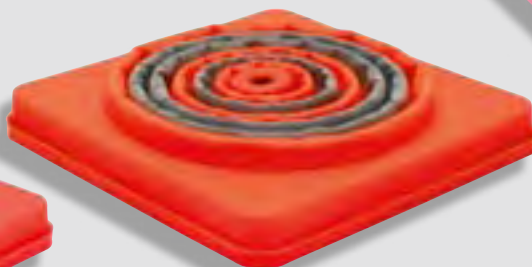

Standard version, collapsed



Pro version:

The Pro versions of the folding traffic cone are characterised by their increased robustness and heavier weight. This means that they are also suitable for heavily used roads and motorways.

Features:

- Has all of the characteristics of the standard folding traffic cone
- More stable because of heavier weight
- Greater stability because of moulded rubber base

Order no.	Height cm	Collapsed size cm	Weight g
218145	50	28 x 28 x 6	1800
218150	75	39 x 39 x 6	3200

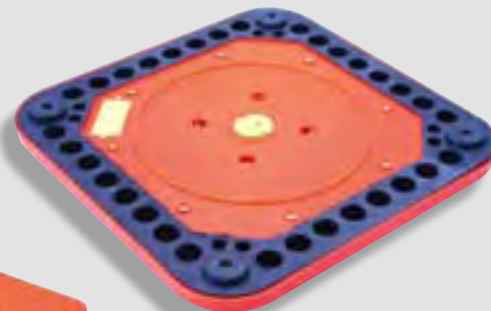

Underside of Pro version base

Folding traffic cone, reflective and flashing

Reflective, folding traffic cone with integrated light. Exceeds traffic cone requirements. Even better visibility in the dark due to the all-over covering of reflective material. The Pro versions with their dimensions and significantly heavier weight are also approved for fire brigade use.

Features:

- Ideal for car breakdowns and for marking cordoned-off areas and danger areas
- Visible from all directions (360°)
- Simple to use
- Compact and easy to stow away, fits in any boot and beneath car seats
- Lightweight but extremely stable due to extremely low centre of gravity
- Reflective all over, visible from a long distance (more than 300 m)
- With integrated, powerful flashing lights for better visibility in the dark or in diffused light
- Flashing facility, water spray protected
- Battery service life more than 300 hours (2 x AAA)
- 5 year guarantee

Scope of delivery:

Folding traffic cone, battery, PVC carry bag, batteries (2 x AAA)

Two different versions available in different sizes.

Standard version:

Order no.	Height cm	Collapsed size cm	Weight g
218136	60	30 x 30 x 5	1600
218141	70	33 x 33 x 5	1900

Pro version:

The Pro versions of the folding traffic cone are characterised by their increased robustness and heavier weight. This means that they are also suitable for heavily used roads and motorways.

Additional features:

- Has all of the characteristics of the standard folding traffic cone, reflective
- More stable because of heavier weight
- Greater stability because of moulded rubber base

Order no.	Height cm	Collapsed size cm	Weight g
218146	50	28 x 28 x 6	1800
218151	75	39 x 39 x 6	3200



Pro version, collapsed

Pro version, extended

Flashing light for folding traffic cone

This add-on flashing light can be put onto any folding traffic cone and enhances visibility and the warning effect. Two LED's, powered by two AA batteries, flash continuously after being switched on.

Features:

- Lamp diameter 4.5 cm
- Threaded battery compartment
- Flashing light 2 x LED 4600 mcd, 20 mA
- Power supply: 2 x AA batteries (included in scope of delivery)

Order no.	Item	Height cm	Weight g
218155	Flashing light, yellow	16	89
218156	Flashing light, red	16	89
218157	Flashing light, blue	16	89



Folding direction boards

The folding direction board is an extremely useful addition to the usual warning materials during operations. It is ideal for cordoning off vehicles that have been involved in accidents and dangerous areas. The extremely sturdy mat made from tarpaulin material has eight suspension eyes and eight powerful magnets at the edge. It is therefore easy to secure in almost any location and on many different surfaces.

The four columns consist of retro-reflective film and each have nine integrated LED's which are extremely bright. The LED's in the waterproof casing are powered by 4 x AA 1.5 V batteries. One set of batteries is adequate for 50 hours of operation.

Once the LED's have been switched on, the columns illuminate in sequence and therefore lead away from the obstruction. This effect is visible from a long way off and provides additional safety at the operation site, not just during the hours of darkness.

Technical data:

Operating modes: sequential, flashing and continuous
Surface material: PVC
Reflection class
Reflector columns: Class I
Switch: water spray protected

Scope of delivery:

1 x Folding direction board
4 x AA 1.5 V batteries
1 x Practical carry bag with reinforced handle and zip fastener

Order no.	Dimensions cm	Weight g
218158	82 x 44	1125



Folding signals with replaceable Hook & Loop signs

The well-tried Dönges folding signals "made by PAX" are also available with replaceable Hook & Loop signs. Advantage: the folding signals can be used in many different areas. Simply affix the sign with the required lettering – done. You are then equipped for any situation with just a single folding signal. The Hook & Loop signs are available with a wide range of standard texts, but can also be printed as per your individual requirements, of course. All Hook & Loop signs are reflective.

Folding signals in luminous colours

Order no.	Item	Height cm	Weight g
218101	Luminous colour	70	3300
218103	Luminous colour	90	3700

Folding signals, reflective

Order no.	Item	Height cm	Weight g
218111	Reflective	70	3900
218113	Reflective	90	5000

Hook & Loop signs, reflective

no illustration.

Order no.	Item	Dimensions cm	Weight g
218109	"FEUERWEHR" overprint	50 x 10	31
218105	"ACCIDENT" overprint	50 x 10	31
218107	"OIL SPILL" overprint	50 x 10	31

other languages
available on request



made
in
Germany

DÖNGES
exclusive

DÖNGES

Folding signal

The high-quality Dönges folding signals "made by PAX®" are characterised by having extremely high quality at low prices.

Both versions have an extremely sturdy frame made from galvanised U-steel with a spring mechanism. An eye for securing an additional weight. A standard pin for mounting flashing lights and a carry handle on the tip of the folding signal are also standard. Both versions can be supplied with two standard overprints.

We can supply an optional adapter for securing the folding signals to the three-leg tripod. This allows the folding signal to be secured to the DIN 14640 standard pin and therefore be mounted at heights of up to 5 m.

Features:

- PAX® plan material for an extremely long service life
- Insensitive to soiling
- Weather-resistant printing in black/red
- Stable because of heavy weight

Two versions in different sizes are available:

Models in luminous colours

	Order no.	Printing	Size mm	Weight g
1	218100	3 x "FEUERWEHR"	700	3300
	218104	"FEUERWEHR/ ACCIDENT/OIL SPILL"	700	3300
	218102	3 x "FEUERWEHR"	900	3700
2	218106	"FEUERWEHR ACCIDENT/OIL SPILL"	900	3700
3	218120	Adapter for standard pin	30 Ø	400

Reflective models

	Order no.	Printing	Size mm	Weight g
	218108	3 x "FEUERWEHR"	700	3900
	218110	"FEUERWEHR/ ACCIDENT/OIL SPILL"	700	3900
	218112	3 x "FEUERWEHR"	900	5000
	218114	"FEUERWEHR/ ACCIDENT/OIL SPILL"	900	5000
3	218120	Adapter for standard pin	30 Ø	400

also in other languages available on request

■ made
■ in
■ Germany

exclusive **DÖNGES**



2 mm thick U-profile



Sturdy spring mechanism



Adapter for standard pin



Warning flag

In acc. with StVZO, white/red/white, wooden stick approx. 80 cm long.

Order no.	Flag dimensions cm	Weight g
212730	50 x 50	160



Warning flag set

Warning flag set for driving in a convoy, consisting of one blue flag, one yellow flag one green flag and one red flag.

Made from cotton, secured to a wooden stick approx. 80 cm in length.

The set is supplied in a sturdy canvas bag.

Order no.	Flag dimensions cm	Weight g
212732	50 x 50	1200

Warning triangle

Sturdy EN version ECE-R27 with test number. Supplied in plastic bag. Extremely reflective.

Order no.	Bag length mm	Weight g
212731	440	1000



Flashing warning lights for vehicle

Flashing warning lights with GGVS/ADR approval, for cordoning accident locations and broken down vehicles. These flashing warning lights are prescribed in accordance with § 53a StVZO for vehicles with a permissible maximum weight of 2.8 t.

The lights can also be used to cordon off GGVS vehicles, with the exception of zone 1 and zone 0.

Both lights are characterised by being extremely stable and easy to use. Powered by five 1.5 V mono cells (D-cells). Batteries not included in scope of delivery.

	Order no.	Dimensions mm	Weight g
1	212836	280 x 105 x 60	650
2	212459	220 x 80 x 55	400
	241014	Battery D/Mono/LR20	140

Warning vest EN 471

The fluorescent orange warning vest provides safety at day and at night in emergency situations when providing assistance.

Available with or without "FEUERWEHR" printed on the back with individual lettering on request.

Features:

- PVC
- Fluorescent orange, visible from a long distance
- Fully reflective strip all round
- Universal fit using fastener at front

Order no.	Printing	Weight g
280002	Without	220
218004	FEUERWEHR	220



Signal vest

Tried and tested many times, this warning vest is used by the fire brigade, the THW, the police, the DLRG, the DRK, the CID and by customs & excise.

In comparison to the standard warning vest, this vest used a higher quality, heavy polyester material. This provides better quality and a longer service life. Another safety factor is achieved by making the warning vest longer, creating a bigger reflective surface and therefore improving the visibility of the emergency services.

The large metal zip fastener allows the vest to be zipped up quickly and easily, even after long periods of use.

The signal vest can also be provided with a customised overprint with individual lettering on request.

Features:

- Warning vest, top quality version similar to the technical directive (TL) or the BMI procurement office.
- 150 g/m² Polyester (100%)
- Fluorescent yellow with fluorescent orange hem
- Two silver reflective strips around the back, one strip over each shoulder ("braces arrangement")
- V-cutout
- Zip fastener at front
- With Hook & Loop fasteners at side for adjusting the size
- Fluorescent orange panel on chest and back
- Incl. protective bag
- Complies with EN 471 cl. 2

Order no.	Printing	Weight g
218006	Without	300
218008	FEUERWEHR	300
218010	THW	300



Individual lettering on request.

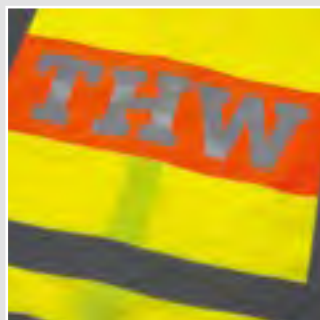

Example printing, customised printing possible

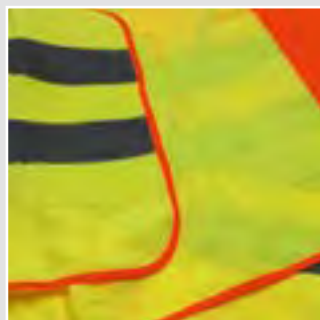

With fluorescent orange hem

PAX

Identification vest Pax®

Emergency services identification vest, available in different colours. Front with holder for two radios and microphone. Wide velvet area on back for two rows of lettering or round emblem. Adjustable size.

Order no.	Colour	Weight g
266046	red	780
266047	blue	780
266048	yellow	780
266049	green	780
266050	grey	780
266051	white	780
266052	lila	780

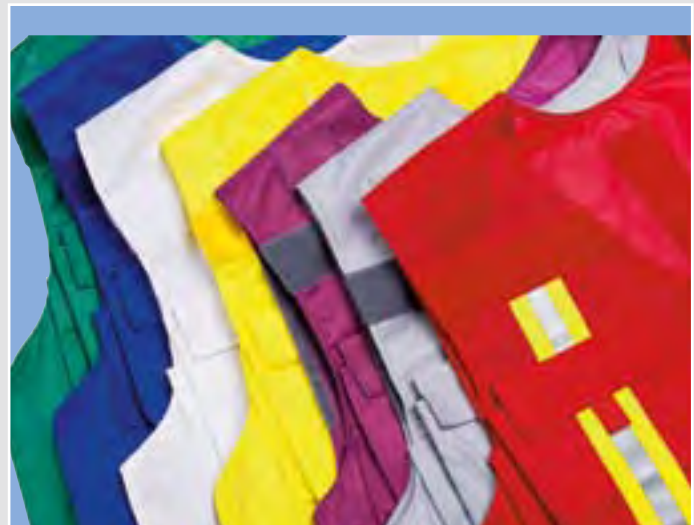

Comfort waistcoat Pax®

Waistcoat with outer pockets for your equipment. Writing materials, tools, torch, mobile phone, radio and much more can be stored in the easily accessible pockets. Reflective material for passive safety and a velvet strip for attaching signs to the back round off this product. Other colours on request.

Order no.	Material	Colour	Weight g
266029	PAX®-Dura	red	850
266030	PAX®-Dura	blue	850
266031	PAX®-Dura	yellow	850
266032	PAX®-Dura	green	850



Example configuration
Supplied without contents



Original Cyalume® ChemLights™

Cyalume® Technologies Inc. from the USA is the world market leader in chemiluminescent light sources, commonly known as light sticks. Cyalume® products are the most popular with users in this area, particularly many armies worldwide. Not least because of this, almost all products have a Nato Stock Number, i.e. they are listed as army equipment with the various Nato partners.

ChemLights™ are already widely used by the fire brigade, the disaster relief organisations, the police, for cordoning off traffic situations, for emergency sea rescues, in industry, in the leisure sector and in many other areas. This is because of the many advantages that ChemLights™ have compared to conventional light sources:

ChemLights™ are safe!

No heat development and no sparks. Any chemicals or gas that are present cannot be ignited. ChemLights are completely non-toxic and non-corrosive.

ChemLights™ are reliable!

ChemLights™ are ready for use at all times. A single manual operation suffices, and you have a visible, bright light over a radius of 360°. Without power supplies, batteries or other power sources. You simply snap the ChemLight™. This breaks a glass capsule inside the plastic housing, and the chemical that it contains mixes with another chemical that is inside the plastic housing. The reaction produces a bright light in different colours depending on the chemicals that are used.

ChemLights™ are bright!

ChemLights™ are visible from long distances in the dark they even operate under water. Depending on the purpose of use, you can choose an extremely bright ChemLight™ with a shorter operating time or a ChemLight™ that is not as bright and operates for up to 12 hours.

ChemLights™ are versatile!

ChemLights™ can be used for many different purposes

- Marking accident locations
- Marking landing sites
- For showing directions
- Personnel safety
- Marking danger zones
- Marking evidence
- Illuminating escape routes
- Triage marking during night operations



ChemLights™ are cost effective!

ChemLights™ do not require any cleaning or maintenance whatsoever no power source is required, and water and wind do not affect the operating time or service life of the lights. ChemLights™ can be stored anywhere – just a single action is required during operations, and you have light!

ChemLights™ are available in different versions, colours and sizes. We can only show a selection of the products here. Other products (particularly special ones for special applications) available on request.

1 Mini ChemLights™ 1 ½"

Small, light and compact. For identification.

Size:

- approx. 4 cm long

Order no.	Light colour	Light duration h	NSN	Weight g
270010	blue	4	6260-01-209-4436	2
270020	green	4	6260-01-209-4434	2
270030	red	4	6260-01-230-8600	2
270040	yellow	4	6260-01-209-4435	2
270050	infrared	3	6260-01-247-0364	2

2 Mini ChemLights™ 2"

Size:

- approx. 5 cm long

Order no.	Light colour	Light duration h	NSN	Weight g
270060	green	4	6260-01-335-2871	3
270070	yellow	4	6260-01-335-2869	3

3 Mini ChemLights™ 3"

Size:

- approx. 8 cm long

Order no.	Light colour	Light duration h	NSN	Weight g
270080	yellow	4	6260-01-335-2870	5

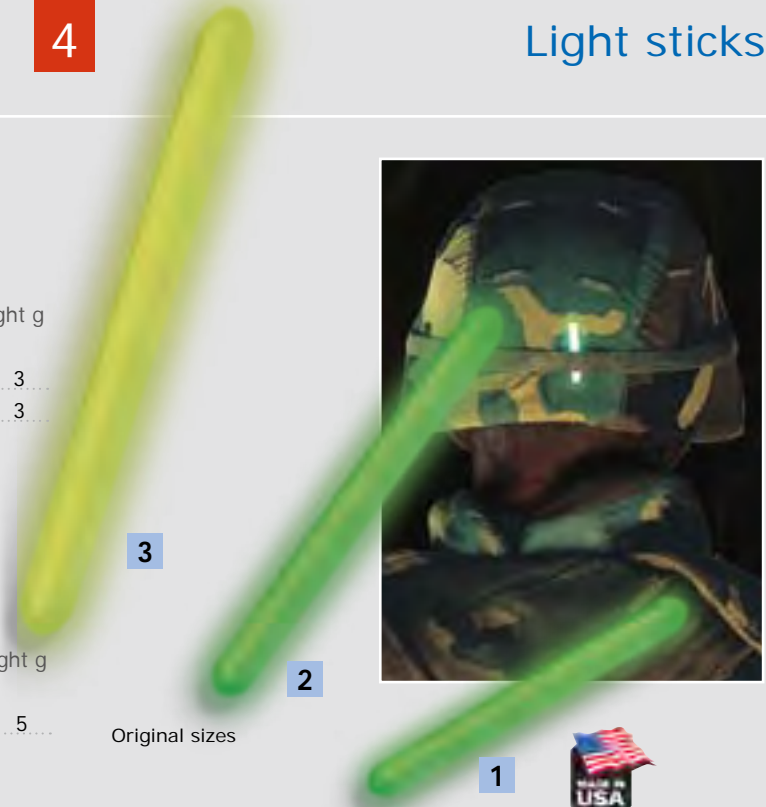

Original sizes

ChemLights™

The standard product. Used by the US Army and many other armed forces. Complies with all military standards. Approved by NATO, also has NATO stock numbers.

ChemLights™ 4"

Size:

- approx. 10 cm long

Order no.	Light colour	Light duration h	NSN	Weight g
270090	green	6	6260-00-106-7478	12
270100	orange	6	6260-01-282-7630	12
270110	infrared	8	6260-01-396-1710	12



ChemLights™ 6"

Size:

- approx. 15 cm long

Order no.	Light colour	Light duration	NSN	Weight g
270120	blue	8 h	6260-01-178-5560	20
270130	blue-Hi	30 min.	6260-01-508-6015	20
270140	green	12 h	6260-01-074-4229	20
270150	green-Hi	30 min.	6260-01-508-6010	20
270160	orange	12 h	6260-01-195-9753	20
270170	orange-Hi	5 min.	6260-01-247-0363	20
270180	red	12 h	6260-01-178-5559	20
270190	red-Hi	30 min.	6260-01-230-8601	20
270200	white	8 h	6260-01-218-5146	20
270210	white-Hi	30 min.	6260-01-247-0368	20
270220	yellow	12 h	6260-01-196-0136	20
270230	yellow-Hi	30 min.	6260-01-074-4230	20
270240	infrared	3 h	6260-01-195-9752	20
270250	infrared	8 h	6260-01-396-1704	20





Only in orange with wire tripod for standing them up



ChemLights™ 10"

Size:

- approx. 25 cm long

Order no.	Light colour	Light duration h	NSN	Weight g
270260	orange	2	6260-01-445-3937	110
270270	yellow	2	6260-01-445-3938	105



ChemLights™ 15", 2 end rings

Size:

- approx. 38 cm long

Order no.	Light colour	Light duration h	NSN	Weight g
270350	blue	8	6260-01-341-8710	90
270360	green	12	6260-01-341-8709	90
270370	red	12	6260-01-341-8712	90
270380	yellow	12	6260-01-341-8711	90
270390	white	8	6260-01-341-8713	90
270400	ultra orange	5	6260-01-341-8715	90
270410	infrared	3	6260-01-341-8714	90

ChemLights™ 15", 1 end ring

Size:

- approx. 38 cm long

Order no.	Light colour	Light duration h	NSN	Weight g
270280	blue	8	6260-01-265-0614	90
270290	green	12	6260-01-247-0362	90
270300	red	12	6260-01-265-0612	90
270310	yellow	12	6260-01-265-0613	90
270320	white	8	6260-01-247-0367	90
270330	infrared	3	6260-01-247-0366	90
270340	infrared	8	6260-01-396-1708	90



With end rings for fastening





LightShapes® 3"

LightShapes® are mainly used for marking. The self-adhesive Light Shapes® can be a lifesaver during operations if they are used to mark the escape route. They are also useful for securing evidence and identifying personnel during operations.

Size:

- approx. 8 cm Ø

Order no.	Light colour	Light duration h	NSN	Weight g
270420	blue	4	6260-01-334-4270	15
270430	green	4	6260-01-311-5086	15
270440	orange	4	6260-01-334-4273	15
270450	red	4	6260-01-334-4272	15
270460	yellow	4	6260-01-334-4271	15
270470	infrared	3	6260-01-311-5085	15
270480	infrared	8	6260-01-396-1705	15



SnapLights™

The industrial product. With almost the same luminance and the same operating time, comparable with the ChemLights™ that are tested in accordance with the highest military standards, SnapLights™ are the alternative for civil applications.

SnapLights™ 6"

Size:

- approx. 15 cm long

Order no.	Colour	Operating time in h	Weight g
270540	green	12	20
270550	red	12	20
270560	yellow	12	20
270570	orange	12	20
270580	white	8	20
270590	blue	8	20

SnapLights™ 10"

Size:

- approx. 25 cm long

Order no.	Colour	Operating time in h	Weight g
270591	green	2	35
270592	red	2	35
270593	yellow	2	35



PML® Personnel Marker Light

The PML® can be secured to clothing using a clip. It was developed for rescue from distress at sea, for example, but is now also used during fire brigade operations for providing the emergency services with better visibility in dense smoke.

Order no.	Light duration h	NSN	Weight g
270594	8	6260-01-086-8077	65

S.O.S.® Signal & Lights

A ChemLight™ with protective sleeve and cord. After activation, the ChemLight™ can be swung round in a circle using the cord in order to convey certain signals. Mainly for maritime use.

Order no.	Light colour	Light duration h	NSN	Weight g
270595	green	8	6260-01-334-4274	45
270596	orange-Hi	5	6260-01-334-6826	45
270597	infrared	3	6260-01-533-1547	45



Warning materials

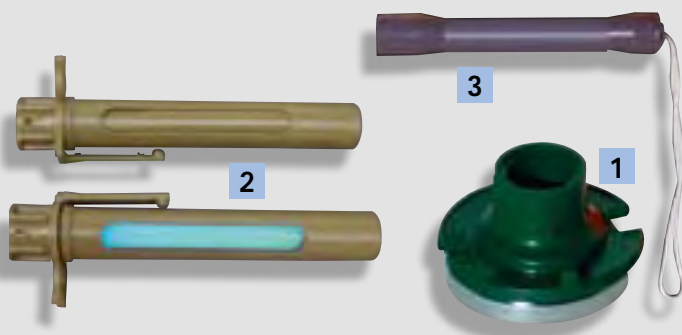

Accessories

Order no.	Name	NSN	Weight g
1 270598	Magnetic foot	6260-01-255-3346	85
2 270599	Tactical sleeve for 6" ChemLights™	6260-01-196-0637	30
3 270581	Handle for ChemLights™	6260-01-255-3345	60

Illuminated marshalling sticks

Originally developed for directing aircraft at civil and military airports, these marshalling sticks are also used by fire brigades and relief organisations as a warning device and for directing vehicles. These illuminated marshalling sticks are the only devices of this kind that are approved by the fire brigade. Supply number 6230-12-368-1588.

Features:

- Extremely light, just 220 grams
- Length 370 mm/diameter 35 mm
- Will not break if dropped - tough plastic
- LED light
- Rubber-covered handle
- Continuous or flashing light
- Light visible from up to 1.5 km
- Up to 400 hours of operation in flashing mode
- Operates using two AA batteries (not included)

Order no.	Colour	Weight g
218003	yellow	220
218016	red	220
241006	Battery AA/Mignon/LR06 (Duracell)	20



Strong wind flare set

Scope of delivery:

- 3 x White magnesium flares
- 3 x Red magnesium flares
- 2 x Wooden flare holders
- 2 x Strong wind matches (pack)
- 1 x Sturdy red canvas bag with closure belt

Order no.	Dimensions mm	Weight kg
212740	660 x 200	3,5



made
in
Germany

DÖNGES
exclusive



Strong wind matches

20 matches in a box.

Order no.	Weight g
212750	24

Dönges cordoning equipment kit

Portable handy complete set that is suitable for any emergency vehicle. The perfect choice, particularly in areas where a limit amount of space is available (such as in cars).

The set was developed in collaboration with the police force. The adjustable holder system allows the length of the spikes (when pushed together) to be reduced to 55 cm. The base also makes the holder suitable for asphalt and concrete.

Contents:

- 1** Sheet metal box 590 x 325 x 235 mm, with carry handles, lockable, painted black with "Absperrgerätesatz" lettering with individual lettering on request, internal partitions for reliably holding all parts
- 2** 10 x feet, galvanised, weatherproof version with fixing screw for secure holder retention. The corners are slightly bevelled in order to provide a secure foothold on pebbles and soil as well.
- 3** 10 x adjustable holders, made from galvanised steel, holders can be extended to a length of up to 105 cm. The spike can be knocked into soil and sand. If the ground is hard, the spike can be inserted into the above-mentioned base. The special holder prevents the warning tape from folding up
- 4** Tool for knocking or pushing the holder into firmer ground without damaging the spike
- 5** Barrier tape, 500 m roll in box, red and white.

Order no.	Tape printing	Weight kg
212800	Neutral	26,0



Individual lettering
on request.

DÖNGES
exclusive

Holder for barrier tape/chain

Galvanised spike, 120 cm long, 12 mm Ø, with fork for barrier tape and cordoning rope. The spike complies with the version required by the THW.



exclusive **DOENGES**

Order no.	THW asset number	Weight kg
212830	5110T22552	1,0



Base for holder

Galvanised, weatherproof version with fixing screw for reliable retention of holders up to 12 mm Ø.

The corners are slightly bevelled in order to provide a secure foothold on pebbles and soil as well.

Order no.	Weight kg
212805	0,8



exclusive **DOENGES**

Sign stand

This sturdy sign stand is used to retain two signs with different size and shape. This allows StVO-compliant warning signs to be combined with information signs.

The base has three legs that can be folded up. This provides a secure foothold, even on uneven surfaces. Two tubes inserted into each other with one fixed and two adjustable mounting brackets ensure that signs of different shapes and sizes can be retained. All parts are painted or galvanised.

With the aid of the reducing adapter the base can be used to erect a cordoning tape holder (order no. 212830) on hard surfaces.

Order no.	Item	Dimensions mm folded up	Weight g
230010	Stand, complete	830 x 100	6700
230012	Base, individual		3800
230014	Reduction piece for holder 212830		40



Height:
min. 80 cm
max. 180 cm

exclusive **DOENGES**

Barrier tape

Quality barrier tape made from strong polyethylene
With vertical red and white stripes on both sides,
light-fast, 80 mm wide, 500 m roll in box.

Order no.	Printing	Weight kg
212814	Neutral	1,5

made
in
Germany



Cordoning chain

Cordoning chain made from plastic, different colour combinations for different purposes.

Order no.	Colour	Length m	Weight kg
212818	red/white	30	1,8
212819	yellow/black	25	1,5

Chalk marking spray

Conventional paint-based markers often leave traces behind for years. The Dönges marking spray contains chalk as the basis for marking.

As a natural substance, the chalk disappears after a while as a result of the weather.

This means that no bothersome marks are left behind when the work is complete.

Marks on asphalt, concrete, soil, grass, wood, sand, gravel, trees etc.

Packing unit: Box containing six cans.

Features:

- Marks on almost any surface
- Approved and catalogued by Deutsche Telekom AG
- Precise spraying by means of special spray head
- Quick-drying material
- Empties completely, since it is an upside-down spray can
- Simple to use - no need to remove cover because of punched-out openings
- Propane/butane propellant
- Free of toxic and carcinogenic substances
- Water hazard classification 0
- Free of heavy metals

Order no.	Capacity ml	Colour	Weight g
217570	400	white	450
217571	400	black	450
217572	400	red	450
217573	400	yellow	450
217574	400	green	450
217575	400	blue	450



made
in
Germany

exclusive **DÖNGES**



Effective and rapid medical first aid for emergency patients and accident victims can save lives. Regardless of whether it is an aid organisation, the fire brigade or the THW - you should be prepared to provide assistance if the worst comes to the worst.



Respiration equipment

Respiration bag	246-248	Laryngoscopes	252-253
Oxygen cylinders	249	Tubes	254-255
Pressure reducer	250	Extraction	255
MANV Oxygen supply	251		



Medical equipment

Pulse oximeter	256-257	AED PRO defibrillator	259-260
Capnometer	258	AED equipment	
AED Plus defibrillator	258	accessories	260-261



Immobilisation

Rescue corset	262-263	Miller board	267
Cervical support	263	Vacuum mattresses	268-269
Spine boards	264-265	Arms and leg splints	270
Spine board accessories	266-267		



Transport

Scoop stretcher	271	Carrying slings	276-277
Carrying chair	271	Patient blankets	278-279
Stretcher	272	Corpse cover	279
Stretcher storage stand	273		
Basket stretcher	274-275		



PAX® products

PAX® materials	280-281	Disaster bag	288
Wasserkuppe		First Aid bags	289
Emergency backpacks	282-285	Inner pockets	290-291
Rescue backpacks	285-287		
High altitude rescue backpack	297		



First Aid equipment

Eyewash bottles	292	First aid kits	294-295
Rescue & clothing scissors	292-293	Fire brigade first aid kit	296
Blood pressure measuring device	294	Emergency backpacks, filled	297-299
Stethoscopes	294	PAX® driver's logbooks	300-301
		Saunders clipboards	302-303

Respiration bag

Product characteristics:

- Completely latex-free: Even minute quantities of latex can cause dangerous swelling of the airways and circulatory problems. In recent years the number of people who are allergic to latex has increased considerably, meaning that every patient is a risk patient.
- Silicone seals and diaphragms: Silicone ensures that the equipment can be used immediately, even after long periods of storage, without the valves sticking. This makes the bag effectively maintenance-free.
- Body made from PVC or silicone (optional): The body consists of special high-quality PVC or silicone. The material does not harden like rubber respiration bags. The roughened outer surface provides a good grip and extremely accurate metering. Easy to operate, even with gloves.
- The respiration bag can be fully dismantled and all parts can be quickly and easily disinfected. All of the most common spare parts can also be supplied individually. The silicone bag is fully autoclavable.
- Pressure limitation valve: Too much pressure when breathing causes damage to the lungs and increases the risk of "stomach breathing". We therefore always supply our respiration bags with an over pressure valve. Too much respiration pressure is prevented. The risk of aspirating the stomach contents is therefore significantly reduced
- Standard mask connection: The connecting cone for the respiration masks is standardised. The bag is therefore compatible with all of the most popular respiration masks.
- Oxygen connection: in order to breathe with 100% oxygen, the bag has an O₂ connection at the air inlet valve
- Comprehensive range of accessories

Adult respiration bag

Features:

- Volume approx. 1,700 ml
- Suitable for patients weighing over 30 kg
- Recommended masks:
 - Size 3 for teenagers
 - Size 4 for adults with a narrow face
 - Size 5 for standard adult

The bag is supplied without a mask.

	Order no.	Volume ml	Material	Weight g
1	251010	1700	PVC	550
2	251011	1700	Silicone	550

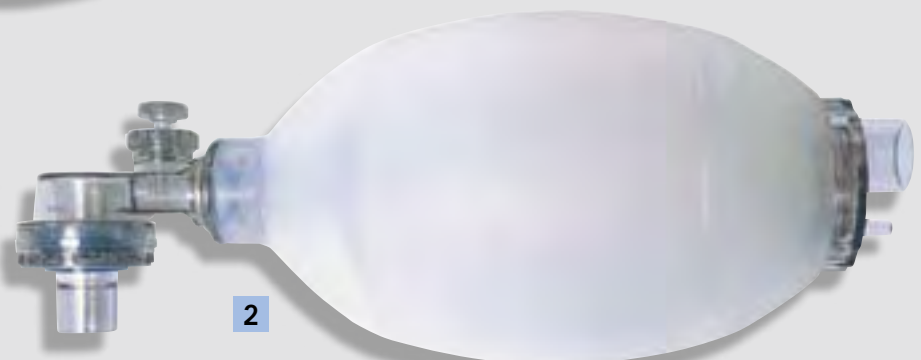

DOENGES
exclusive

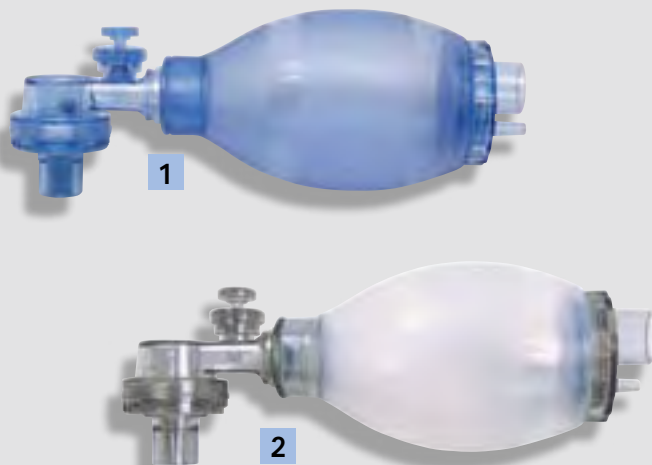

exclusive

Child respiration bag

Features:

- Volume approx. 470 ml
- Suitable for patients weighing approx. 7 to 30 kg
Body weight
- Recommended masks:
Size 1 Small children
Size 2 Schoolchildren
Size 3 Teenagers

The bag is supplied without a mask.

	Order no.	Volume ml	Material	Weight g
1	251020	470	PVC	225
2	251021	470	Silicone	225

PEEP valve

A PEEP (Positive endexpiratory pressure) valve can be connected to the respiration bag to make it possible to provide PEEP respiration.

Features:

- Infinitely variable pressure regulation
- Fully autoclavable
- Compatible with all of the most popular respiration bags PEEP valves are all supplied with three different socket adapters:
ID 30 mm
AD 22 mm/ID 18 mm
AD 22 mm/ID 16 mm

Always remember to order adapter(s) for connecting to the respiration bag.

	Order no.	Colour	Adjusting range	Weight g
1	251032	red	2.5 - 10 cm H ₂ O	50
	251033	blue	5 - 20 cm H ₂ O	50

Adapter for respiration bag

	Order no.	Size	Weight g
	251031	Universal	70



Oxygen reservoir

When an oxygen bottle is connected to the respiration bag, an intake valve with oxygen reservoir must also be used.

The oxygen that continuously flows into the bag is collected and is available during the respiration procedure. No valuable oxygen is lost.

Features:

- Suitable for adult and child bags
- Reusable valve

	Order no.	Size ml	Weight g
	251012	1500	40

Respiration masks

There is a suitable respiration mask for all purposes. All respiration masks have ISO connections and are compatible with all respiration masks.

Air bulb masks

The dome of the mask is made from plastic and retains the shape of the mask. An air-filled cushion seals the contact surface with the face of the patient. Available in two versions without and with valve for adjusting the air cushion.

Features:

- Latex-free
- Transparent
- Anatomical shape
- Easy to use, good seal
- No expensive disinfecting, mask is disposed of after use.



Order no.	Model	Size	Weight g
251211	without valve	1	30
251212	without valve	2	30
251213	without valve	3	40
251214	without valve	4	40
251215	without valve	5	50
251220	with valve	0	30
251221	with valve	1	30
251222	with valve	2	30
251223	with valve	3	40
251224	with valve	4	40
251225	with valve	5	50



Silicone masks

The masks are manufactured in one piece. The contact surface with the patient is made from extremely clingy silicone.

Features:

- Latex-free
- Opaque
- Masks 0, 1, 2 round shape; 3, 4, 5 anatomically shaped
- Good seal provided by soft silicone edges
- Easy to clean and disinfect due to one-piece Design
- Can be re-used several times



Order no.	Size	Weight g
251310	0	80
251311	1	90
251312	2	100
251313	3	100
251314	4	130
251315	5	130



Med oxygen cylinder

Steel cylinder for medical oxygen, compatible with all oxygen equipment and pressure reducers. The cylinders are supplied full of oxygen.

Features:

- Colour white
- Filling pressure 200 bar

	Order no.	Capacity l	Dimensions Ø x length mm	Weight kg
1	252000	1.0	82.5 x 340	1,8
2	252001	2.0	102 x 440	3,8
	252002	5.0	140 x 540	9,0
	252008	10.0	140 x 930	18,0

Aluminium oxygen cylinder

Aluminium cylinders are significantly lighter than steel cylinders, but just as robust. The cylinders are supplied full of oxygen.

Features:

- Colour white
- Filling pressure 200 bar



	Order no.	Capacity l	Dimensions Ø x Length mm	Weight kg
1	252005	2.0	102 x 440	2,5
	252006	5.0	140 x 580	6,5
2	252007	10.0	140 x 1030	11,3

Oxygen supply bag MediOxy

Complete set for oxygen emergencies on the road. Large bag for O₂ cylinder and accessories, fully equipped for emergencies.

Features:

- PAX® MediOxy bag
- 2.0 l oxygen cylinder, filled with medical oxygen
- Adjustable pressure reducer (flow 0 - 15 l/min)
- Oxygen connecting hose 2.1 m
- Oxygen mask for adults
- Respiration mask for adults, incl. oxygen reservoir and size 5 mask

Order no.	Dimensions mm	Weight kg
254610	550 x 250 x 250	8,2



Pressure reducer

The pressure reducers are suitable for all usage areas that involve medical gasses. They are characterised by their ease of use, extremely good reliability and safety, and are easy to maintain.

Fix pressure reducer

Features:

- Fixed flow rate of 6 l/min.
- Pressure gauge for cylinder contents
- Connecting thread 9/16" external thread with 6 mm connecting nozzle

Order no.

252100

Weight g

530

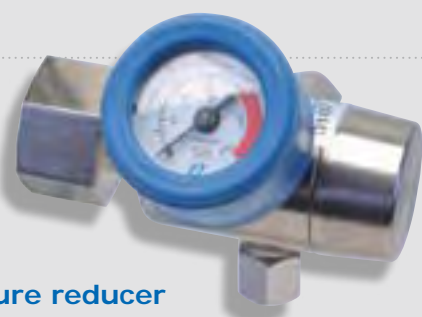

Vari pressure reducer

Features:

- Flow adjustable in stages
0-1-2-3-4-5-6-9-12-15 l/min using handwheel
- Pressure gauge for cylinder contents
- Connecting thread 9/16" external thread with 6 mm connecting nozzle

Order no.

252101

Weight g

790



Flow setting

Vari Plus pressure reducer

As well as having an adjustable flow (0 – 15 l/min), this pressure reducer also has two medium pressure outlets with M12 x 1 screw thread for connecting breathing equipment or demand valves.

Order no.

252102

Weight g

850



Service and maintenance of pressure reducers

The medical product act and the standards for medical pressure reducers (EN 738 in this case) stipulate that it is up to the manufacturer to draw up repair and maintenance instructions for his products and publish them (in the operating instructions). The following applies to the pressure reducers that are described here: The pressure reducers must be subjected to a visual inspection not later than six years after they start to be used, and the inspection must be carried out by the manufacturer or a person who has been trained and authorised by the manufacturer. The safety inspection consists of:

- Leak test under pressure
- Flow accuracy check
- Operating pressure check
- Affixing of a new test sticker

A general overhaul must be carried out after no more than six years after the last safety inspection or twelve years after the product has been brought into circulation, and consists of:

- Leak test under pressure
- Flow accuracy check
- Operating pressure check
- Replacement of diaphragm valve/piston
- Safety valve pressure test
- Affixing of a new test sticker

MANV oxygen box

Mobile oxygen system for setting up an oxygen supply point.

Two 5 l oxygen cylinders are stored in a robust Zarges aluminiumbox, safe for transportation. Pre-installed pressure reducer with quick-release couplings ensure that the equipment can be made quickly operational at any time.

The connection to the removal rail is made using a suitable medium-pressure hose. This means that the removal cylinder can be quickly and safely changed. A 4-way distribution rail with quick-release couplings is available for supplying oxygen.

Controllable flow meters, demand valves or respiration equipment can be operated here as required.

If greater quantities of oxygen are required, additional oxygen bottles can be connected using an additional connection.

Scope of delivery:

- 1 x Zarges box 600 x 400 x 250 mm
- 4 x Tension clamps for securing the cylinder
- 2 x 5.0 l oxygen cylinders, steel, filled
- 2 x Fix pressure reducer
- 1 x Connecting hose between pressure reducer and distribution rail with quick-release coupling
- 1 x 4-way ZGV distribution rail with DIN connections
- 1 x 5 m pressure hose for external feed

Optional:

- 0-15 l min flow meter with quick-release coupling and 6 mm connecting bush

	Order no.	Name	Weight g
1	252105	MANV box	28000
2	252106	Flow meter	400



made in Germany

exclusive **DÖNINGES**



Laryngoscopes

With conventional warm light laryngoscopes the batteries are simply stored in the handle. The voltage supply must be transferred from the handle to the relevant spatula via two small contact plates to power the bulb. Cold light laryngoscopes have considerable advantages compared to the conventional warm light versions:

- The bulb is built into the handle.
- The beam of light is led to the tip of the spatula via a bunch of optical fibres
- Use of halogen bulbs Significant more light output
- No bulb blocking your view at the tip of the spatula
- Cleaning is significantly easier (no edges on spatula to trap dirt)
- No risk to patient from splintering bulb

Stainless steel cold light laryngoscope handle

Top-quality laryngoscope handle made from non-rusting stainless steel. Fully autoclavable. Suitable for all popular cold light spatulas. Matt, slightly corrugated finish for good grip, even with wet gloves.

Features:

- Halogen lamp for extra light
- Corrugated finish
- Handle length 140 mm
- Diameter 28 mm



Order no.	Description	Weight g
251630	Handle	220
251631	Spare lamp	10
241010	Battery C/Baby/LR14 (2 required)	67

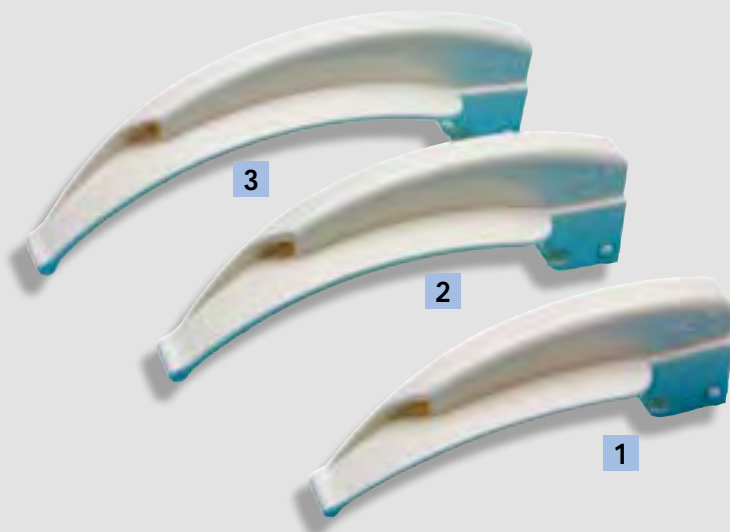

Cold light laryngoscope spatula plastic

The solution for disaster relief organisation emergency equipment easy on the budget. No troublesome preparation after use. The spatulas are simple replaced with new ones. Therefore also ideal for cases with a high risk of infection.

Order no.	Design	Weight g
251640	Miller size 0	15
251641	Miller size 1	15
251642	Miller size 2	20
1 251643	MacIntosh size 2	20
2 251644	MacIntosh size 3	20
3 251645	MacIntosh size 4	20

Stainless steel cold light laryngoscope spatula

Cold light spatula for everyday use. Made from non-rusting stainless steel. Fully autoclavable. Matt finish, therefore less reflection.

Order no.	Design	Weight g
1 251650	Miller size 0	100
2 251651	Miller size 1	100
3 251653	MacIntosh size 2	120
4 251654	MacIntosh size 3	120
5 251655	MacIntosh size 4	130

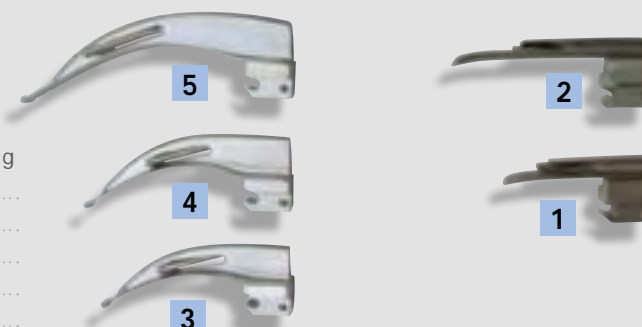



1

Eco cold light laryngoscope set

This set contains one reusable stainless steel handle with batteries and one set of plastic spatulas, depending on purpose of use. All spatulas also available separately, of course.

Components:

Standard set: handle, batteries, MacIntosh spatula Size 2, 3 and 4

Complete set: handle, batteries, Miller spatula sizes 0, 1 and 2 and MacIntosh sizes 2, 3 and 4.

Order no.	Name	Weight g
251620	Standard set	400
1 251621	Complete set	440
241010	Battery C/Baby/LR14 (2 required)	67

Suitable batteries on page 192-193



Stainless steel cold light laryngoscope set

Set as above, but equipped with stainless steel spatula instead of plastic spatula

Components:

Standard set: Handle, batteries, MacIntosh spatula Size 2, 3 and 4

Complete set: Handle, batteries, Miller spatula sizes 0 and 1 and MacIntosh sizes 2, 3 and 4.

Order no.	Name	Weight g
1 251622	Standard set	710
251623	Complete set	910
241010	Battery C/Baby/LR14 (2 required)	67



1

Intubation bag, small

Practical, roll-up bag for intubation utensils. All parts compact and stable, but also well organised. Suitable for many cases, and also as an accessory kit for emergency kits and backpacks. Dimensions 35 x 12 x 8 cm.

Order no.	Colour	Weight g
266084	blue	300



Example configuration
Supplied without contents

Endotracheal tube

with low-pressure collar for emergency intubation

Features:

- For oral and nasal intubation
- Rounded tip with Murphy eye
- 15 mm AD connector
- Disposable product, individually sealed, sterile

Order no.	Size in diam.mm	Weight g
251610	4,0	20
251611	4,5	20
251612	5,0	25
251613	5,5	25
251614	6,0	25
251615	6,5	25
251616	7,0	30
251617	7,5	30
251618	8,0	30
251619	8,5	30

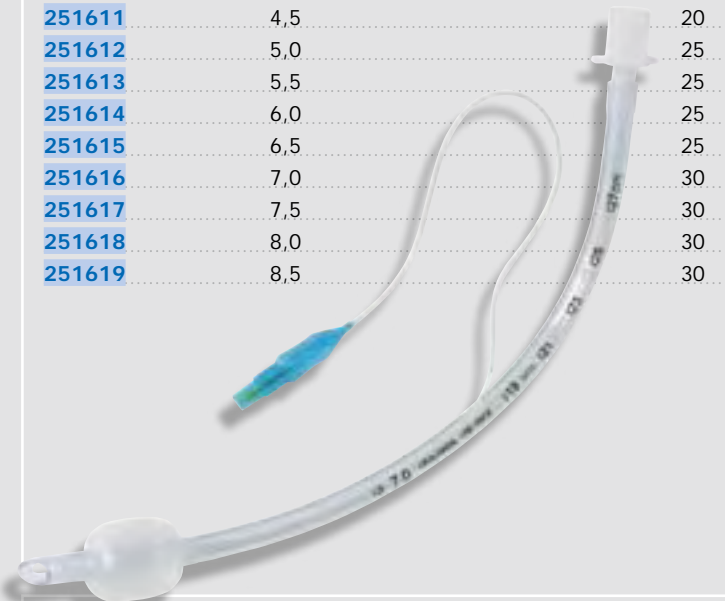

Portex Soft Seal Larynx mask

Features:

- Latex-free
- Soft, thermo-sensitive material for easy positioning
- Clear PVC makes it possible to visually inspect blood, secretion or gastric juice
- Visible condensation for quickly finding the correct position
- Bronchoscope access possible
- Less potential trauma due to built-in blocker line and Soft Seal Cuff
- Disposable product, individually packed, sterile

Order no.	Size	Body weight kg	Weight g
251700	1	- 5	50
251701	1,5	5 - 10	50
251702	2	10 - 20	50
251703	2,5	20 - 30	50
251704	3	30 - 50	50
251705	4	50 - 70	50
251706	5	70 +	50



Guedel tubes

Features:

- Latex-free
- Disposable product, individually packed, sterile
- Material PE
- Colour coded for safe use

Order no.	Size	Colour	Length cm	Weight g
251600	000	pink	4,0	50
251601	00	blue	5,0	50
251602	0	black	6,0	60
251603	1	white	7,0	60
251604	2	green	8,0	70
251605	3	yellow	9,0	70
251606	4	red	10,0	80
251607	5	light blue	11,0	80

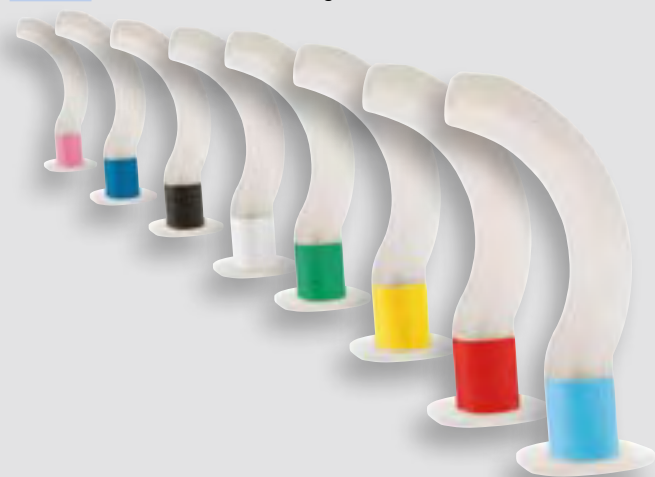

Guedel tube set

set of eight different tubes. Neatly and hygienically packed in transparent dispensing box. A must-have in every emergency kit.

Order no.	Weight g
251608	600



Portable suction pump

Ideal for emergency cases or backpacks. Extremely compact, but also extremely powerful

Features:

- Built-in Hepa bacteria filter
- Integrated overflow protection
- Swivelling secretion container
- Adjustable suction power (50% / 100%)

Technical data:

Vacuum: max. 550 mbar
 Container volume: 350 ml
 Operating temperature: -20° C + 50° C

Scope of delivery:

- 1 x Portable suction pump
- 2 x Yankauer suction catheter, soft
- 1 x Suction container



Order no.	Dimensions mm/Designation	Weight g
253010	160 x 70 x 35	310
253018	Adapter for standard catheter	8,5

Foot-operated suction pump

Secretion suction pump with foot-operated piston mechanism.

Technical data:

Vacuum: max. 400 mbar
 Container volume: 400 ml
 Operating temperature: -20° C + 50° C

Scope of delivery:

Suction pump, secretion container, suction hose



Order no.	Dimensions mm	Weight g
253011	210 x 110 x 190	900

Disposable suction catheter

Suction catheter in different sizes.
 With central opening and two side eyes, straight tip, length 53 cm, colour coded, individually packed, sterile, latex-free.
 Packing unit 50 pcs.

Order no.	Colour	Dimensions Ch	Weight g
253012	green	06	10
253013	blue	08	10
253014	black	10	10
253015	white	12	10
253016	light green	14	10



BCI pulse oximeter

State-of-the-art technology and appealing design are the features of BCI pulse oximeter. Common product features of handheld devices:

- Large, easy to read LED/LCD display
- Extremely easy to operate
- Extremely accurate
- Robust housing
- Compatible with all BCI sensors

**Pulse oximeter BCI 3420Y**

Monitor and sensor in a single unit for rapid display of:

- Oxygen saturation
- Pulse frequency and strength

Display:

SpO₂

Measuring range: 0-99%

Accuracy: +/- 2% with 70 - 99%

Pulse rate

Measuring range: 30 - 254 beats/min.

Accuracy: +/- 2% with 30 - 254 beats/min

Technical data:

Display: Self-illuminating LED display

Power supply: 2 Micro (AAA) batteries (sufficient for 16 h of continuous operation)

Scope of delivery:

- 1 x Pulse oximeter 3420Y
- 1 x Lanyard 3426
- 1 x Operating instructions
- 2 x Alkaline batteries

Order no.	Dimensions mm	Weight g
252531	43.2 x 57.2 x 38.1	85

Pulse oximeter BCI 3401-003**Features:**

- Oxygen saturation
- Pulse frequency and strength
- Heart sound on/off switch

Display:

SpO₂

Measuring range: 0-99 %

Accuracy: +/- 2 % with 70 - 90%

Pulse rate

Measuring range: 30 - 254 beats/min.

Accuracy: +/- 2 % with 30 - 254 beats/min

Technical data:

Memory: Automatic storage of up to 99 patients

Power supply: 4 Mignon batteries (AA) (sufficient for 24 h of continuous operation)

Scope of delivery:

- 1 x Pulse oximeter 3401-003
- 1 x Reusable finger sensor 3044
- 1 x Operating instructions
- 4 x Alkaline batteries
- 1 x Rubber protection sleeve

Order no.	Dimensions mm	Weight g
252510	70 x 168 x 36	369



Pulse oximeter BCI 3402 MiniCorr

The latest technology, handily packed. Also ideal for monitoring small children.

- Precise signal recognition by means of digital measuring technology
- Adjustable alarm limits
- Artefact display indicates erroneous measurements
- Large measurement memory
- PC communication possible
- Can be operated with batteries or power supply

Display:

SpO₂

Measuring range: 0-99%

Accuracy: +/- 2 % with 70 - 99%

Pulse rate

Measuring range: 30 - 254 beats/min.

Accuracy: +/- 2 % with 30 - 254 beats/min

Alarm limits

SpO₂

Measuring range: 50 - 99 % and off

Pulse: 5 - 250 beats/min and off, adjustable average calculation

Technical data:

Memory

Parameters: SpO₂, [pulse rate, pulse strength, relative time

Interval: 4 - 30 sec (variable)

- capacity: 13 h with 4 sec recording interval, 102 h with 30 sec recording interval
- Power supply: 6 Mignon batteries or rechargeable batteries (AA) (sufficient for 24 h of continuous operation)
- Optional: Power supply

Scope of delivery:

- 1 x Pulse oximeter 3402
- 1 x Reusable finger sensor 3044
- 1 x Operating instructions
- 6 x Alkaline batteries

Order no.	Dimensions mm/Designation	Weight g
1 252520	70 x 168 x 36	454
2 252530	Impact protection sleeve for 3402	141
252521	Power supply	110



Accessories for BCI Pulse oximeter

The sensors are original BCI spare parts. The sensors are compatible with all BCI pulse oximeters (except BCI 3420)

Disposable stick-on finger sensors

Sales unit 10 pcs.

Order no.	Application	Model	Weight g
1 252533	Adult >45 kg	1300	10
252534	Children 15-45 kg	1301	10
2 252535	Young children 3-15 kg	1302	10
3 253536	Babies < 3 kg	1303	10



Reusable finger sensors

Order no.	Application	Model	Weight g
1 252537	Standard finger sensor	3044	60
252538	Ear sensor with stirrup piece	3078	50
2 252539	Paediatric finger sensor	3178	50
3 253541	Comfort finger sensor	3444	65
253540	1.5 m extension cable	3311	35



Handheld Capnograph/Pulse oximeter BCI 8400

For comprehensive monitoring, also of intubated patients. Monitoring parameters: ETCO_2 , inspiratory CO_2 , AF, SpO_2 , PF

Features:

- All parameters graphically displayed
- Small, handy device
- With rubber protection sleeve for use by rescue services
- Can be used on intubated and spontaneously breathing patients
- Large display with background lighting
- Adjustable alarm limits
- Battery or mains operated

Display:

SpO_2

Measuring range: 0-100 %

Accuracy: +/- 2 % with 70 - 100%

Pulse rate

Measuring range: 30-254 beats/min.

Accuracy: +/- 2 % with 30-254 beats/min

CO_2

Measuring range: 0-10 % CO_2 STDT

Display range: 0-100 mmHg; 0 - 13.3 kPa

0-10 % CO_2

Respiration rate

Measuring range: 0-150 breaths/min

Accuracy: +/- 1 breath/min

Alarm limits

Physiological: User-selectable high and low limits, adjustable volume, screen indicators

System:

Adjustable volume

Silence:

Temporary 2 min or indefinite (permanent) LED indicator

Technical data:

Power supply: Internal battery or power supply (6 hours with battery operation)

Scope of delivery:

1 x Handheld Capnograph 8400

1 x Reusable finger sensor 3044

1 x Sensor extension cable 3311

1 x Operating instructions

1 x Battery 8408

1 x Battery charger (charging time approx. 2.5 hrs.)

1 x CO_2 patient starter package

Order no.

Dimensions mm

Weight g

252532

127 x 111 x 73

630



ZOLL

Advancing Resuscitation. Today.®

Zoll AED

Sudden cardiac death is the most frequent cause of clinical death.

This happens to approximately 120,000 people in Germany every year. "Automatic External Defibrillators" (AED's) now also put inexperienced people in a position to provide the victim with quick and effective assistance.

CAUSE

The cause of sudden cardiac death (usually referred to as a heart attack) is a heart rhythm defect. The heart stops receiving regular electrical pulses and loses its usual rhythm. The heart starts to fibrillate. Life or death is now a matter of a few minutes. Ensuring that efficient first aid is provided in the initial minutes before professional help arrives is then all the more important.

The AED Plus / AED PRO devices help to reanimate

the heart and lungs and also provide the necessary current pulse to remedy ventricular fibrillation if required.

The AED plus / AED PRO devices provide assistance at all stages for both inexperienced first aiders and professionals

Germany currently lags way behind the USA with a sudden cardiac death survival rate of 3-8%. The highest values are achieved in areas that use AED's that are accessible to the public (so-called Public Access Defibrillation (PAD)).

A cardiac/circulatory collapse can affect anyone at any time, be it at home, at work or in the car, making it all the more necessary to provide efficient first aid in the initial minutes before professional assistance arrives.

In 50% of cases, patients who are apparently healthy are struck down by sudden cardiac death. 80% of all cardiac/circulatory emergencies occur at home.

AED+PLUS® Not just defibrillate, but reanimate

The ZOLL AED Plus is the first comprehensive first aid concept to have been developed for laymen. Early defibrillators have been on the market for some time, but the advanced AED Plus concept, which will guide any layman through a complete reanimation cycle, is new.

- The complete acoustic and visual display of the entire reanimation cycle on the ECG display is new
 - The facility for ensuring that the head is tilted at the correct angle is new
 - The one-piece electrode that will last for five years and provides perfect application is new
- Immediate feedback of the rhythm and strength/depth of the cardiac massage provides proper heart/lung reanimation.

The AED Plus has been specially designed for first aid given by laymen in everyday situations:

Features:

- The first aider is protected by the enclosed first aid package during reanimation
- The first aider is acoustically/visually reminded that professional help should be called
- The head is automatically tilted to the correct angle by the cover of the device
- Unlike other devices with a two-piece electrode, the AED PLUS has a patented ONE-PIECE electrode that provides perfect application and helps the first aider to give the best possible cardiac massage by providing feedback and correcting the rhythm and depth of the compressions

By applying the one-piece electrode the first aider can be certain that the AED PLUS does not just provide him with instructions for everything else after analysing the patient, but ensures that the heart/lung reanimation is carried out properly by means of:

- Audio/visual correction of the strength/depth of the massage and correcting the rhythm
- Respiration instruction: the AED PLUS shows the correct ratio of cardiac massage and respiration
- Analysing the patient
- Defibrillation if required
- Continuing with reanimation if defibrillation is not required - monitored cardiac massage and respiration

A successful all-round lifesaver that takes all eventualities into account for the first aider

Scope of delivery:

AED PLUS, CPR-D electrode, set of batteries and bag

Order no.

259100

Weight g

2600



AEDPRO® The robust professional

A robust structure, specially developed for the needs of professional first aiders. The two-button functionality of the AEDPRO and the intuitive user interface make it easy to use, even by inexperienced first aiders.

The AEDPRO is equipped with a high-resolution display that provides all of the relevant information for defibrillation. The display can also be used for ECG monitoring of a patient using cost-efficient ECG electrodes. This is what makes the AEDPRO so valuable to the user, par-



ticularly if patients that have not been affected by a heart stoppage are being monitored.

The AEDPRO is the only defibrillator that can be used in conjunction with the ZOLL CPR-D electrode, which measures the depth and rhythm of the compressions during HLW. The AEDPRO calculates the compression data of the CPR-D pad and assists the first aider with immediate feedback information.

Features:

- Superior design and additional plastic coating resist even the harshest of weather conditions
- ECG monitoring with 3-channel leakage cable and top quality ECG display
- Manual mode option - specially for professional use
- Unbeatable battery compatibility and options (disposable or rechargeable) depending on user requirements
- Internal memory and USB data memory
- Protection class IP55

Scope of delivery:

AED PLUS, stat•padz electrode and set of batteries

Order no.	Dimensions mm	Weight g
259110	76 x 235 x 239	2900

Accessory for Zoll AED equipment:

CPR stat•padz II

The CPR stat•padz electrode is intended for use with the AED Plus/PRO and manual defibrillators made by ZOLL. Their two-piece design ensures that all treatment facilities are available to the emergency doctor/rescue paramedic. The electrode is designed such that it can be used anterior/anterior or anterior/posterior.

Order no.	Weight g
259111	130



CPR-D•padz

The CPR-D•padz electrode was specially developed for ZOLL AED's. The unique, one-piece electrode design uses the known CPR orientation point for supporting the hands so that the CPR-D•padz electrode can be attached to the patient without delay.

The CPR-D•padz electrode will also last for five years - the longest service life compared to all of the other electrodes that are currently available on the market

Order no.	Weight g
259112	220





Batteries

Please note that the AED Plus may only be used with approved batteries. The set consists of 10 Duracell lithium batteries CR123A.

Order no.	Weight g
259113	400

Wall cabinet

Wall cabinet for storing the AED in areas that are accessible to the public. Prevents theft and abuse by means of visual and acoustic alarm.

The alarm signal is triggered by:

- Opening the doors
- Removing the AED
- Removing the entire cabinet
- Manipulating the electronics
- The operating status of the AED can be checked at any time through the 3mm pane of acrylic glass

Features:

- Cabinet dimensions 402 x 483 x 202 mm
- Galvanised steel plate
- Powder coated



Order no.	Colour	Weight g
259114	white	7500
259115	orange	7500



Information sign

Self-adhesive, luminous sign for identifying AED equipment.

Order no.	Dimensions cm	Weight g
259116	15 x 15	25

Reanimation board

Ideal surface for reanimation. No need for time-consuming relocating from care bed or hospital bed. Makes it possible to perform effective reanimation on soft surfaces such as mattresses. A valuable tool during any other kind of reanimation. The smooth plastic surface and two side handles make quick positioning around the patient possible. The shaped basin ensures that the head is tilted properly.

Order no.	Dimensions cm	Weight g
254014	60 x 40	1400



exclusive **DÖNGES**

Immobilisation



The immobilisation of emergency patients is becoming increasingly important for the fire brigade and the rescue services. Many different systems are used depending on the type of injury.

The cervical support (neck brace) is fitted to relieve and immobilise the patient's cervical vertebrae. The splint creates a solid support between the head and the shoulders.



The rescue corset is used to immobilise patients in locations that are difficult to access. Only the upper body and the head are fixed in position. The system can therefore be fitted when seated (car passengers). The back is supported by sewn-in stays. The corset is fixed to the body using several belts and immobilises the entire spine. The neck should also be supported using a cervical support.



Vacuum splints or vacuum mattresses can be used to immobilise individual extremities or as an independent tool.

These splints are made from a flexible, air impermeable outer material and are filled with small balls and air. This makes the splints extremely flexible and extremely adaptable to the contours of the body. After the splint has been applied, the air is extracted from the splint/mattress using a vacuum pump. The splint therefore hardens in the modelled shape, immobilising the relevant part of the body.



Spine boards are used to completely immobilised injured persons. The spine board is slid beneath the patient, and the injured person is secured to the board using the relevant belt system and a head restraint. The spine board can also be used as a stretcher.

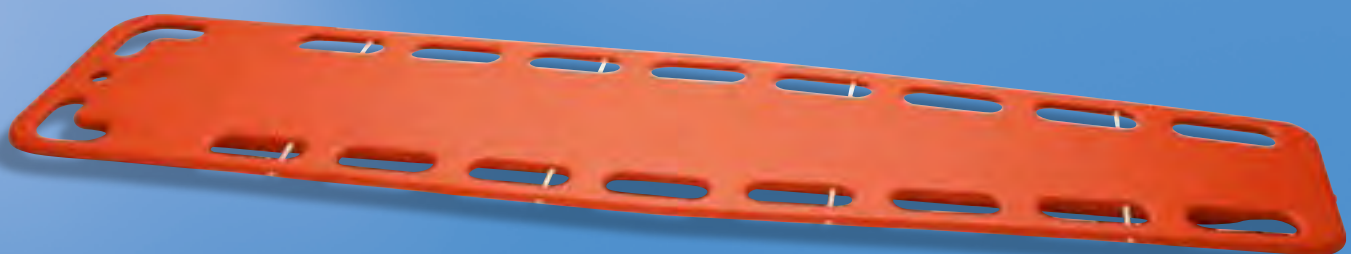

Rescue corset EN 1865

The rescue corset is made from specially coated material. It can therefore be properly wiped clean and disinfected. The smooth surface and the colour-coded belts makes it easier to fit, even under the most difficult of environmental conditions.

Features:

- Colour red
- Load-carrying ability up to 150 kg
- Complete with head padding in emergency bag

Order no.
254019

Weight g
3600



**Adjustable cervical collar
Philly Patriot**

Adjustable cervical supports are now standard in cervical vertebrae immobilisation. Because of the variable height adjustment, the tricky handling of rigid cervical collar is made much easier. It is easy to determine the required height and adjust and fit the cervical collar. The height can also be readjusted afterwards if necessary. The adjustable cervical collar is a replacement for four conventional variants. This saves room in the vehicle and makes it easier to choose which equipment to use.

The Philly Patriot cervical collar has impressive quality and design. The Philly Patriot is available in a version with four-way adjustment for adults and a variant with three-way adjustment for children. Both versions are completely latex-free and, of course, CE-certified and FDA approved.

Features:

- Stable, robust design
- Can be cleaned with mild soapy water
- Adult version with 4-way adjusting facility
- Child version with 3-way adjusting facility

	Order no.	Version	Weight g
1	230100	Adult	125
2	230110	Child	80



Spine board

The spine board is now the most important aid in immobilising patients with spine injuries. We can supply the right board for any purpose:

Spine board EN 1865

This model covers all standard applications in the field of patient rescue.

Additional lateral bars in the handles allow two different strap systems to be used.

The patient can be quickly and safely secured to the board in order to be quickly rescued from the danger area. There are sturdy metal karabiners on the ends of the straps that are clipped to the lateral bars. This makes the board ready for use extremely quickly.

The spider strap system can be used to fully immobilise the patient. The ten straps are secured using Hook & Loop fasteners and can therefore be optimally adapted to the patient.

Features:

- 18 handles around the edges
- Speed Clip pins
- Can be wiped clean and disinfected.
- Complies with the requirements of EN 1865

Technical data:

Dimensions: 183 x 46 x 5 cm
Load capacity: max. 180 kg

Order no.	Item	Weight g
254010	Spinal board	7000
254016	Set with spider strap belt system	7400
254018	Set with speed clip belt system	7750
254013	Set with spider strap and head securing	8500
254022	Set with speed clip and head securing	8650
254025	Spine board protection sleeve from PAX® Plan	800



DOENGES
exclusive

Spine board XXL

Special board for rescuing/recovering heavy persons. This spine board is suitable for operations involving extremely large or heavy persons because of the extremely high load-bearing capacity of 350 kg and the bigger dimensions of the board.

The XXL board is basically supplied with an extra-long spider strap belt system.

Features:

- 20 handles around the edges
- Can be wiped clean and disinfected.

Technical data:

Dimensions: 203 x 51 x 5 cm
Load capacity: max. 350 kg

Order no.	Item	Weight g
254017	Spine board XXL with strap system	9500

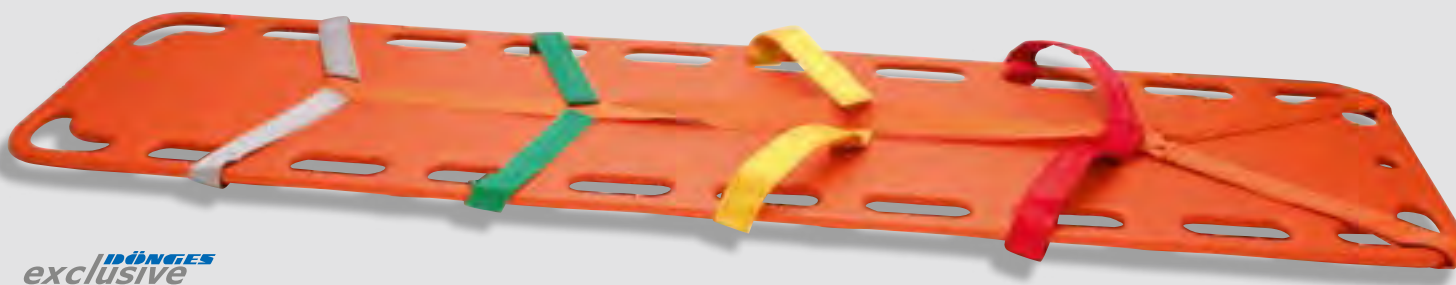

DOENGES
exclusive

Spine board Xtra

The board with the certain "Xtra" For anyone who requires somewhat more from a spine board. The board was developed to achieve maximum x-ray transparency with maximum stability. It is also extremely suitable for water rescues because of its extreme buoyancy in water.

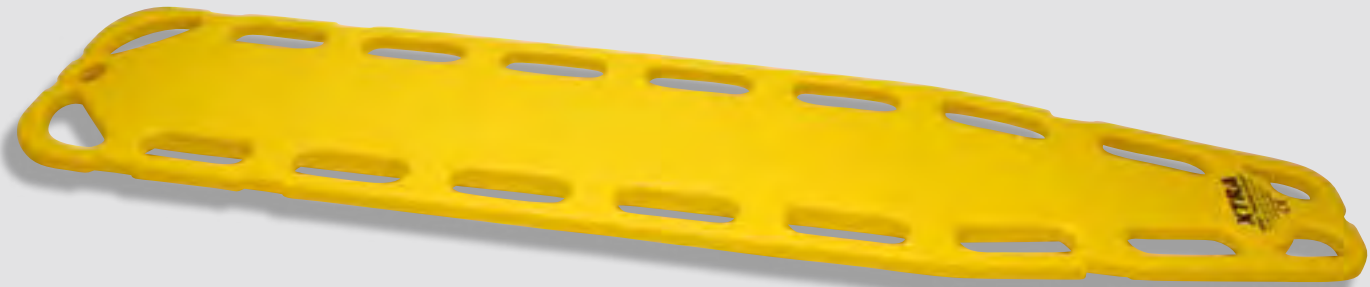

Features:

- 18 handles around the edges
- Transparent to x-rays
- Can be wiped clean and disinfected.

Technical data:

Dimensions: 180 x 40 x 5 cm
Load capacity: 225 kg

Order no.	Item	Weight g
254023	Spine board Xtra	6900
254025	Spine board protection sleeve from PAX® Plan	800

Spine board HDx

One of the first composite spine boards on the market. Unbeaten for functionality and stability for more than 10 years. Extremely flat design makes it easy to slide beneath the patient.



Features:

- 10 handles around the edges
- Speed Clip pins
- Transparent to x-rays
- Can be wiped clean and disinfected.

Technical data:

Dimensions: 183 x 41 x 3.9 cm
Load capacity: 225 kg

Order no.	Item	Weight g
254032	Spine board HDx	6800
254025	Spine board protection sleeve from PAX® Plan	800

Stabilizer spine board

The top-of-the-range spine board. Eleven large handles around the edges allow the spine board to also be carried wearing gloves for long distances. The anatomical shape allows it to be used even in situations where little space is available. Additional openings are provided for attaching the head immobilisation kit.



Features:

- 11 handles around the edges
- Speed Clip pins
- Transparent to x-rays
- Can be wiped clean and disinfected.

Technical data:

Dimensions: 183 x 41 x 5.7 cm
Load capacity: 225 kg

Order no.	Item	Weight g
254030	Spine board Stabilizer	7200
254025	Spine board protection sleeve from PAX® Plan	800

Spider strap system

Strap system for secure immobilisation of patients on a spine board. The colour-coded lateral straps make it easier to fit. The Hook & Loop fasteners allow the straps to be flexibly adapted to the held.

Order no.
254011

Weight g
400



Speedclip belt system

The system consists of three orange belts in a carry bag. The belts are closed in the middle and have sturdy karabiner hooks at the ends. This belt kit is needed wherever the patient needs to be secured to the spine board as quickly as possible.

Order no.
254012

Weight g
750

Speedclip Safe belt system

Belt made from fully washable material. Conventional belts are difficult to clean after being contaminated with blood or vomit. The surface of this belt is completely sealed and cannot be penetrated by fluids. The surface can be simply wiped clean. Extremely suitable for water rescue operations and decontamination operations. The standard version has sturdy metal karabiners at both ends and a plastic buckle. Other versions of the belts available on request.

Order no.
254001
254002

Item
Individual belt
Set with three belts

Weight g
240
720



doenges
exclusive

Head immobiliser

High-quality head immobiliser for attaching to spine board, stretcher or basket stretcher. The immobilising blocks have extra-large openings for the patient's ears. All parts can be wiped clean and disinfected.

Scope of delivery:

- 1 x Base board
- 3 x Securing straps
- 2 x Immobilisation blocks
- 2 x Head/chin immobilisation straps

Order no.

254015

Weight g

1100

DÖNNGES
exclusive

Miller board

The Miller board has been used in rescue operations for more than 20 years. It is particularly used in areas where spine boards can only be used to a limited extent.

- Also for immobilising and recovering patients in extremely tight situations (boats, tunnels, shafts etc.)
- For immobilising aggressive patients
- For immobilising patients that are going to be abseiled down in a basket stretcher

Also excellent for water rescue operations because of its outstanding buoyancy (approx. 120 kg). The board is supplied complete with a special head immobilisation set and retaining straps.

Features:

- Transparent to x-rays
- Can be wiped clean and disinfected.

Technical data:

Dimensions: 167 x 35.5 x 8.2 cm

Order no.

254034

Weight g

6800



Economy vacuum mattress

Vacuum mattress set with optimum price/performance ration.

Mattress made from PVC/nylon fabric and is therefore extremely durable and robust. The surrounding nylon rope makes it easy to work, even if space is restricted. Four patient straps ensure that the patient is securely held.

Scope of delivery:

- 1 x Vacuum mattress
- 1 x Carry bag
- 1 x Aluminium vacuum pump
- 4 x Patient straps

Order no.	Dimensions mm	Bag dimensions mm	Weight g
254207	2000 x 900	860 x 430 x 150	6000



Rotary suction valve



Vacuum mattress EN 1865

The standard model for the rescue service. Made from PVC that can be wiped clean.

Features:

- Rotary valve
- Eight handles at the side
- Two-colour version

Scope of delivery:

- 1 x Vacuum mattress
- 1 x Carry bag
- 1 x Metal vacuum pump
- 4 x Patient straps

Order no.	Dimensions mm	Packing dimensions mm	Weight g
254205	2000 x 1050	860 x 430 x 150	8100



DOENGES
exclusive

Vacuum mattress EN 1865 Comfort

High-quality materials and careful workmanship make this vacuum mattress our top-of-the-range model.

Features:

- Simple to operate using the rotary valve
- Comes with 3 patient straps
- Completely transparent to x-rays
- PVC-coated polyester material
- Underside blue, patient side orange
- Can be used from -20° C to +80° C

Order no.	Dimensions mm	Weight g
254200	2100 x 1000	9000



Rotary valve



DÖNGES
exclusive



DÖNGES
exclusive

Standby bag

bag made from high-quality PAX®-Plan for providing the vacuum mattress with optimum protection during storage and transportation. The suction pump can also be stowed away in the bag.

Order no.	Dimensions mm	Weight g
254202	1100 x 710 x 230	800

Suction pump

High-quality metal pump for providing suction for vacuum mattresses and vacuum splints. Complete with hose and connecting adapter for all popular valves.

Order no.	Weight g
254201	600



DÖNGES
exclusive



Order no.	Item	Weight g
254225	Set	1850
254210	Arm splint	260
254215	Underarm splint	430
254220	Leg splint, adult	700
254221	Leg splint, child	550

Vacuum rails

External material:

PVC-coated nylon, extremely tough, remains flexible at low outside temperatures. Smooth surface, easy to wipe clean and resistant to disinfectant.

Filling:

1-chamber system, filling weight 500 g/m², completely transparent to x-rays, rotary valve

Scope of delivery of set:

- 1 x Arm splint
- 1 x Underarm splint
- 1 x Leg splint
- 1 x Vacuum pump
- 1 x Carry bag



Boston splint

The universal splint for first aid and rescue services
The splint can be individually adapted due to the flexible aluminium core. The foam material coating is blood and fluid-repellent.

Features:

- Versatile
- Easy to manipulate
- Permeable by x-rays
- Can be wiped clean and disinfected.
- Dimensions 91 x 11 cm



Order no.	Weight g
254230	100

Boston splint set

Universal splint set in a practical
Storage bag

Contents:

- 1 x Standard splint 91 x 11 cm
- 1 x Arm splint 48 x 11 cm
- 2 x Finger splints 11 x 2 cm
- 1 x Storage bag



Order no.	Bag dimensions cm	Weight g
254231	17 x 11.5 x 4.5	300

Scoop stretcher EN 1865

The scoop stretcher is used to recover people who have been involved in accidents and may have back or spinal injuries.

It can be separated down the middle and slid beneath the person who is being carried from both sides. The sturdy aluminium version has been tested up to 150 kg. The catches at the separation points are easy to open and can also withstand heavy loads. Of course, the scoop stretcher complies with the requirements of EN 1865.

Scope of delivery:

- 1 x Scoop stretcher
- 3 x Patient straps

Order no.	Dimensions mm folded up	Weight g
254020	1220 x 420 x 95	9000

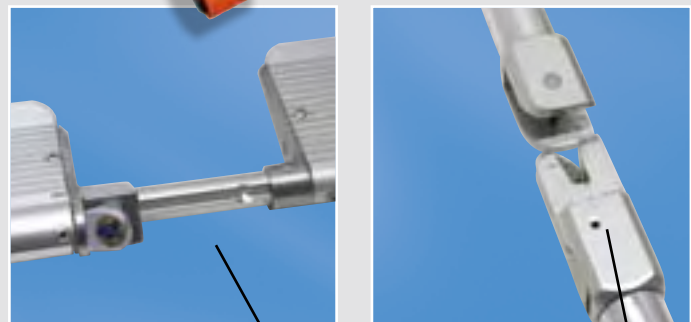

Length adjustment

Catch



DÖNNGES
exclusive

DÖNNGES
exclusive



Carrying chair

Carrying chair with high-quality aluminium frame with four carrying handles and two wheels. Ideal for transporting patients in narrow stairways, lifts and in confined spaces. Seat surfaces made from robust, liquid-repelling artificial fabric.

Features:

- 4 Carrying handles
- 2 Armrests
- 2 Swivelling and lockable wheels
- Automatic locking

Technical data:

Folded out:	91 x 71 x 52 cm
Collapsed:	91 x 19.5 x 52 cm
Load capacity:	150 kg

Scope of delivery:

- 1 x Carrying chair
- 2 x Patient straps

Order no.	Weight g
254026	8500



Stretcher DIN 13024

DIN 13024 stretcher in two different versions: folding once or twice. Covered with robust chemical fibre fabric for quick and easy cleaning and disinfection.

The stretcher can also be supplied with a covering made from liquid-permeable mono-filament fabric. This stretcher is ideal for decontamination equipment.

Frame made from square lightweight metal profile, lockable lateral joints, slide-in carry handles, chest and foot straps with quick-release catch, four sliding feet.



Order no.	Item	Dimensions mm	Weight g collapsed
1	253502 K (folds twice)	1040 x 180 x 145	8500
2	253504 N (folds once)	1920 x 150 x 145	8500
	253508 Carry bag for stretcher K		500
	253506 Carry bag for stretcher N		500
	253514 Carry belt for stretcher (DIN 13044)		200



Tray

Practical tray for storing bandages, treatment implements etc.

Fits on any DIN 13024 stretcher. The tray is simply placed onto the extended carry handles of the stretcher. All stainless steel. With surrounding edge to prevent objects from falling to the ground.

Dimensions: 18 x 55 cm

Load capacity: 25 kg

Order no.	Dimensions cm	Weight g
251029	18x 55	1200



Infusion tripod

For hang up one side of the stretcher. Suitable for stretchers that comply with DIN 13024. Infinitely variable height. Hook for suspending infusion bottles made from stainless steel.

Order no.	Weight g
251030	980



Stretcher storage stand

The stretcher storage stand has been standard equipment at every treatment location for many years. The DIN stretcher is safely placed onto the storage stand, and the patient is at a convenient height for parts. The stable frame is galvanised and is supplied in a painted metal transportation box. The transportation box can also be used as a table top. The stretcher storage stand can therefore be quickly transformed into a table.

Features:

- Sturdy, galvanised frame for maximum stability
- Robust painted metal transportation box
- Max. load-bearing capacity 160 kg
- Max. load-bearing capacity of table top 25 kg
- Package size 1080 x 350 x 120 mm (L x W x H)

Order no.	Assembled dimensions (L x W x H) mm	Weight kg
251040	1140 x 670 x 750	27,5



DÖNGES
exclusive



Storage stand in transportation box.



Can also be used as table.

Basket stretcher

Basket stretchers are used wherever there are problems transporting injured persons using conventional means such as stretchers or carrying chairs. Regardless of whether injured persons are being carried up and down steep, narrow stairs, on scaffolding or building sites, in mines, on boats or in shafts - the basket stretcher is always a useful transportation aid.

Common features:

- Polyethylene tray
- Surrounding aluminium frame
- Four eyes for suspending the abseiling spider
- Surrounding polyamide rope for securing the straps
- Adjustable footrest
- Handles all round for secure grip



Dönges basket stretcher

Features:

- Three patient straps
- Black foam material mattress

Technical data:

Dimensions: 213 x 61 x 18 cm
Load capacity: 200 kg



2

DÖNGES
exclusive

One-piece version

1



Ferno 71FF basket stretcher

Features:

- Four patient straps
- Coated foam material mattress
- Reinforced aluminium frame
- With expansion compensation

Technical data:

Dimensions: 216 x 61 x 19 cm
 Load capacity: 272 kg



Abseiling spider for basket stretchers

Extremely stable version with large, self-locking karabiners.

Colour coded, adjustable straps for quick fitting.

Protective sleeve for basket stretchers

Made from robust Pax®-Plan. Colour red.

For storing and transporting basket stretchers

Order no.	Model	Version	Weight kg
253600	Dönges	one-piece	14,0
2 253601	Dönges	divided	15,0
3 253602	Ferno 71FF	one-piece	13,0
4 253604	Abseiling spider		2,3
253605	Protective sleeve	divided	1,0
253606	Protective sleeve	one-piece	1,1

Dönges carrying sling EN 1865

Anywhere where lack of space or impassable terrain makes the use of a conventional stretcher impossible, the Dönges carrying sling allows injured persons to be transported reliably and safely.

The sturdy nylon fabric with the belt bands sewn around the edges provides load-bearing capacity of up to 150 kg.

The surface coating makes the sling water repellent and impermeable to liquids.

Ten carrying loops ensure that the sling can be securely held, even wearing gloves.

Of course, the sling also complies with the requirements of EN 1865.

For safe storage and easy transportation the carrying sling is provided with a robust stand-by bag. Also meets the requirements of loading standards DIN 14530 and DIN 14555 for fire brigade vehicles.



Technical data:

Material: Coated nylon fabric, washable, impermeable to fluids, 100% x-ray transparent

Colour: Red

Dimensions: Sling 195 x 75 cm

Bag 46 x 29 cm

Load capacity: 150 kg

Order no.

253510

Weight g

2000



exclusive

PAX® carrying sling with foot bag

Carrying sling with sewn-on foot sack. This significantly increases safety during transportation compared to conventional carrying slings.

Technical data:

Material: PAX®-Plan, 100% x-ray transparent

Colour: Red

Dimensions: Sling 200 x 80 cm, with 8 handles

Load capacity: 150 kg

Order no.

253511

Weight g

1500





PAX® Carrying sling XXL

Extremely stable version for recovering heavy persons. The sling is supplied complete with a carry bag. The handles are also reinforced.

Technical data:

Material: PAX®-Plan, 100% x-ray transparent
 Colour: Red
 Dimensions: Sling 200 x 120 cm, with 16 handles
 Load capacity: 250 kg

Order no.

253513

Weight g

3000

Disposable carrying sling EN 1865

The disposable rescue sling (rescue cloth/carrying sling) is an important aid during emergencies. The stable woven tarpaulin is also reinforced with straps in order to maximise the load-bearing capacity of the sling. This sling is EN 1865 certified and therefore also approved for rescuing and recovering patients. Simple wraps must not be used as carrying aids.

Features:

- Double stitched edges
- Cost-efficient
- Compact

Technical data:

Material: Sturdy tarpaulin material with additional reinforcements
 100% transparent for x-rays
 Colour: White
 Dimensions: Sling 185 x 57 cm,
 with 12 handles
 Load capacity: 150 kg



Order no.

253505

Weight g

620

DÖNGES
exclusive



Disposable patient blanket

Fleece blanket for ambulance services, rescue services or disaster relief services

Features:

- Fleece outer, with seams all round
- Interior: layers of pulp material
- Dimensions: 190 x 110 cm
- Summer and winter versions available
- Individually packed in film

Order no.	Version	Weight g
253730	6 layers for summer	320
253731	12 layers for winter	550

Ambulance blanket

The alternative to disposable blankets. Protects the environment and your budget. The use of re-usable ambulance blankets soon pays for itself.

Universal blanket

Features:

- Made from coated jersey material, with fleece inlay
- Extremely light, but still provides good insulation
- Bacteriostatic
- Seams welded all round, 100% waterproof
- Washable at 40°C, quick-drying
- Can be disinfected using normal commercial materials
- Colour: dark blue



Thermal blanket

Features:

- Made from polyester fibre
- Extra-thick fleece inlay (200 g/m²), Extremely good thermal properties
- Bacteriostatic
- Washable at 90° C, suitable for dryers
- Can be disinfected using normal commercial materials
- External colour: dark blue
- Patient side colour: turquoise



Bacteriostatic pillow

Features:

- Made from coated jersey material, Fleece inlay
- Washable at 40° C
- Can be disinfected using normal commercial materials
- Colour: dark blue

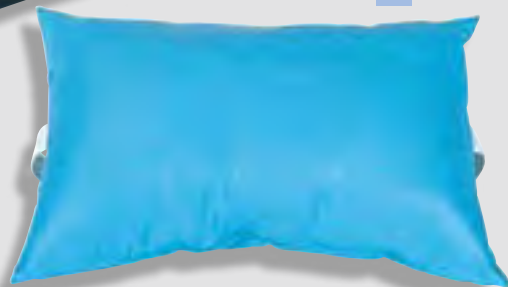

	Order no.	Version	Dimensions cm	Weight g
1	253720	Universal blanket	110 x 190	1000
2	253710	Thermal blanket	120 x 180	1600
3	253715	Pillow	55 x 55	500

Rescue blanket

Gold/silver aluminium-coated. Reflects up to 85% of body heat, can prevent radiation loss, exposure and hypothermia.
Can also be used as a heat shield.

Order no.	Dimensions cm	Weight g
280135	160 x 210	60

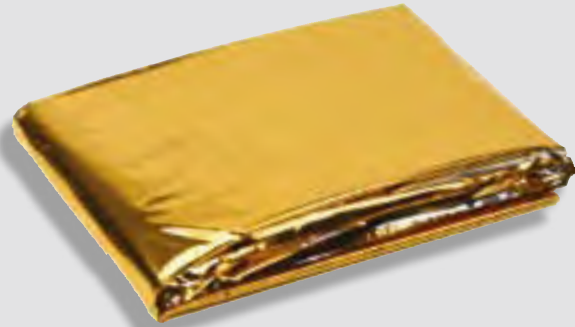

Corpse blanket

Black, strong PE film, with two pairs of PE gloves, packed in plastic bag.

Order no.	Dimensions cm	Weight g
214160	230 x 200	340



DÖNGES
exclusive



Corpse cover

White, non-transparent, with strong zip fastener on three sides, four reinforced carrying handles and two pairs of gloves.

Order no.	Dimensions cm	Weight g
214161	220 x 95	900

DÖNGES
exclusive



standing workmanship and appropriate materials have been used.

How to recognise the original:

- Body with surrounding main reflective strip: good passive safety by means of large reflective surface
- All reflective materials are not sewn on, but stitched in: no tearing off or ripping
- Grey inner areas from PAX®-Plan: beneficial with regard to organisation, cleaning and disinfecting
- Modular design and PAX® organising system: for universal usability of many PAX® products in conjunction with each other



PAX®-Dura classifies materials such as Cordura®

Cordura® is an extremely resilient and durable fabric with a linen-like surface made from polyamide 6.6 (nylon). Cordura® is a registered trademark belonging to chemical giant DuPont.

Fabric is manufactured from DuPont yarns all over the world by selected and continuously monitored textile companies under license.

The quality of this material is not just characterised by its name but mainly by the materials that are used. There are major differences between grades of Cordura® that appear to be the same. That which is ultimately decisive for durability (tear-growth resistance and shearing resistance are the most interesting) is the large quantity of polyamide fibres and the fibre density per square centimetre. The finer a fabric, the lower the denier number. Here too the following applies: anyone who buys from the world's best raw material supplier always has an eye on the quality of the material. It is also possible to obtain low-grade material bearing the name of Cordura®. High-quality Cordura® is impregnated with Teflon on the outside which makes it dirt repellent, and has a double polyurethane coating on the back which makes it waterproof.

Lower quality coatings have other plastics mixed in with them, which usually shorten the service life. The watertightness of a material is always specified in water column millimetres, i.e. a water column of 1000 mm means that a column of water measuring 1 metre can



All of the advantages of the PAX® bags in a nutshell:

- Every PAX® bag is the result of many years of experience and testing that has been carried out in laboratories and everyday situations
- One basic principle applies concerning the material and manufacturing of the PAX® bags: The best is just about good enough
- If you know one, you know them all: The basic models are optimised in terms of fine detail, but are always recognisable as being the same. So that replacements can be reliably obtained years later.
- Perfectionism runs in PAX®'s blood, not just during development. This is the only way to achieve the best price/performance ratio, which Pax® provides with all of its products

All details of a PAX® bag have been tested, checked and thought through. Because of the bag's versatility it adapts to new equipment and demands but does not give way under extreme loads - because it has out-

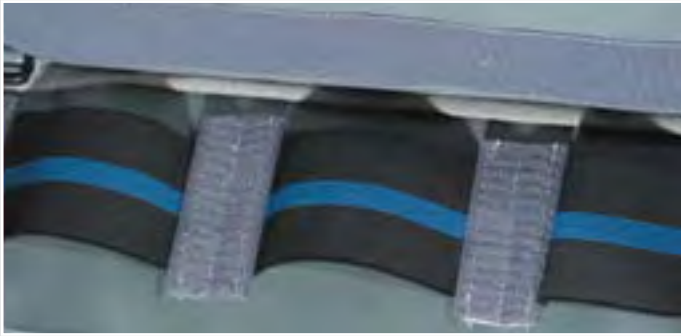

stand on this material but not penetrate it. The seams are the crux of the matter. Whereby water-tightness is often over-rated in the rescue services. Good materials should be manufactured in accordance with the Öko Tex 100 Standard (identifies products that meet the full scope of the human-ecological standard).

PAX®-Plan

PAX®-Plan is a material that was first used by X-CEN-TEK to manufacture backpacks. This is also a coated fabric. The basic structure is comparable to that of the PAX®-Dura. The PAX®-Plan uses a polyester thread that has similar material characteristics to those of the PAX®-Dura, but does not have quite the same resistance capability.



This polyester fabric is provided with several layers of PVC coating. Then this coating is also sealed with a lacquer coating. This lacquer coating then ensures that PAX®-Plan can be easily cleaned and disinfected.

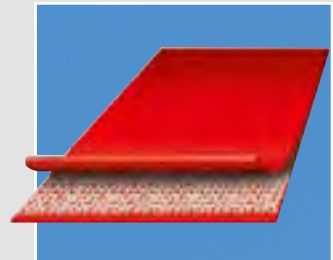

Pax®-Plan

The quality of the PAX®-Plan is mainly characterised by the materials that are used. The combination of the thickness of the coating, the lacquer coating and the connection to the carrier fabric characterise the original PAX®-Plan. Copies cannot usually achieve the excellent characteristics.

PAX®-Plan and all similar materials react to temperature, i.e. they become softer when they are heated and harder when they are cooled, but this does not affect the overall quality of the material. The coating of the PAX®-Plan is usually heavily subjected to the stress of everyday use due to the way in which it is deployed.

In comparison to PAX®-Dura it wears more quickly, particularly in locations that are subjected to stress at particular points. For example, this occurs during removal from case compartments in the ambulance, particularly caused by the "case rail" that is frequently present.

This is seldom required if backpacks are used and should therefore be removed to give the material a longer service life. Good backpacks are reinforced in these typical chafing locations with an extremely durable material that provides the PAX®-Plan with protection.

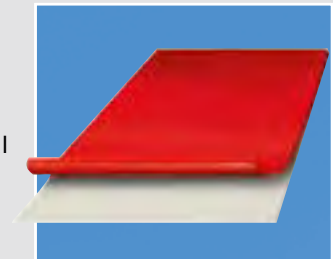

Pax®-Dura

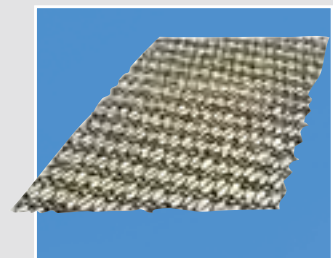

Nylon

Here you will find an extract of our comprehensive PAX® delivery programme. Of course, you can obtain the entire range of PAX® products from us. The majority of products are also available in different colours and for dry suction.

The internals of the Wasserkuppe



Wasserkuppe I

The standard backpack for rescue vehicles. With integral 2-litre oxygen bottle loops, transparent pockets for small materials on the inside, centre partition for intubation and venous access, outer pockets for infusion solutions, small materials and desk pads. Two small side pockets and one large side pocket, one front pocket, All variation options of the Wasserkuppe model series are available to you!

External dimensions: 52 x 62 x 30 cm

Scope of delivery:

- 1 x Backpack
- 1 x Middle wall intubation
- 1 x Inner pocket set 2
- 10 x Easy-Zip-It zip fastener extensions

Order no.	Material	Colour	Weight g
261000	PAX®-Dura	red	4100
261001	PAX®-Dura	blue	4100
261002	PAX®-Plan	red	4300
261003	PAX®-Plan	blue	4300



Wasserkuppe I AED

Wasserkuppe I AED emergency backpack with padded front pocket for all of the most popular AED equipment.

External dimensions: 52 x 62 x 33 cm

Scope of delivery:

- 1 x Backpack
- 1 x Middle wall intubation
- 1 x Inner pocket set 2
- 10 x Easy-Zip-It zip fastener extensions

Order no.	Material	Colour	Weight g
261004	PAX®-Dura	red	4100
261005	PAX®-Dura	blue	4100
261006	PAX®-Plan	red	4400
261007	PAX®-Plan	blue	4400



Wasserkuppe II

Predestined for a 2 backpack system such as "Respiration" and "Trauma". However, also ideal as a first responder backpack on fire brigade vehicles. Suitable for all case compartments because of its compact size. integrated cylinder loops and transparent pockets for small materials inside the body. This model is also available in different colour for differentiation purposes. The inner partitioning and variation options comply with the Wasserkuppe standard. Without outer pockets.

External dimensions: 45 x 62 x 20 cm

Scope of delivery:

- 1 x Backpack
- 1 x Middle wall intubation
- 1 x Inner pocket S
- 2 x Inner pockets M
- 1 x Inner pocket L
- 10 x Easy-Zip-It zip fastener extensions

Order no.	Material	Colour	Weight g
262000	PAX®-Dura	red	3300
262001	PAX®-Dura	blue	3300
263012	PAX®-Plan	red	3600
262003	PAX®-Plan	blue	3600



Wasserkuppe II AED

With enlarged front pocket for an AED device.

External dimensions: 45 x 62 x 33 cm

Scope of delivery:

- 1 x Backpack
- 1 x Middle wall intubation
- 1 x Inner pocket S
- 2 x Inner pockets M
- 1 x Inner pocket L
- 10 x Easy-Zip-It zip fastener extensions

Order no.	Material	Colour	Weight g
263014	PAX®-Dura	red	3900
262005	PAX®-Dura	blue	3900
263013	PAX®-Plan	red	4200
263016	PAX®-Plan	blue	4200



Wasserkuppe III

The trendsetter among emergency backpacks. Used in many situations on water, on land and in the air. With integrated 2 litre oxygen cylinder loops, transparent pockets for small materials on the inside, centre partition for intubation and venous access, outer pockets for infusion solutions, small materials and desk pads. Two small side pockets, one large side pocket and two front pockets. All variation options of the Wasserkuppe model series are available to you!

External dimensions: 52 x 62 x 30 cm

Scope of delivery:

- 1 x Backpack
- 1 x Middle wall intubation
- 2 x Inner pockets S
- 3 x Inner pockets M
- 1 x Inner pocket L
- 1 x Inner pocket KT
- 2 x Inner pockets FT
- 10 x Easy-Zip-It zip fastener extensions

Order no.	Material	Colour	Weight g
263000	PAX®-Dura	red	4100
263001	PAX®-Dura	blue	4100
263002	PAX®-Plan	red	4400
263003	PAX®-Plan	blue	4400



Example configuration
Supplied without contents





Wasserkuppe V

The successful standard backpack has been equipped with the large, adjustable "Tergoflex" walking backpack carrying system in this case. This carrying system allows the backpack to be comfortably carried for a long period. This backpack has 10 more litres of volume than the Wasserkuppe III so that the maximum material configuration that is needed for operations far away from civilisation is available! The internal partitioning is identical to that of the other Wasserkuppe models.

External dimensions: 55 x 70 x 35 cm

Scope of delivery:

- 1 x Backpack
- 1 x Middle wall intubation
- 2 x Inner pockets S
- 3 x Inner pockets M
- 1 x Inner pocket L
- 1 x Inner pocket KT
- 2 x Inner pockets FT
- 10 x Easy-Zip-It zip fastener extensions

Order no.	Material	Colour	Weight g
265000	PAX®-Dura	red	4600
265001	PAX®-Dura	blue	4600
265002	PAX®-Plan	red	5000
265003	PAX®-Plan	blue	5000

Feldberg-First-Aid

Compact emergency backpack with variable partitioning and inner pockets for individual requirements. Designed for the medical services at major events and as an RIT-backpack, this backpack has already proven its functionality many times. You can partition the interior to suit your requirements using a Hook & Loop system!

External dimensions: 40 x 50 x 24 cm

Scope of delivery:

- 1 x Backpack
- 1 x Partitioning system FB
- 2 x Inner pockets S
- 2 x Inner pockets M

Order no.	Material	Colour	Weight g
266000	PAX®-Dura	red	2700
266001	PAX®-Dura	blue	2700
266002	PAX®-Plan	red	3100
266003	PAX®-Plan	blue	3100



Example configuration
Supplied without contents

Feldberg Coronary

Compact emergency backpack with variable partitioning and inner pockets for individual requirements. With additional large front pocket for AED equipment (unlike the other Feldberg models). Designed for the medical services at major events and as standby for coronary sport groups, this backpack has already proven its functionality many times.

External dimensions: 40 x 50 x 35 cm

Scope of delivery:

- 1 x Backpack
- 1 x Partitioning system FB
- 2 x Inner pockets S
- 1 x Inner pocket M

Order no.	Material	Colour	Weight g
266004	PAX®-Dura	red	3400
266005	PAX®-Plan	red	3900



Example configuration
Supplied without contents

Rapid response backpack, large

The large version of this low-cost backpack solution for the RIT-backpack. Inner pockets of different sizes can be attached inside the body using Hook & Loop (comes with three inner pockets!). There is space for documentation and small materials in the cover. There is a Hook & Loop strip on the front for attaching a reflective sign with individual lettering.

External dimensions: 35 x 50 x 17 cm

Scope of delivery:

- 1 x Backpack
- 1 x Inner pocket S
- 1 x Inner pocket M
- 1 x Inner pocket L

Order no.	Material	Colour	Weight g
266008	PAX®-Dura	red	2300
266009	PAX®-Plan	red	2400



Example configuration
Supplied without contents





Example configuration
Supplied without contents

Rapid response backpack, small

Low-cost backpack solution for the rapid response backpack. Inner pockets of different sizes can be attached inside the body using Hook & Loop (comes with three inner pockets!). There is space for documentation and small materials in the cover. There is a Hook & Loop strip on the front for attaching a reflective sign with individual lettering.

External dimensions: 32 x 40 x 17 cm

Scope of delivery:

- 1 x Backpack
- 1 x Inner pocket S
- 1 x Inner pocket M
- 1 x Inner pocket L

Order no.	Material	Colour	Weight g
266006	PAX®-Dura	red	1800
266007	PAX®-Plan	red	1900



Example configuration
Supplied without contents

High altitude rescue backpack Mount McKinley

As a professional mountain rescue backpack, the Mount McKinley provides a carrying system for extreme and long operations. The "V" system made from aluminium stabilisers leads the weight downwards to the padded hip belt, which is made from non-slip PAX®-Grip. Large areas of reflective material on the front and the sides provide excellent visibility, even in the event of sudden fog or heavy downpours. The large front pocket is prepared for karabiners, avalanche shovels and probes. The bottom is made from PAXLon for maximum durability. Colour coded, dimensionally stable inner pockets provide good organisation.

Dimensions: 36 x 65 x 29 cm

Scope of delivery:

- 1 x Backpack
- 1 x Mount McKinley inner pocket set
- 1 x Easy-Zip-It

Order no.	Material	Colour	Weight g
266097	PAX®-Dura	red	2800

Disaster bag

Up to five helpers can autonomously tend to patients with the help of the integrated Kangaroo bag, rapid response waist bags and the basic bag.

Dimensions: 50 x 35 x 35 cm

Scope of delivery:

- 1 x Bag
- 5 x Kangaroo bags
- 2 x Inner pockets

Order no.	Material	Colour	Weight g
266010	PAX®-Plan	red	4200
266011	PAX®-Plan	yellow	4200
266012	PAX®-Plan	green	4200



Example configuration
Supplied without contents

Rapid response Kangaroo bag

Body bag with well-organised partitioning for first aid materials and documentation. Two glove pockets in the stowable lap strap.

Dimensions: 25 x 20 x 12 cm

Order no.	Material	Colour	Weight g
266085	PAX®-Plan	red	700



Example configuration
Supplied without contents

Berlin emergency backpack

Compact emergency backpack with integral front pockets. The front pockets can also be opened from inside the backpack using an internal zip fastener. Oxygen bottle holder, side inner pockets for small materials, rows of loops in the front pockets and an adequate number of inner pockets for individual equipment.

Dimensions: 56 x 38 x 21 cm

Scope of delivery:

- 1 x Backpack
- 2 x Inner pockets S
- 3 x Inner pockets M
- 1 x Inner pocket L
- 10 x Easy-Zip-It zip fastener extensions

Order no.	Material	Colour	Weight g
266095	PAX®-Plan	red	2900
266096	PAX®-Plan	blue	2900



Example configuration
Supplied without contents

First Aid bags

Ideal for use by medical services with lesser first aid materials requirements, and also for use on holiday, on day trips, at sporting events or during private leisure activities.

First Aid bag XS

Small belt bag, can be worn crossways and lengthways with belt loop, for treating minor injuries and other emergency cases, since it will also hold a mobile phone and other similar objects.

Dimensions: 10 x 7 x 4 cm

Order no.	Colour	Weight g
266086	red	80



First Aid bag S

Small, practical first aid bag for on the road with belt loops and surrounding 2-way zip fastener. Internal partitioning with transparent pockets and loops.

Dimensions: 18 x 12.5 x 5.5 cm

Order no.	Colour	Weight g
266087	red	100

First Aid bag M

Practical first aid bag for on the road, on holiday or simple for having something to hand! With belt loops and surrounding 2-way zip fastener. Internal partitioning with transparent pockets and loops.

Dimensions: 24 x 12.5 x 6.5 cm

Order no.	Colour	Weight g
266088	red	150



Example configuration
Supplied without contents



Example configuration
Supplied without contents

First Aid bag L

Bag with replaceable "First Aid" lettering and white cross on a green background. Suitable for filling in acc. with DIN 13157 and extending. With carrying handle, belt loops and shoulder belt. The contents are clearly organised by means of two transparent inner pockets that can also be used as a mini-pack, pockets and loops.

Dimensions: 10 x 20 x 25 cm

Order no.	Colour	Weight g
266089	red	250

Inner pockets

Inner pockets in five different sizes and different colours allow the equipment to be clearly organised.

Inner pocket S

Dimensions:
8 x 8 x 15 cm



Order no.	Colour	Weight g
266060	blue	100
266061	yellow	100
266062	green	100
266063	orange	100
266064	red	100
266065	black	100

Inner pocket M

Dimensions:
8 x 15 x 15 cm



Order no.	Colour	Weight g
266066	blue	100
266067	yellow	100
266068	green	100
266069	orange	100
266070	red	100
266071	black	100

Inner pocket L

Dimensions:
8 x 15 x 30 cm



Order no.	Colour	Weight g
266072	blue	150
266073	yellow	150
266074	green	150
266075	orange	150
266076	red	150
266077	black	150

Inner pocket KT

Dimensions: 8 x 5 x 40 cm



Order no.	Colour	Weight g
266078	blue	150

Inner pocket FT

Dimensions: 8 x 15 x 22 cm



Order no.	Colour	Weight g
266079	yellow	120
266080	green	120

Inner pocket set 1

Scope of delivery:
1 x Inner pocket S, orange
1 x Inner pocket M, red
1 x Inner pocket M, green
1 x Inner pocket L, blue

Order no.	Weight g
266081	500



Inner pocket set 2

Scope of delivery:

- 1 x Inner pocket S, orange
- 1 x Inner pocket S, black
- 1 x Inner pocket M, red
- 1 x Inner pocket M, yellow
- 1 x Inner pocket M, green
- 1 x Inner pocket L, blue

Order no.

266082

Weight g

700



Inner pocket set 3

Scope of delivery:

- 1 x Inner pocket S, orange
- 1 x Inner pocket S, black
- 1 x Inner pocket M, red
- 1 x Inner pocket M, yellow
- 1 x Inner pocket M, green
- 1 x Inner pocket L, blue
- 1 x Inner pocket KT, blue
- 1 x Inner pocket FT, yellow
- 1 x Inner pocket FT, green

Order no.

266083

Weight g

1000



**Easy-Zip-It
Zip fastener extension**

Practical zip fastener extensions do not just make it easier to find the pull tab, but also extend the service life of the zip fasteners. Can be retrofitted to almost any normal commercial zip fastener. A set consists of ten extensions.

Order no.

266091

Colour

yellow

Weight g

10

266092

black

10



Eyewash bottle

Bottle with sterile sodium chloride solution (0.9 %). Equipped with ergonomically shaped eye cup and dust cap. The bottle is suitable for topping up the eye washing station and for individual use.

Order no.	Capacity ml	Weight g
255400	500	540
255401	250	290



Eye washing station in wall box.

Dust-tight wall box with 2 x 500 ml bottles, integrated pictograph and mirror. Particularly suitable for use in workplaces where dust and dirt occur (e.g. workshops). Can be opened quickly and easily when first aid is required.

Order no.	Capacity ml	Weight g
255402	2 x 500	1150

Bandage and clothing scissors

High-quality scissors for cutting bandages and removing clothing.

Features:

- Corrosion resistant
- Autoclavable up to 134° C
- Plastic-covered handle
- Rounded tip
- 19 cm in length

Order no.	Weight g
252264	80



dinges
exclusive

Robin rescue scissors

Rescue scissors in best Solingen quality, guaranteeing a long service life and exact cutting performance at all times, also cuts metal and can be used as an emergency hammer. With wall holder.

Order no.
212497

Weight g
400



made
in
Germany

Forma rescue scissors

The two halves of the scissors can be separated without tools for easier cleaning. The halves of the scissors can also be used individually as knives. The scissor holster can be easily attached using the fixed wall mounting facility for installation in the vehicle. Cuts leather, textiles, thin metal, seat belts and smashes glass.

Features:

- All stainless steel
- Heavy, sturdy version
- Car window smashing facility
- Rounded tips
- Fully autoclavable

Dimensions:

Overall: 230 x 100 mm
Blade length: 83 mm

Scope of delivery:

1 pair scissors
1 x Nylon belt holster
1 x Metal wall and vehicle holder

Order no.
252565

Weight g
540





Blood pressure measuring device

Single-tube blood pressure measuring device for emergency equipment. Large scale for easy readability.

Features:

- Scale diameter 58 mm
- Measuring accuracy in accordance with EN 1060
- Scale 0 - 300 mmHg
- Nylon Hook & Loop cuff (50.8 x 14 cm)
- Child's cuff on request
- Includes bag with zip fastener

Child's cuff

Suitable for blood pressure measuring device described above. Easy to replace for taking measurements on small children.

Order no.	Item	Weight g
252560	RR-device with adult cuff	360
252561	Cuff for children	30

Nurse's stethoscope

Simple stethoscope that is required for intubation and blood pressure measurements.

Dual-head stethoscope

Stethoscope with stainless steel dual head for extended diagnosis of emergency patients. Also suitable for use on children.

	Order no.	Item	Weight g
1	252562	Nurse's stethoscope	50
2	252563	Dual-head stethoscope	90



Vehicle first aid box DIN 13164-B

Vehicle first aid box with DIN 13164 contents. Box made from extremely tough plastic with tabs and hinge.

Order no.	Dimensions mm	Weight g
215068	260 x 170 x 80	800

First Aid case Company first aid box

Sturdy, orange ABS plastic case with fixed internal partitioning and wall holder. The case can be used like a wall cabinet, since the contents do not fall out when the case is opened.

A rubber seal protects the contents from dust and moisture.

DIN 13157-C (small company first aid box)

Order no.	Dimensions mm	Weight g
1 215066	280 x 190 x 110	1700

DIN 13169-E (large company first aid box)

Order no.	Dimensions mm	Weight g
2 215067	450 x 330 x 165	3800



1



2



First aid kit DIN 14142-K

First aid materials in accordance with DIN 14142:2005-07 in **Dönges Firebox®** made by Zarges in accordance with DIN 14880-4-LM (400 x 300 x 150 mm) with partitioning and "Verbandkasten K DIN 14142" lettering with individual lettering on request.

Contents:

- 2 x Rolls of sticking plaster
- 2 x First aid dressings
- 10 x Fingertip dressings
- 10 x Finger dressings
- 20 x Plasters
- 12 x Small dressing packs
- 12 x Compresses
- 8 x Sterile gauze
- 4 x Rescue blankets
- 9 x Gauze bandages
- 20 x Sticking plaster
- 4 x Net bandage
- 4 x Triangular bandages
- 2 x Bandage scissors
- 4 x Eye compresses
- 1 x First Aid brochure
- 20 x Non-woven fabric bandage
- 4 x Minigrip bag
- 12 x Disposable gloves
- 1 x Notepad

Individual lettering on request.



Order no.	Item	Weight g
218500	Kit, complete	5300
214035	Box DIN 14880-4-LM-S empty	3800
218505	Loose contents (as spare)	1500

made in Germany



exclusive **DÖNGES**



Fire brigade emergency backpack DIN 14142-K

Contents of fire brigade first aid kit stored in a PAX® emergency backpack. Ideal if little room is available. Inner pockets of different sizes can be attached inside the body using Hook & Loop (comes with three inner pockets!). There is space for documentation and small materials in the cover. There is a Hook & Loop strip on the front for attaching a reflective sign with individual lettering. Backpack made from PAX®-Plan that can be wiped clean.

Contents distributed in one size M inner pocket, one size L inner pocket and one size S inner pocket.

Technical data:

Material: PAX®-Plan, red
Dimensions: 32 x 40 x 17 cm

Contents:

- 2 x Rolls of sticking plaster
- 2 x First aid dressings
- 10 x Fingertip dressings
- 10 x Finger dressings
- 20 x Plasters
- 12 x Small dressing packs
- 12 x Compresses
- 8 x Sterile gauze
- 4 x Rescue blankets
- 9 x Gauze bandages
- 20 x Sticking plaster
- 4 x Net bandage
- 4 x Triangular bandages
- 2 x First aid scissors
- 4 x Eye compresses
- 1 x First Aid brochure
- 20 x Non-woven fabric bandages
- 4 x Minigrip bag
- 12 x Disposable gloves
- 1 x Notepad

Order no.	Item	Weight g
218501	Backpack, complete	3300
218505	Loose contents (as spare)	1500



exclusive **DÖNNGES**

Emergency backpack DIN 13155

Compact emergency backpack with DIN 13155 contents. Full range of equipment for advanced first aid. The enlarged dimensions of the backpack means that the entire DIN 13155 contents can be neatly stowed away. Inner pockets of different sizes can be attached in the body using Hook & Loop, and there is room in the cover for documentation and small items. There is a Hook & Loop strip on the front for attaching a reflective sign with individual lettering. Backpack made from PAX®-Plan.

Contents distributed in one size M inner pocket, one size L inner pocket and one size S inner pocket.

Dimensions: 35 x 50 x 17 cm

Contents:

- 1 x Respiration bags
- 3 x Respiration masks (size 3, 4, 5)
- 3 x Guedel tubes
- 1 x Handheld suction pump
- 6 x Suction catheter
- 1 x Blood pressure measuring device
- 1 x Stethoscope
- 1 x Diagnostic light
- 1 x Hand disinfectant 100ml
- 2 x Universal splints
- 1 x First aid kit in acc. with DIN 13155

Order no.	Material	Colour	Weight kg
259004	PAX®-Plan	red	6,0



Emergency backpack DIN 13155 First Responder

Designed for the medical services at major events and as an RIT-backpack, this backpack has already proven its functionality many times. You can partition the interior to suit your requirements using a Hook & Loop system! Already equipped with DIN 13155 contents, this backpack provides adequate room for additional equipment in accordance with individual user requirements.

Dimensions: 40 x 50 x 24 cm

Contents:

- 1 x "FB-S" partition set
- 2 x Inner pockets M
- 2 x Inner pockets S
- 1 x First aid kit in acc. with DIN 13155

Order no.	Material	Colour	Weight kg
269006	PAX®-Plan	red	6,8

Emergency backpack DIN 13155 First Responder Coronary

Same equipment and contents as the First Responder, but with additional front pocket for an AED device.

Dimensions: 40 x 50 x 35 cm

Contents:

- 1 x "FB-S" partition set
- 2 x Inner pockets S
- 2 x Inner pockets M
- 1 x First aid kit in acc. with DIN 13155

Order no.	Material	Colour	Weight kg
269007	PAX®-Plan	red	7,6



exclusive **DOENGES**

exclusive **DOENGES**

Emergency backpack DIN 13155 First Responder O₂

Original PAX Wasserkuppe III with DIN 13155 contents. The absolute trendsetter among emergency backpacks with DIN 13155 equipment and an oxygen supply add-on kit consisting of one 2.0 l oxygen cylinder, an adjustable pressure reducer (0 - 15 l/min) and an oxygen mask.

Because of its generous dimensions and additional inner and side pockets, the backpack has plenty of room for storing additional equipment.

Dimensions: 52 x 62 x 30 cm

Contents:

- 9 x Inner pockets, centre partition intubation/venous access and O₂ holder
- 1 x Oxygen cylinder 2.0 l
- 1 x Pressure reducer (flow 0 - 15 l/min)
- 1 x Oxygen mask
- 1 x First aid kit in acc. with DIN 13155

Order no.	Material	Colour	Weight kg
269008	PAX®-Plan	red	10,0



DÖNGES
exclusive



NRW disaster relief emergency backpack

The standard backpack used by the emergency relief services in North Rhine Westphalia. Top quality PAX Wasserkuppe III with small ampoule kit and contents in accordance with DIN 13155 with comprehensive range of extras.

Constituent of vehicle contents of GW-SAN 25 model NRW.

Dimensions: 52 x 62 x 30 cm

Contents:

- 1 x Small ampoule kit,
- 1 x Inner pocket set, centre partition intubation/venous access and O₂ holder
- 1 x Adult respiration bag incl. O₂ supply
- 1 x Child respiration bag incl. O₂ supply
- 4 x Respiration bags size 2, 3, 4, 5
- 1 x Oxygen cylinder 2.0 l
- 1 x Pressure reducer (flow 0 - 15 l/min)
- 1 x Oxygen mask
- 3 x Guedel tubes
- 1 x Handheld suction pump
- 6 x Suction catheter
- 2 x Cold light laryngoscope handles, stainless steel, incl. Batteries
- 1 set of cold light intubation spatulas (Miller size 0, 1, Mac 2, 3, 4)
- 1 Set of endoscope tubes (8 pcs.)
- 1 x Blood pressure measuring device
- 1 x Child's cuff for blood pressure measuring device
- 1 x Stethoscope
- 1 x Diagnostic light
- 3 x Winged needle infusion set
- 1 x Infusion device, pressurised
- 1 x Tourniquet
- 1 x Bandage and clothing scissors
- 1 x Hand disinfectant 100 ml
- 2 x Universal splints
- 1 x First aid kit in acc. with DIN 13155

Order no.	Material	Colour	Weight kg
259009	PAX®-Plan	red	23



DÖNGES
exclusive



Example configuration
Supplied without contents

Driver's logbook A4 portrait

The DIN A5 format vehicle folder. Everything can be put into well-organised storage in here, including comprehensive documentation and map materials. With key clip.

Order no.	Material	Colour	Weight g
266013	Nylon	red	750
266014	Nylon	blue	750
266015	Nylon	black	750

Driver's logbook A5 portrait

DIN A5 driver's logbook in portrait format for documentation, vehicle documents and much more. Ring binder mechanism. With key clip.

Order no.	Material	Colour	Weight g
266016	Nylon	red	350
266017	Nylon	blue	350
266018	Nylon	black	350



Driver's logbook A5 landscape

DIN A5 driver's logbook in landscape format for documentation, vehicle documents and much more. Ring binder mechanism. With key clip.

Order no.	Material	Colour	Weight g
266019	Nylon	red	350
266020	Nylon	blue	350
266021	Nylon	black	350



Example configuration
Supplied without contents

Driver's logbook Multi-Organizer

Document folder in DIN A4 format in PAX®-Plan. A large number of pockets and a clipboard that can be attached using Hook & Loop extend the range of applications as far as doing the paperwork for a major accident! Includes detachable plastic clipboard and key clip.

Order no.	Material	Colour	Weight g
266022	PAX®-Plan	red	1000
266023	PAX®-Plan	blue	1000
266024	PAX®-Plan	black	1000



Example configuration
Supplied without contents



Saunders Clipboards

Saunders has been manufacturing top quality clipboards and form holders made of aluminium for more than 60 years. The wide range of versions means that the majority of organisation problems can be solved.

Redi Rite

This Saunders clipboard consists of a writing board on a cassette. This version is the ideal solution if you need to carry forms, require a good writing surface and also want to work purposefully. Opens at the bottom.

Order no.	Model	Dimensions mm	Weight g
255510	RR8512	216 x 305	832

Model A

The Saunders form holder is versatile, practical and easy to use! Can be used by both right-handers and left-handers. It is suitable for forms in portrait and landscape format. The writing boards provides a writing surface that is robust and easy to write on. The storage compartment at the bottom protects completed forms and keeps them safe and dry. Opens at the top.

Order no.	Model	Dimensions mm	Weight g
255511	AH8513	216 x 330	802

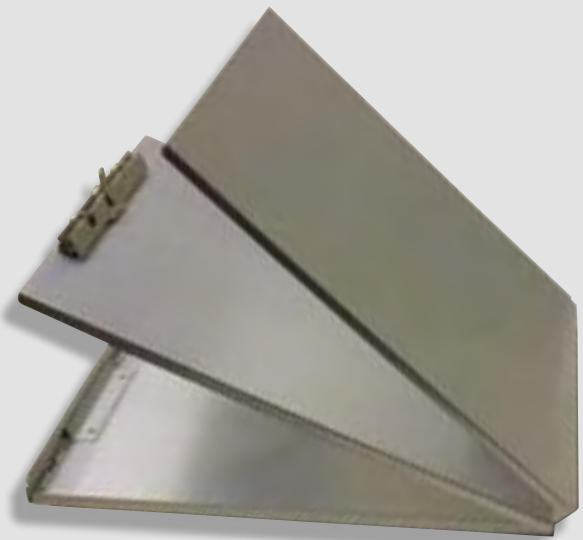
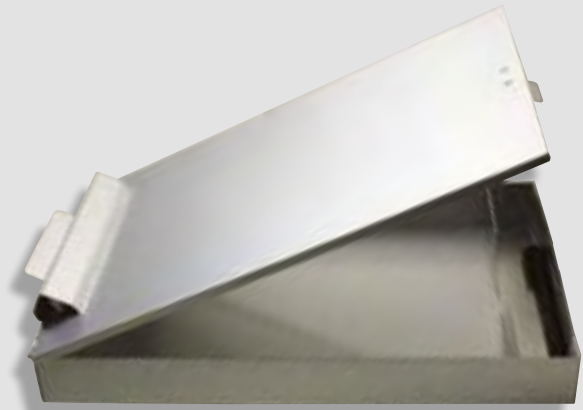

Cruiser Mate / Tuff-Writer

The "Cruiser mate" stores all of your forms in a convenient and well-organised way. The two integral storage compartments allow you to organise your documents more easily. The intermediate panel inside can be removed, creating a large inner compartment. Opens at the bottom.

The "Tuff-Writer" is the side-opening version of the popular "Saunders Cruiser Mate". It is extremely practical if little space is available. The "Tuff-Writer" is handled like a book. It is equipped like the "Cruiser Mate" and also has a compartment for pens.

	Order no.	Model	Dimensions mm	Weight g
1	255512	CM8512	216 x 305	1056
2	255514	TW8512	216 x 305	1056

Snapak

The "Snapak" - a book when open, a cassette when closed. This extremely popular sheet holder can be used for loose forms, sets of forms or sales ledgers. As well as a clip for securing your forms there is also an adjustable aluminium strip for keeping them in place. The Snapak can be closed, creating a handy cassette for protecting your forms. Opens at the side.

Order no.	Model	Dimensions mm	Weight g
255513	SN8512	216 x 305	822

Clipboard KK

A prize-winning clamping device is what makes this board so unique. The large standard clamp keeps your forms securely in place. The board is compact and therefore ideal for carrying around. It is made from robust lightweight aluminium.

Order no.	Dimensions mm	Weight g
255517	216 x 305	530

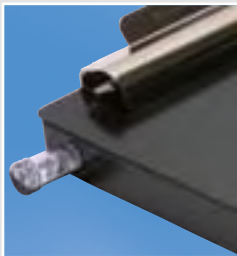
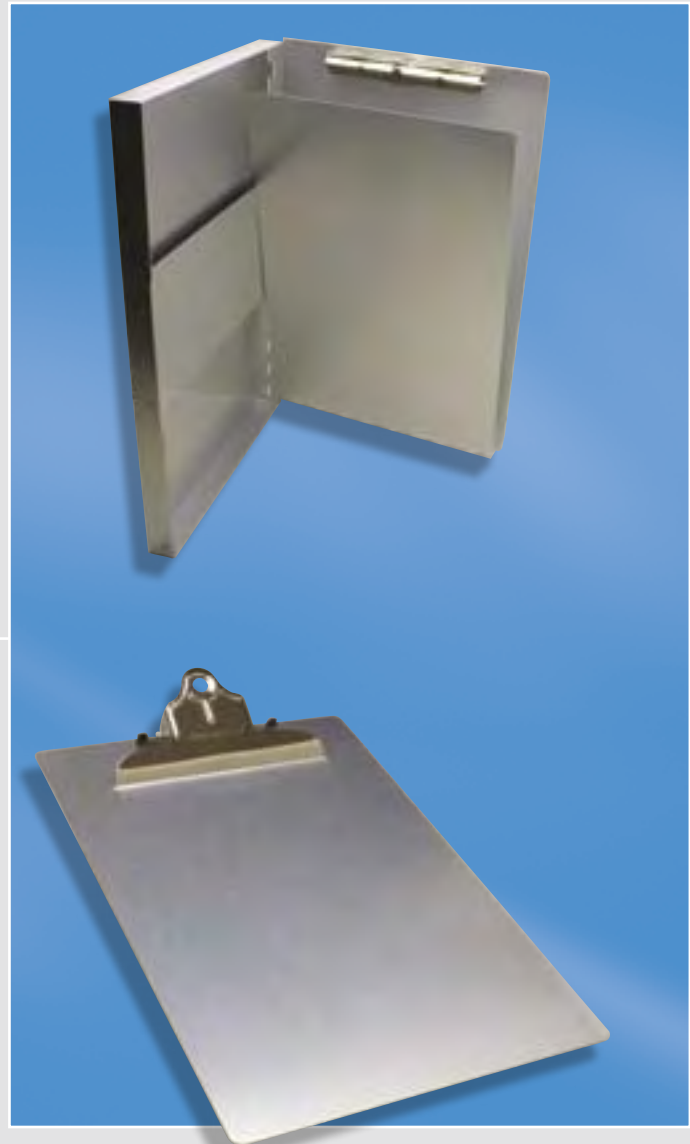

Redi Mate LED

A clipboard with integrated form cassette for special requirements. The integrated LED lamp replaces an additional reading lamp. The green LED is completely non-dazzling and provides ideal lighting conditions in the working area.

The form compartment opens at the top. The lamp is simply pushed into the cassette when it is not needed. High capacity (2.5 cm of paper) and the stylish design with rounded edges make this clipboard a top model. Colour black.

Order no.	Dimensions mm	Weight g
255518	230 x 350	950

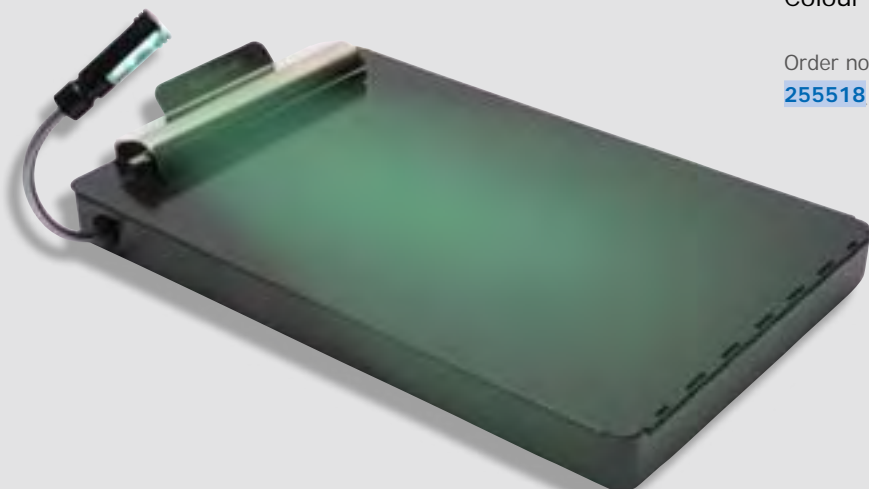



The increasing number of natural disasters and major accidents clearly show how important well-equipped units and emergency service personnel are in the disaster relief area. Dönges has been supplying federal and state authorities for many years. Reap the benefits of our experience!

Here you will find everything that you need for these operations.



Quick erection tents



Tent accessories



Food and drink/accommodation



**Vehicle loads
Disaster relief**

Inflatable tents	306-307	Accessories	
Pressure tents	308-312	Pressure tents	313-314
		Team tents	315

Compressed air cylinder	316	Electricity/gas tent heater	318
Compressed air filling kit	316	Diesel tent heater	319-321
Blower	317	Tent lighting	322

Eating crockery	323-324	Hygiene module	329
Kitchen crockery	325-326	Camp beds	330-331
Camping stove	327	Tables and seating	332
Food transport containers	328	Megaphone	332
Drinks container	328	Practice dummy	333

Medical equipment		Equipment trailer	337-339
vehicle	334-335	AB Decon V	339
Care equipment trailer	336		



ACD quick-erection tents

ACD has been manufacturing quick-erection tents for the armed forces, fire brigades and rescue services for almost 20 years.

The products range now includes a complete range of tents with different versions and sizes.



Air shelter II

Advantages:

- The Airshelter II is an ultra-light tent with a two-layer wall structure
- The blower creates an extremely sturdy tent with an inner area of almost 30 m² within just three minutes. The tent can also be lifted at the corners by four persons after inflating and is therefore extremely easy to position.
- The wall structure provides good insulation in summer and winter, without condensation on the inside
- Good natural lighting due to large white roof area. In order to avoid colour falsification during medical procedures, the red roof areas have been visually neutralised on the inside using green material
- The small packing dimensions make it easy to store the equipment.

Features:

- Large door opening for connecting to vehicles
- Single-handed door operation
- Extremely simple to connect two tents using optional tent Connector
- Both side parts can be fully removed
- Leadthroughs for heating/power at both sides

Inflatable tents

Inflatable tents are always used in conjunction with an electric or petrol-operated blower.

The outer skin of the tent consists of several air chambers that are filled using the blower. The air chambers are not airtight, meaning that the chambers have to be continuously supplied with air by the blower whilst the tent is being used.

The air-filled outer skin provides excellent heat and cold insulation and is practically insensitive to mechanical damage.

Inflatable tents are practically maintenance free and can also be used immediately, even after extremely long storage periods. Therefore perfectly suited to disaster relief applications.

Inflatable tents do not have a solid base and are therefore also ideal for use for mobile weather protection and concealment. The tent can be simply "folded" over the deployment location after inflation.



Technical data:

Dimensions: 450 x 750 x 360 cm
 Packing size: 120 x 65 x 75 cm
 Inner area: 29 m²
 Weight: 65 kg
 Material: Airtex 1000
 Colours: red/white

Scope of delivery:

Tent, packing bag, guy ropes, pegs, hammer, operating instructions and Blower E blower.

Order no.	Colour	Weight kg
220750	white	65
220700	red/white	65

Other colours and sizes available on request



Ballast tank

Set consisting of two water bags with fastening materials.

Ideal for securing the tent to solid surfaces (asphalt, concrete).

The ballast tanks have a universal filling opening and can be filled with practically any normal commercial water hose.

The tanks weigh approximately 600 kg when full.

Order no.

220705

Weight kg

2

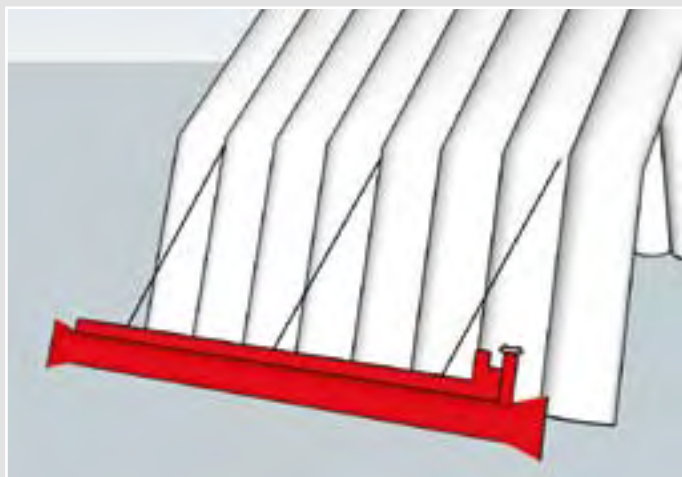

Blower E blower

Robust blower with metal housing for inflating and operating inflatable tents. Also suitable for use over several days.

Technical data:

Connecting voltage: 230 V

Connecting cable: 3 m long

Motor output: 1.1 kW

Protection class

Blower motor: IP55

Max. pressure: 0.26 bar

Air output: 1500 l/min

Dimensions: 34 x 21.5 x 40 cm

Weight: 17.5 kg

Order no.

220710

Weight kg

17,5



Connecting tarpaulin

Several Airshelter II products can be connected to each other and keep out the wind and the weather using this component. The connector is pulled into the respective zip fastener instead of the side parts.

Order no.

220715

Weight kg

1,8



Pressure tents

Pressure tents consist of a tent skin and a support frame made from inflatable compartments. The outer skin and the frame are connected to each other. When the frame is inflated, the skin unfolds and the tent is ready for use immediately. The entire frame is airtight, meaning that only the chambers need to be inflated to erect the tent. The tent can then be used for several days without having to do anything else. Either compressed air from air cylinders or an electric blower can be used to inflate the tent. The filling connections of the tents do not need to be adapted. The air frame is usually also maintenance free, but the tent should be erected at regular intervals to prevent material fatigue.

Properties of all tents:

- Two opposing entrances
- Inlets for warm air hoses and electric cables at both longitudinal sides
- Guy ropes at the sides
- Two combination inflation valves
- Two overpressure valves
- Several light securing facilities

Material specification:

Airtex 100:

Polyester rip-stop fabric with flame retardant effect

Airtex 200:

Specially coated natural rubber

Scope of delivery of all tents:

- Tent
- Packing bag
- Securing kit containing guy ropes, pegs and Hammer
- Fixed base

Windows and removable groundsheets can be ordered. Information about this can be found on page 320.

Depending on your preferred characteristics, we can supply two different layouts;

Rectangular layout:

Optimum usage of inner area, tents can be connected to each other at the rear

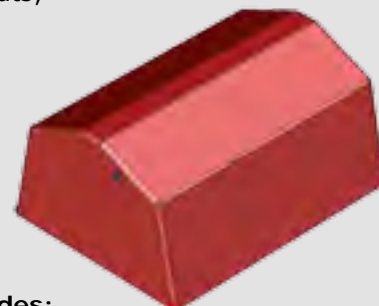

Rectangular layout with tapering at the sides:

Tents can be connected behind each other and at a 90° angle, better resistance to side winds, roof has better load-bearing capacity



Airshelter V

Dimensions: 370 x 325 x 230 cm
 Packing size: 100 x 50 x 35 cm
 Area: 10 m²
 Weight: 47 kg
 Filling volume: 1,400 l
 Frame material: Airtex 200
 Tent skin material: Airtex 100

Order no.	Colour	Weight kg
270620	red	47
270621	grey	47

Accessories:

Order no.	Item	Weight kg
270625	Ballast tank (2 pcs.)	6
270626	Connecting tarpaulin	2
270627	Partition wall, lateral	15
270628	Partition wall, longitudinal	20

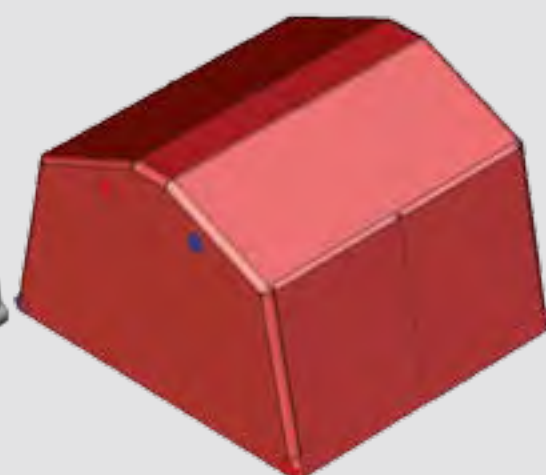
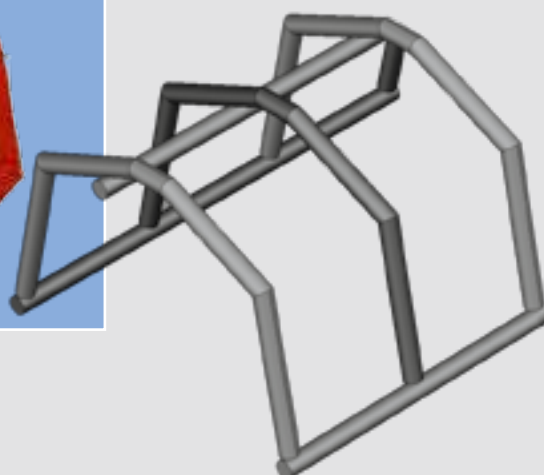

Air shelter IX

Technical data:

Dimensions: 500 x 400 x 265 cm
 Packing size: 120 x 75 x 55 cm
 Area: 20 m²
 Weight: 50 kg
 Filling volume: 3,000 l
 Frame material: Airtex 200
 Tent skin material: Airtex 100

Order no.	Colour	Weight kg
270660	red	50
270661	grey	50

Accessories:

Order no.	Item	Weight kg
270665	Ballast tank (2 pcs.)	6
270666	Connecting tarpaulin	2
270667	Partition wall, lateral	15
270668	Partition wall, longitudinal	30

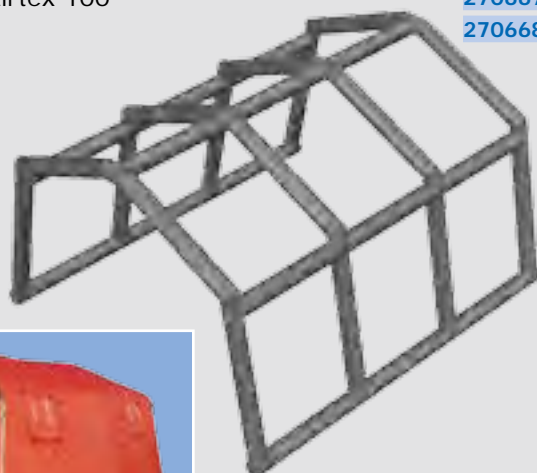

Airshelter XIII

Technical data:

Dimensions: 500 x 500 x 265 cm
 Packing size: 120 x 80 x 55 cm
 Area: 25 m²
 Weight: 65 kg
 Filling volume: 3,000 l
 Frame material: Airtex 200
 Tent skin material: Airtex 100

Order no.	Colour	Weight kg
270690	red	75
270691	grey	75

Accessories:

Order no.	Item	Weight kg
270695	Ballast tank (2 pcs.)	6
270696	Connecting tarpaulin	2
270697	Partition wall, lateral	15
270698	Partition wall, longitudinal	30

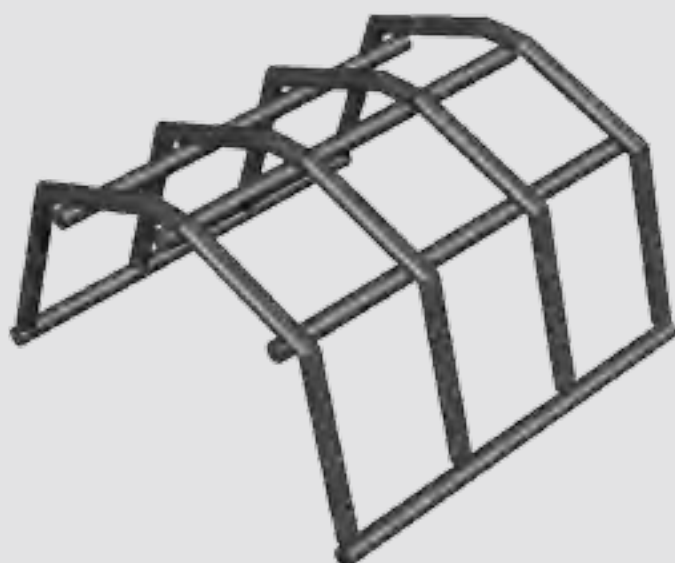

Info about accessories 
 on pages 313-314

Airshelter III

Dimensions: 600 x 450 x 280 cm
 Packing size: 120 x 80 x 45 cm
 Area: 27 m²
 Weight: 80 kg
 Filling volume: 3,400 l
 Frame material: Airtex 200
 Tent skin material: Airtex 100

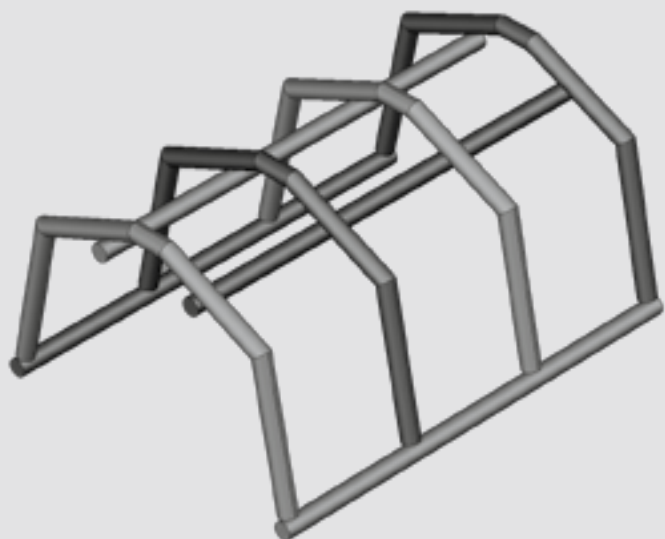

Order no.	Colour	Weight kg
270600	red	80
270601	grey	80

Accessories:

Order no.	Item	Weight kg
270605	Ballast tank (2 pcs.)	6
270606	Connecting tarpaulin	2
270607	Partition wall, lateral	15
270608	Partition wall, longitudinal	20

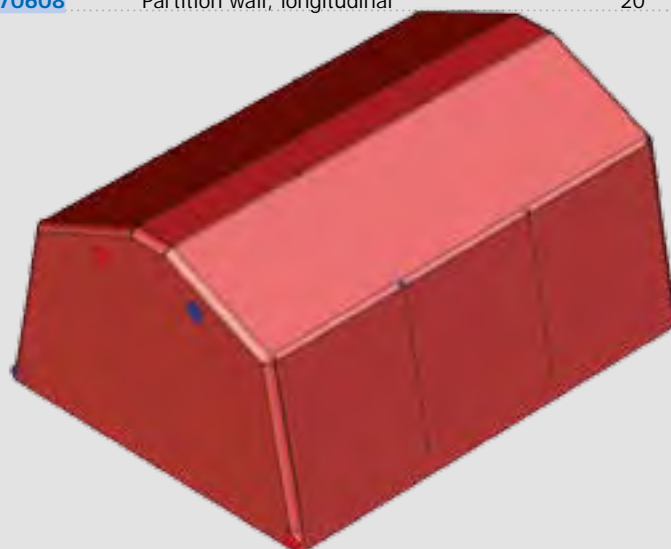

Airshelter VII

Dimensions: 600 x 570 x 290 cm
 Packing size: 120 x 70 x 65 cm
 Area: 34 m²
 Weight: 88 kg
 Filling volume: 5,000 l
 Frame material: Airtex 200
 Tent skin material: Airtex 100

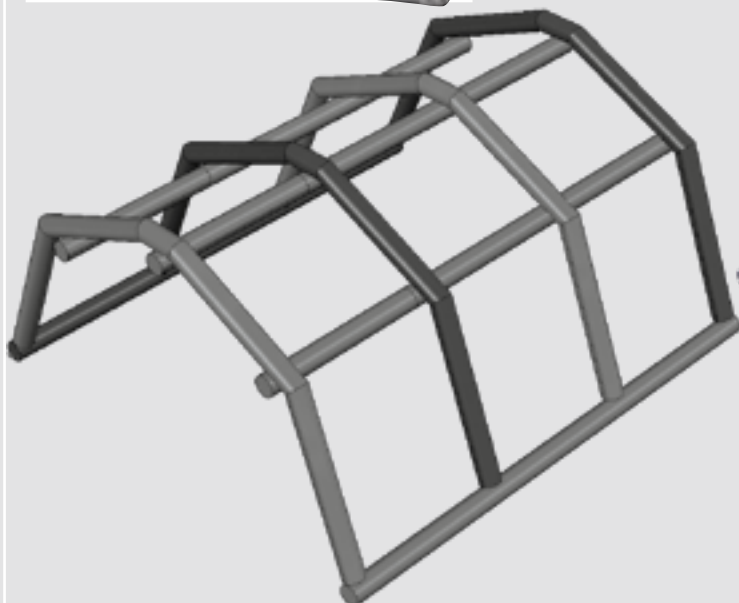

Order no.	Colour	Weight kg
270630	red	88
270631	grey	88

Accessories:

Order no.	Item	Weight kg
270635	Ballast tank (2 pcs.)	6
270636	Connecting tarpaulin	2
270637	Partition wall, lateral	15
270638	Partition wall, longitudinal	20

Info about accessories on pages 313-314



Airshelter XI

Technical data:

Dimensions: 600 x 570 x 290 cm
 Packing size: 120 x 75 x 65 cm
 Area: 30 m²
 Weight: 85 kg
 Filling volume: 5,400 l
 Frame material: Airtex 200
 Tent skin material: Airtex 100

Order no.	Colour	Weight kg
270670	red	85
270671	grey	85

Accessories:

Order no.	Item	Weight kg
270675	Ballast tank (2 pcs.)	6
270676	Connecting tarpaulin	2
270677	Partition wall, lateral	15
270678	Partition wall, longitudinal	20

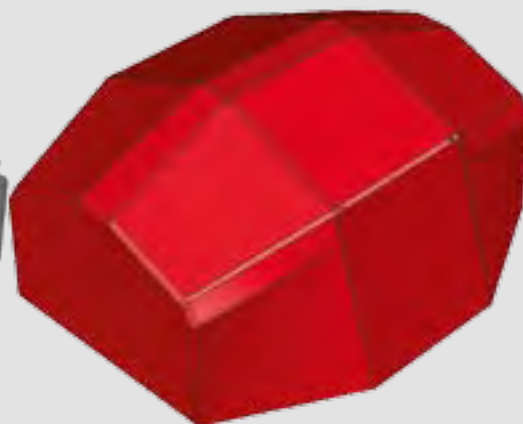
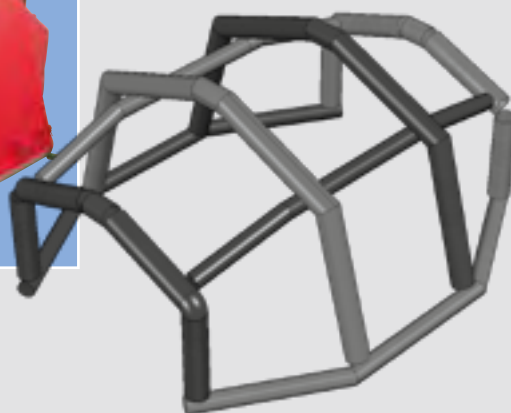

Airshelter IV

Technical data:

Dimensions: 840 x 570 x 295 cm
 Packing size: 120 x 80 x 65 cm
 Area: 47 m²
 Weight: 92 kg
 Filling volume: 7,000 l
 Frame material: Airtex 200
 Tent skin material: Airtex 100

Order no.	Colour	Weight kg
270610	red	95
270611	grey	95

Accessories:

Order no.	Item	Weight kg
270615	Ballast tank (2 pcs.)	6
270616	Connecting tarpaulin	2
270617	Partition wall, lateral	15
270618	Partition wall, longitudinal	30

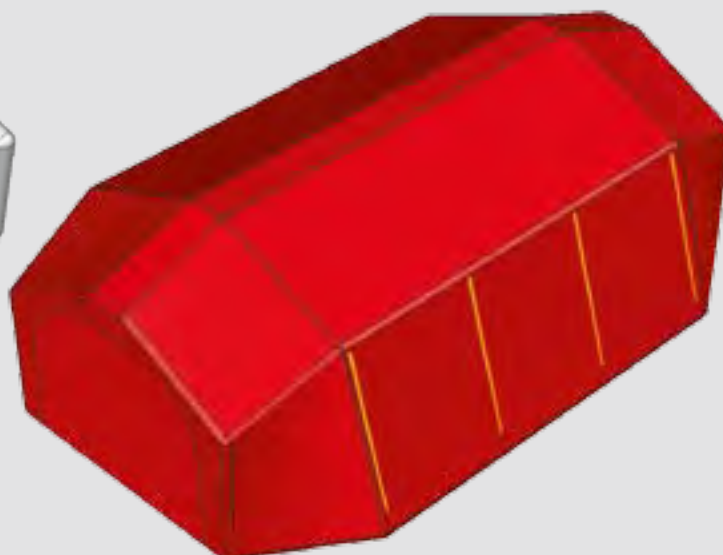
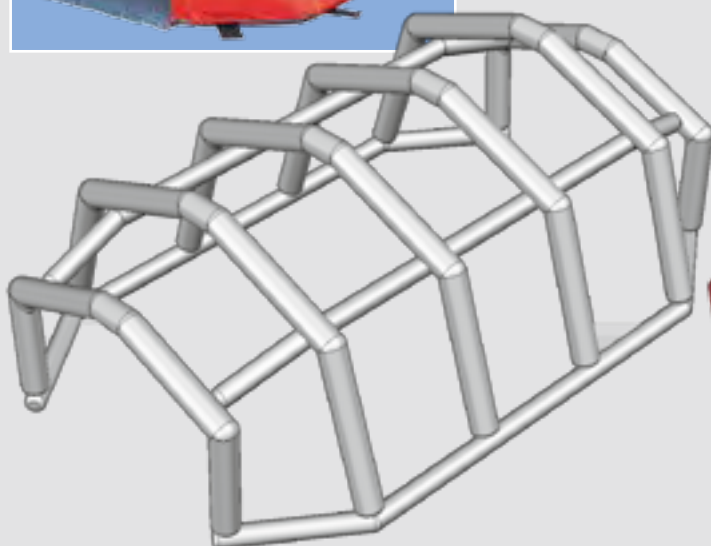

Info about accessories
 on pages 313-314



Airshelter VIII-S

Technical data:

Dimensions: 820 x 650 x 300 cm
 Packing size: 110 x 80 x 80 cm
 Area: 50 m²
 Weight: 110 kg
 Filling volume: 7,000 l
 Frame material: Airtex 200
 Tent skin material: Airtex 100

Order no.	Colour	Weight kg
270650	red	110
270651	grey	110

Accessories:

Order no.	Item	Weight kg
270655	Ballast tank (2 pcs.)	6
270656	Connecting tarpaulin	2
270657	Partition wall, lateral	15
270658	Partition wall, longitudinal	35

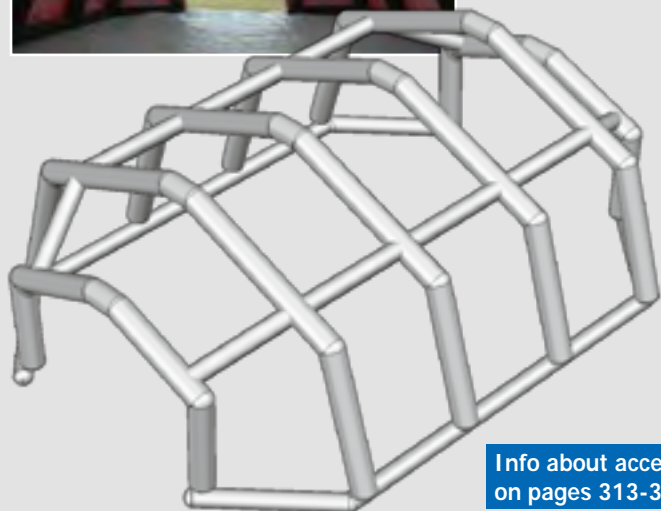

Info about accessories on pages 313-314



Airshelter VIII

Technical data:

Dimensions: 1030 x 650 x 300 cm
 Packing size: 130 x 80 x 80 cm
 Area: 61 m²
 Weight: 130 kg
 Filling volume: 8,500 l
 Frame material: Airtex 200
 Tent skin material: Airtex 100

Order no.	Colour	Weight kg
270640	red	135
270641	grey	135

Accessories:

Order no.	Item	Weight kg
270645	Ballast tank (2 pcs.)	6
270646	Connecting tarpaulin	2
270647	Partition wall, lateral	15
270648	Partition wall, longitudinal	30

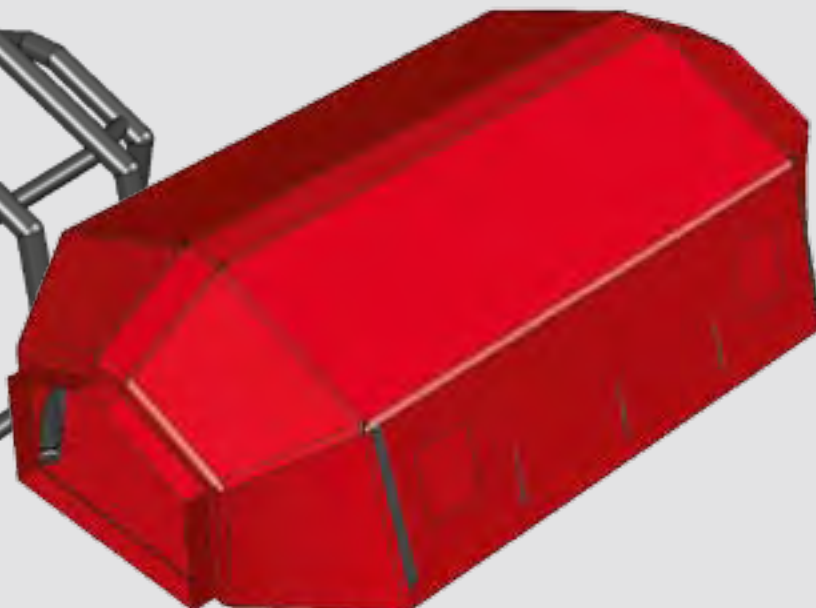
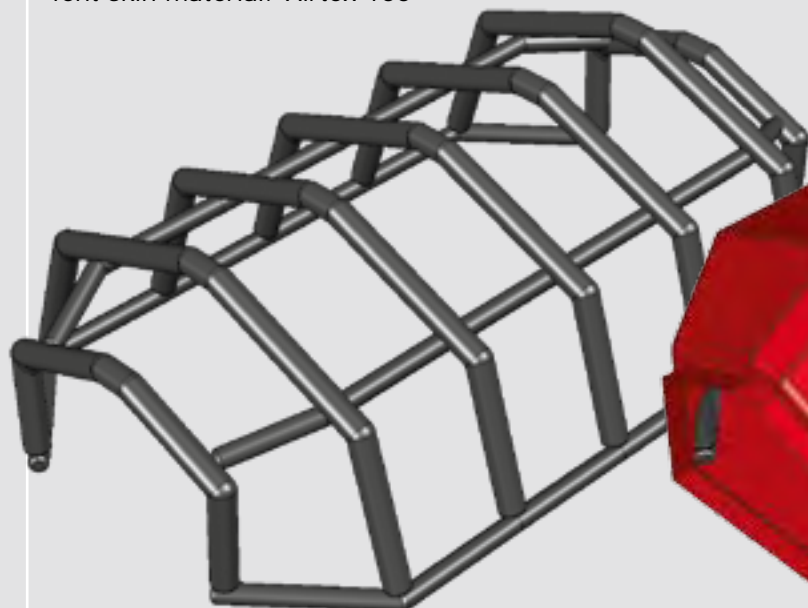

Ballast tanks

For securing the tent to a solid surface. The ballast tanks are directly attached to the guy ropes. They can be filled and emptied using any hose connection.

The kit consists of two ballast tanks.

Connecting tarpaulin

Provides a weatherproof connection between two tents. The tarpaulin is zipped into the surrounding zip fastener in place of the respective door element. Only two identical tent models can be connected to each other using the connecting piece.



Partition

The tent can also be partitioned internally using the partition wall. The partition walls are simply directly attached to the air frame. The partition wall can either be longitudinal or lateral.

Special versions available on request!



On this page you will find pictures of the tent accessories, which vary depending on the tent. The order numbers can be found next to the relevant item!





1

Window element

Up to six window elements can be installed depending on the size of the tent.
This feature cannot be retrofitted!

One window always consists of three layers:

- 1 Fixed, sewn-in gauze net as insect protection
- 2 Roll-up transparent cover for windproofing and weatherproofing
- 3 Roll-up canvas cover as visual cover

The roll-up covers are tied up using Hook & Loop tape.



2

Order no.

270711

Weight kg

2



3

The items shown here can only be ordered together with the required tent !



Removable floor

The fixed groundsheets that are installed in the factory are also equipped with Hook & Loop strips. The floor can therefore be removed if necessary.
This feature cannot be retrofitted!

Order no.

270710

Weight kg

5



Accommodation and team tents

Specially developed for fire brigades, aid organisations and disaster relief organisations. This tent is specially characterised by top quality workmanship and the following features:

Features:

- Aluminium frame with diecast aluminium connectors
- Reinforced tubes with 40 mm diameter and 2 mm wall thickness
- Surface with top quality sealing and calibration
- Base rods made from hot-galvanised steel
- Tarpaulin made from heavy duty fabric 50% cotton/ 50% polyester, with water-resistant impregnation, fungicide, approx. 420 g/m²
- Extremely tear-resistant and breathable
- Bottom strips made from coated PVC polyester fabric
- Entrance with toggle fastener, insect screen and material flap cover.
- Storm bracing receptacles at the tent gables

Scope of delivery:

Full set of accessories with tent packing cloth, frame, saddlebag and bracing materials.

Dimensions:

Tent width: 595 cm
 Side height: 195 cm
 Roof height: 305 cm
 Tent depth: Model-dependent



Tent is available in three different lengths:

GZ 600

Tent depth: 600 cm
 Windows: Two
 Weight: Tent skin 56 kg
 Frame 51 kg

GZ 800

Tent depth: 800 cm
 Windows: Four, two rollup sides
 Weight: Tent skin 70 kg
 Frame 64 kg

GZ 1000

Tent depth: 1,000 cm
 Windows: four, two rollup sides
 Weight: Tent skin 82 kg
 Frame 77 kg

Order no.	Item	Weight kg
257510	GZ 600	107
257520	GZ 800	134
257530	GZ 1000	159



Partition

For lateral partitioning of different areas in the tent. Suitable for all Dönges frame tents.

Gable connector

For covering the gap between two tents erected together at the gable side. Suitable for all Dönges frame tents.

Order no.	Item	Weight kg
257515	Partition	7
257516	Gable connector	6

Groundsheet

Groundsheet made from heavy-duty polyester fabric coated with PVC on both sides

Order no.	suitable for	Weight kg
257511	GZ 600	18
257521	GZ 800	23
257531	GZ 1000	29

Compressed air cylinder

Compressed air cylinder for inflating pneumatic tents, operating pneumatic pumps, plasma cutting equipment etc. Operating pressure 300 bar, 6 litre capacity. Steel cylinder with valve connection M18 x 1.5. With rotary valve and sealing plug. Supplied with CE marking, conformity declaration in compliance with 97/23/EC (pressurised equipment directive) and testing before start-up in accordance with §14 BetrSichV, fully filled.

Features:

- Gas type: breathing air
- Material: CrMo steel
- Max. permissible operating pressure: 300 bar
- Capacity: 6 l/content 1800 l
- Test pressure: 450 bar
- Deployment temperature range: -30°C to +60°C
- Test interval: 10 years

Order no.	Dimensions mm	Weight kg
220550	140 Ø x 615	10,7



Compressed air inflation kit

Needed if a decontamination cabin or pressure tent is being erected using compressed air cylinders.

1 Set 1

Has one connection for the pressure reducer and two outlets as inflation connections. Needed for inflating tents.

Set 2

Has one connection for the pressure reducer and one outlet as an inflation connection. Needed for inflating decontamination cabins or basins.

Scope of delivery:

- 1 x Pressure reducer 300 bar
- 1 x Connecting nipple outlet for quick-release compressed air connection
- 1 x Compressed air hose with quick-release couplings at both ends

Order no.	Version	Weight g
270713	Set 1	1500
270714	Set 2	1500





Blower F

Blower for erecting pressure tents. Can also be used for deflating the tent when it is taken down.

Technical data:

Connecting voltage:	230 V
Connecting cable:	5 m long with IP68 connector
Motor output:	0.96 kW
Max. pressure:	0.26 bar
Air output:	1500 l/min
Dimensions:	30 x 25 x 22 cm

Order no.	Weight kg
270701	8

Air hose

For connecting the blower to the inflating valve of the tent or decontamination cabin. Fits to all inflating valves on ACD pressure tents.

Two hoses are needed to inflate two-chamber tents. Only one inflating hose is needed to inflate single-chamber tents or decontamination cabins. The second outlet opening of the blower must then be sealed with a dummy plug. The hoses are made from thermosetting material that is kink-proof and non-slip.

Hose length 5 m



Order no.	Item	Weight kg
270702	Hose	0,5
270703	Dummy plug	0,1

Blower F set

Scope of delivery:

- 1 x Blower F
- 2 x Connecting hose 5 m
- 1 x Dummy plug
- 1 x Transportation box
(optionally plastic or Zarges Euro box)

Dimensions:

Box 60 x 40 x 25 cm

Order no.	Item	Weight kg
270700	Set with plastic box	9,5
270707	Set with Zarges Euro box	10,5





Tent heaters

Mobile heaters for heating tents, buildings and emergency accommodation.
The right heat source for all purposes, operated using electricity, gas or oil.

Electric heating fan

Quick and reliable heating wherever a power connection is available. The electric heater can be installed directly at the deployment site and provides a pleasant climate.

Features:

- Double-walled sheet metal housing
- Stainless steel heating element
- Overheating protection
- Practical carrying handle

Technical data:

Heating output: 3 kW
Blower output: 250 m³/h
Electrical connection: 230 V/13 A

Order no.	Dimensions mm	Weight kg
257020	280 x 330 x 370	6

Gas-operated heating blower

Clean heating with gas. A 230 V connection and a propane gas cylinder are needed to operate the equipment, Can be used anywhere where the deployment area can be adequately ventilated.

Features:

- High performance at a reasonable price
- Rust-free outer jacket
- Maintenance-friendly
- Double protection for the gas supply
- Electronic ignition
- Flame monitoring with thermal element
- Overheating protection

Technical data:

Heating output: 16 - 30 kW controllable
Blower output: 1,000 m³/h
Gas consumption: 1.25 - 2.2 kg/h

Scope of delivery:

- 1 x Gas-fired heating blower
- 1 x Adjustable gas pressure regulator
- 2 m connecting hose with hose rupture protection
- 1 x thermostat with 5 m cable

Attention:

not suitable for heating confined spaces!



Order no.	Dimensions mm	Weight kg
257030	595 x 260 x 365	10

Oil heating fan

Comfortable heating - also for longer periods. The unit is operated outdoors and leads the warm air into the room that is being heated via a hose. The oil heating blower can therefore be deployed in an extremely flexible way. Economical consumption and a large fuel tank ensure that heating can also be provided for long periods. The automatic heaters can be operated using diesel or heating oil. A fuel tank heater that is available as standard ensures that the equipment also operates correctly at minus temperatures.

The heating output is conveniently regulated via the standard room thermostat.

Extremely easy to use, just fill with fuel and connect the power and the heater is ready for operation.

Features:

- 100% clean heat
- 91% efficiency
- Phosphatised sheet metal housing, powder coated
- Stainless steel combustion chamber
- Powerful blower
- 40 litre tank is adequate for more than 16 hours of continuous operation (ITA30)
- Pressurised waterproof connector available on request (IP68)
- Integrated fuel tank heater



Technical data:

	ITA 30	ITA 45
Heating output:	24.8 kW	48.4 kW
Blower output:	1,100 m ³ /h	2,700 m ³ /h
Fuel consumption:	2.0 kg/h	3.8 kg/h
Fuel tank capacity:	40 l	80 l
Air outlet cone:	300 mm	400 mm
Warm air hose:	WLS 30	WLS 40
	(please order separately)	

Scope of delivery:

- 1 x Oil-fired heating blower
- 1 x Galvanised flue with rain cowl
- 1 x Room thermostat with 10 m connecting cable

1



2

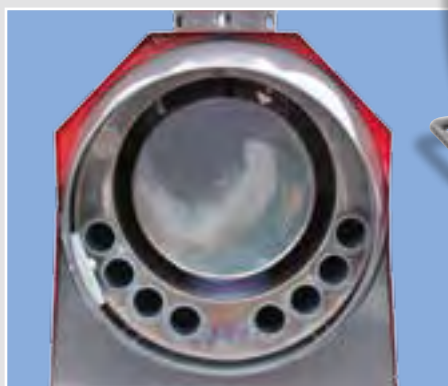

Stainless steel combustion chamber

	Order no.	Model	Weight kg
1	257010	ITA30	58
2	257011	ITA45	134

ACD Heater 30L tent heater

The ACD Heater 30L has been specially designed for mobile deployment as a tent heater, and has many advantages compared to other tent heaters:

Features:

- No integrated fuel tank
- Lightweight
- Additional ventilation function for use in summer
- 10 m connecting cable with IP68 shockproof plug
- Undercarriage with skids, can therefore be stacked without problems
- Four carrying handles
- Circulated air possible using additional air hose

Because of the fact that there is no integrated fuel tank, the heater is smaller and easier to transport because it is lighter. Nor does the tank need to be drained before loading the equipment into a vehicle. The heater is operated directly from a 20 l sheet metal canister. (According to ADR, diesel and heating oil must only be transported on public roads in permissible containers. The tank of a tent heater is not approved for this type of transport)

Technical data:

Housing material: sheet metal, powder coated
 Heating output: approx. 25 kW
 Air output: 1,100 m³/h
 Fuel: diesel or heating oil
 Air outlet cone: 300 mm
 Connecting cable: 10 m with IP68 shockproof plug
 Warm air hose: WLS 30 (please order separately)

Scope of delivery:

heating blower, room thermostat, exhaust pipe with rain cowl and operating instructions

Order no.	Dimensions cm	Weight kg
257017	120 x 46 x 50	35



Warm air hoses

For transporting the heated air from the heater to the deployment site. Can be used in conjunction with the ITA30, ITA45 oil-fired heating blowers and the ACD 30L Heater. A strap is also required to secure the hose to the heater.

Features:

- PVC-free material
- Unplasticized (no troublesome vapours)
- Flexible in cold weather
- Reinforced with spiral spring
- Can be compressed in ratio of 1:10
- Non-sensitive to soiling
- Standard colour yellow/black
- Connected with spiral-free sleeve and tension strap

Order no.	Model	Ø mm	Length m	Weight g
257040	WLS 20	200	7,6	5000
257041	WLS 30	300	7,6	6000
257042	WLS 40	400	7,6	7000
257036	Securing strap			50

Warm air hose

Also with sewn-on carry bag.

Order no.	Model	Ø mm	Length m	Weight g
257043	WLS 20T	200	7,6	5800
257044	WLS 30T	300	7,6	6800
257045	WLS 40T	400	7,6	7800



Air distributor

For heating two tents simultaneously with just one ITA30.

The distributor is directly attached to the heating unit and secured with the provided tension clamp.

Two WLS warm air hoses are needed for ducting the warm air. This ensures that the warm air distribution in both tents is adequate.

Order no.	Weight g
257047	4000

Mobile heater "Polarn"

Polarn brings heat to any location. This compact heating system, which is operated using diesel fuel, is easy to transport and ready for use in a flash. An ideal solution for fire brigades, rescue services and other users who need to keep out the cold in a flexible and uncomplicated way - to protect persons, technical equipment and products.

Typical deployment areas for "Polarn"

- Supplying heat for accident victims and injured persons
- Use during rescue work/operations
- Heating tents during operations by aid organisations, the fire brigade and the armed forces
- Heating containers and mobile supply stations
- Extremely compact dimensions
- Quick, uncomplicated start-up
- Operating voltage 12 V, optionally 230 V
- Circulated air operation possible for increasing heating performance

Two versions of the equipment are available:

Technical data:

	Polarn 4000	Polarn 8000
Heating levels:	4	2
Max. Hot air throughput:	185 l/min	310 l/min
Consumption: max. power	max. 0,51 l/h	max. 1.05 l/h
Consumption:	40 W (operation)	115 W (operation)
Weight:	11 kg	26 kg
Undervoltage protection:	Yes	Yes
Equipment:	Built-in fuel tank Exhaust pipe Warm air hose Connecting cable	Suction nozzle for fuel canister Exhaust pipe Warm air Hose Connecting cable

Order no.	Version	Weight kg
1 257015	Polarn 4000	11
2 257016	Polarn 8000	26



Tent and working light

Light for the most demanding requirements that is used all over the world. Sturdy housing made from aluminium with plastic ends. Two fluorescent tubes for bright, neutral light. Several lights can be connected in series using a pressurised waterproof socket. The tent lights are available in two standard versions, with 2 x 36 and 2 x 55 Watt tubes.

The tent lights were specially designed to have a long service life. The robust metal body, the curved lens and the shock-absorbing end pieces ensure that the light works reliably, even under extreme conditions. The light remains operational even after hard impacts. Power consumption is extremely low, which is a decisive advantage when operating with generators. The light output is extremely high compared to conventional halogen floodlights.

Features:

- Aluminium/plastic housing
- Bulb: 2 x 36 W/2 x 55 W Brand name tubes
- Corresponds to halogen floodlight output of 500 W/1000 W
- Integrated Schuko® socket IP68
- 5 m rubber connecting cable with Schuko® connector IP68

Order no.	Dimensions mm	Output	Weight kg
220882	480 x 126 x 180	2 x 36 W	3,0
220884	600 x 126 x 180	2 x 55 W	3,5



DOENGES
exclusive

Tent lighting operations box

During disaster relief operations or major incidents, tents are often used to provide injured persons with first aid or look after victims or the rescue services. Of course, tent lighting is an indispensable part of this equipment.

This Zarges Euro box contains two 2 x 36 Watt tent lights and a delta box for connecting these tent lights to the power supply. Everything that is needed for the tent lighting is therefore accommodated in a compact and safe way, and is easy for the rescue services to carry.

Features:

- Well-ried, sturdy Zarges Euro box for safe storage and easy transportation
- Tent lights provide bright and neutral light
- Delta box for safe connection of the tent lights and possibly other consumers to the power supply

Order no.	Item	Dimensions mm	Weight kg
258070	"Lighting" Euro box	600 x 400 x 340	12,3



Reusable crockery

Ideal for disaster relief services, care services and events

- High-quality crockery made from melamine
- Completely odourless and tasteless
- Dishwasher compatible
- Food-safe
- Complies with food regulations
- Regularly monitored
- Classical design
- Reusable
- Standard colour white

Properties of melamine:

- Practically unbreakable
- Extremely strong
- Permanently heat resistant up to 100° C (120 - 180° C for short periods)
- Cold resistant up to -40° C (deep-freeze resistant)



Eating crockery

Order no.	Model	Ø mm	Material	Weight g
1	258010 Plate, flat	195	Melamine	122
2	258011 Plate, flat	235	Melamine	188
3	258012 Plate, deep	205	Melamine	198

Order no.	Model	Capacity ml	Material	Weight g
4	258023 Soup bowl	500	Melamine	105
5	258025 Soup bowl	1000	Melamine	224



1



2



3



4



5



made
in
Germany



Serving spoons

Features:

- Melamine cooking spoon
- SAN serving spoon

Order no.	Model	Length mm	Material	Weight g
258019	Cooking spoon	380	Melamine	88
258020	Cooking spoon	450	Melamine	128
258021	Cooking spoon	600	Melamine	236
258022	Serving spoon	335	SAN	61

Stainless steel cutlery

Complete cutlery set consisting of knives, forks, table-spoons and teaspoons, dishwasher safe

Order no.	Weight g
258040	80



Plastic cutlery

Cutlery consisting of knives, forks, tablespoons and teaspoons. Can be used several times.

Features:

- Material SAN
- Colour silver
- Dishwasher safe

Order no.	Weight g
258045	34



Kitchen crockery
 For hygienic working in the kitchen and clean serving areas.
 All items approved for commercial use.



made in Germany

Serving dish

Can be used for cooking or making and serving side dishes. Made from melamine, almost unbreakable and dishwasher safe

Order no.	Capacity ml	Dimensions mm	Weight g
258014	1000	156 x 156 x 65	195
258013	2000	200 x 200 x 75	265
258015	3000	220 x 220 x 90	430

Serving dish

Stylish dish for serving food.
 Can be combined with side dishes.

Features:

- Dish made from melamine
- Lid made from SAN
- Capacity 3,000 ml
- Hard-wearing
- Dishwasher safe



made in Germany

Order no.	Model	Ø mm	Weight g
258046	Dish	240	532
258047	Lid	240	140

Side dish

The special shape of the side dish makes it possible to have countless design variants for your serving table or buffet. Also ideal for combining with the serving bowl.

Features:

- Made from melamine
- Capacity 1300 ml
- Hard-wearing
- Also available in black, red, yellow, green and blue

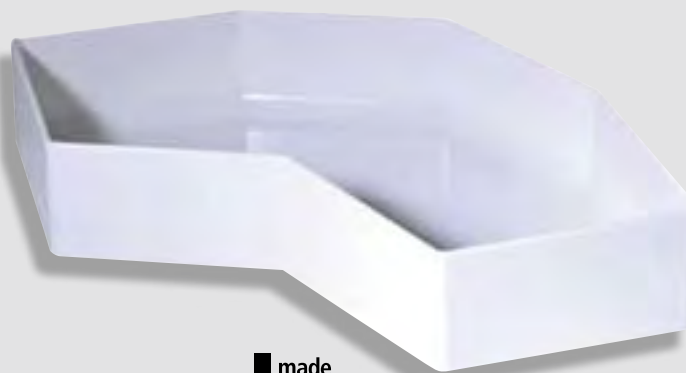

made in Germany

Order no.	Dimensions mm	Colour	Weight g
258049	300 x 135	white	360



The serving bowls and side dishes can be combined in any colour and shape.



made in Germany

Display tray

Ideal for preparing ingredients and storing prepared dishes for short periods.

Features:

- Bowl made from PP
- Lid made from SAN
- Heat resistant up to 75°C
- Cold resistant up to -40°C

Order no.	Model	Dimensions mm	Weight g
258016	Bowl	280 x 210 x 70	258
258017	Lid	284 x 214	190

Food storage box

Box with transparent lid.

Features:

- Dish and cover made from SAN
- Temperature resistant from -20 to +70° C
- Resistant to freezing
- Dishwasher safe



made in Germany

Order no.	Model	Dimensions mm	Weight g
258018	Bowl with lid	356 x 247 x 85	790

Beaker



1



2



3

Order no.	Model	Capacity ml	Material	Weight g
1 258024	Drinking cup	250	Melamine	76
2 258036	Coffee cup	380	Melamine	162
3 258037	Drinking cup	300	PP/Transparent	41

made in Germany





Ladle

Made from one piece, without joints.

Features:

- Heavy-duty version
- Stainless steel
- Dishwasher safe

Order no.	Capacity l	Length mm	Weight g
258075	0,5	400	180
258076	0,75	440	240

Cooking pot

Sturdy cooking pot made from stainless steel, medium-heavy quality, for electric and gas cookers. Capacity 20 litres.

Order no.	Ø mm	Height mm	Weight g
258039	320	260	4100



Camping stove

Extremely robust, powerful camping stove made from cast iron High-performance stove with safety pilot, output 9.2 W, single flame Approved for commercial use.

Scope of delivery:

Gas pressure regulator, connecting hose and hose rupture protection, gas cooker

Order no.	Dimensions mm	Weight g
258041	380 x 560 x 380	9000



Food transport containers

Aid organisations are also responsible for providing victims with food and drink in the event of disasters. This includes providing hot food. These robust containers are the ideal solution. Hot dishes remain hot for at least 6 hours in a full 25 l container!

Features:

- Extra sturdy quality
- Easy to clean
- Does not affect taste
- Outer casing and lid made from lacquered sheet steel or stainless steel 18/10



made in Germany

- All containers (including lid) stainless steel 18/10 on the inside
- Strong base ring
- Sturdy fall handles
- Lid with rubber seal, from 10 l with pressure equalisation valve
- Inserts stainless steel 18/10

Lacquered/stainless:

Order no.	Version outside/inside	Capacity l	Weight kg
258100	Lacquered/Stainless	10	9,0
258101	Lacquered/Stainless	15	10,7
258102	Lacquered/Stainless	20	13,6
258103	Lacquered/Stainless	25	15,0
258104	Lacquered/Stainless	30	16,9

Stainless/Stainless:

Order no.	Version outside/inside	Capacity l	Weight kg
258105	Stainless/Stainless	10	9,0
258106	Stainless/Stainless	15	10,7
258107	Stainless/Stainless	20	13,6
258108	Stainless/Stainless	25	15,0
258109	Stainless/Stainless	30	16,9

Inserts:

Order no.	Version	Capacity l	Weight kg
258110	Stainless steel	10	0,8
258111	Stainless steel	15	1,2
258112	Stainless steel	20	1,3
258113	Stainless steel	25	1,6
258114	Stainless steel	30	1,8

Insulated drinks container

Of course, providing victims with drinks also plays just as important a part. The double-wall insulated drinks containers are suitable for hot and cold drinks. The containers have a tightly sealed lid with rubber seal and valve. Three hinged catches ensure that the lid is securely shut. The tap does not drip and is protected from impacts etc. by a tap protection bracket. Also ideal for use in hospitals, homes, canteens, at parties etc.

Features:

- Extra sturdy quality
- Easy to clean
- Does not affect taste
- Double-wall insulation inside and outside
- Stainless steel 18/10
- Strong base ring
- Sturdy stirrup handle/side handles (25 l)
- Can be stacked without lid
- Lid with rubber seal and valve

Order no.	Dimensions mm	Capacity l	Weight kg
258115	300 x 280 Ø	10	9,0
258116	390 x 360 Ø	25	15,0



made in Germany

Hygiene module

Specially for use in duty locations, dressing stations or emergency service tents.
Two suspension eyes are cut into the 8 mm thick carrier plate so that the entire module can be handily suspended from two hooks.

Dimensions:
52 x 32.5 cm

Scope of delivery:

Hand washing lotion dispenser, hand disinfectant dispenser, paper towel dispenser, hand washing brush.

Normal commercial Euro bottles can be put into the dispensers.

Order no.	Item	Weight g
1 258210	Hygiene module, complete	2000
2 258220	Soap dispenser	500
3 258230	Disinfectant dispenser	500
4 258240	Paper towel dispenser	400
5 258250	Hand washing brush	20
258052	Transportation box 600 x 400 x 410 mm	4900



Water canister

Polyethylene drinking water canister, with tap. Capacity 20 litres.

Features:

- Food-safe
- With removable tap, easy to clean
- Robust and resistant to impacts
- End cap secured with strap to prevent loss

Order no.	Dimensions mm	Weight g
258038	416 x 203 x 408	940



Camp beds

Uncomplicated, well-trying design, robust and compact. For fire brigades, medical services and disaster relief organisations. Well-trying many times in operations all over the world.

Be it as a bed in emergency accommodation or a day bed in a common area, camp beds can be used almost anywhere where a comfortable resting or sleeping place is needed at low cost. We can supply camp beds that are suitable for your needs.



Camp bed, beech

made
in
Germany

Made from dry, knot-free beech, with galvanised steel fittings. With tensioning bars and straps made from coated fabric. Cover made from grey linen canvas.

Technical data:

Dimensions: 195 x 79 x 49 cm open
96 x 22 x 12 cm closed

Load capacity: 120 kg
Weight: 10 kg

Order no. **258120** Weight kg 10,0



Aluminium camp bed

made
in
Germany

For anyone who requires less weight but still wants the stability of the wooden classic. Aluminium frame, galvanised steel hardware. Cover made from tear-resistant polyamide fabric.

Technical data:

Dimensions: 195 x 79 x 44 cm open
96 x 20 x 13 cm closed

Load capacity: 120 kg
Weight: 7.5 kg

Order no. **258121** Weight kg 7,5



Luxury aluminium camp bed

Sturdy camp bed with comfortable dimensions. Sturdy workmanship for the most demanding requirements. Rod system made from square aluminium tubing, 32 x 32 mm, wall thickness 1.7 mm. Cover made from polyester 600 x 600 with tension adjusting facility. Supplied complete in pack sack.

Technical data

Dimensions: 210 x 87.5 x 52 cm open
105 x 25 x 15 cm closed

Load capacity: 120 kg
Weight: 11 kg

Order no. **258123** Weight kg 11,0

Camp bed, Economy

Lightweight camp bed for use as day bed or guest bed. Simple version. Anodized aluminium frame, with metal fittings. Cover made from durable nylon fabric. Supplied with pack sack.

Technical data:

Dimensions: 191 x 64 x 41 cm open,
95 x 20 x 12 cm closed
Load capacity: 90 kg
Weight: 5.5 kg



Order no.	Weight kg
258122	5,5...

Pack sack for camp beds

The pack sack is suitable for the majority of popular standard size camp beds

Technical data:

Dimensions: 100 x 35 cm
Material: Canvas



Order no.	Weight kg
258124	0,3...



PAX® Blanket bag

Transportation and storage bag for woollen blankets or patient blankets. Made from robust Pax®-Plan.

Order no.	Dimensions cm	Weight kg
253705	60 x 50 x 40	2,0...

Woollen blanket

Mixed fabric.

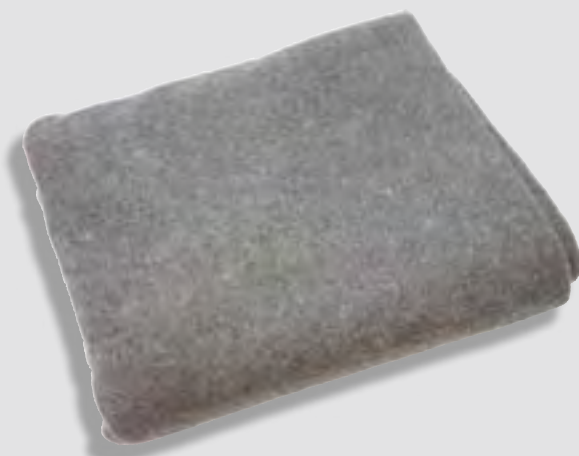

Order no.	Dimensions cm	Weight kg
218520	150 x 200	1,4...

Marquee set

Heavy-duty beer garden furniture in brewery quality, with folding frame made from painted metal. Water-proof. Table and bench tops made from solid for or pine, with UV-resistant varnish. Tables and bench tops each with three stacking battens. The base frames are made from angled steel, 30 mm. The spring locks keep the base frame securely in position when the furniture is collapsed.



Order no.	Item	Dimensions mm folded up	Weight kg
258043	Folding table	2200 x 500 x 720	12
258042	Folding bench	2200 x 300 x 450	8



Folding chair

Simple, low-cost folding chair made from solid beech, varnished. Also suitable for use outdoors for a limited period. The compact collapsed chair is extremely easy to store away.

Order no.	Item	Dimensions mm folded up	Weight kg
258044	Folding chair	440 x 770 x 60	3,2

Megaphone

Megaphone with 25 W amplifier output. Makes long distance communication possible. The megaphone can be optionally used with the built-in microphone or the external microphone.

Features:

- Range up to 300 m
- Built-in microphone
- External microphone with 1.5 m spiral cable
- Infinitely variable volume control
- Additional audio-in connection
- Power supply - six type D batteries (Mono)
- LED operating indicator
- Hand strap

Batteries not included in scope of delivery.

Order no.	Item	Weight kg
256499	Megaphone	1,4
241014	Battery D/Mono/LR20 (6 batteries required)	0,14



Suitable batteries on page 192-193



"Practice Paul" practice dummy

Sturdy practice dummy made from hard-wearing material for many different type of practice in fire brigades, rescue services, disaster relief organisations and THW. The dummy can be filled with many different materials. This means that different weights and therefore different practice situations can be simulated.

The dummy has a transparent pocket with Hook & Loop fastener in the chest area. Signs or casualty examples can be attached here. There is a zip fastener for opening the head of the dummy

that can be used to insert a hot water bottle, for example, for locating with a thermal imaging camera.

A radio can also be inserted.

This makes the situation even more realistic.

The dummies are available in three sizes. Adult 185 cm, child 110 cm, baby 70 cm.

Features:

- Sturdy material for the harshest conditions.
- Darts inside for better distribution of the filling materials
- Transparent pocket in chest area
- Zip fastener on head
- Self-filling, therefore allowing weight to be varied and making the dummy easier to store and transport

Order no.	Height cm	Weight kg
220960	70	0,1
220955	110	0,5
220950	185	1,5



NRW disaster relief equipment

This major project started in 1995: The aid organisations and the regional governments of the state of North Rhine Westphalia worked out a concept for "Defending against major disasters".

Equipment vehicles and trailers with different configurations were to be available for possible disasters such as terror attacks, train crashes or major road accidents, but were primarily also obtained for "normal" deployment by the aid organisations, such as providing supplies for firemen during operations or looking after people after house evacuations. Some of the most successful aid operations in recent years were the World Youth Day (with visit from the Pope) in Cologne, the snow chaos in Münsterland and the football World Cup.

Dönges has been supplying the equipment for these equipment vehicles and trailers to the state of North Rhine Westphalia since 2005. Other vehicle and load concepts have since been planned and delivered to districts and municipalities all over Germany.

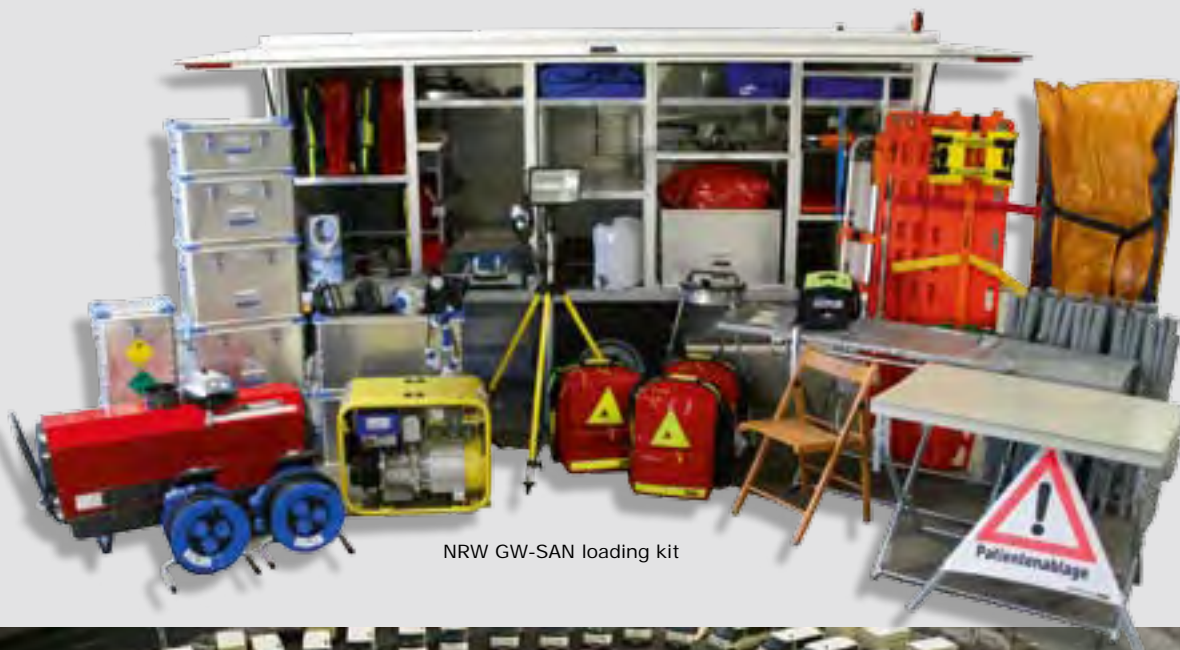
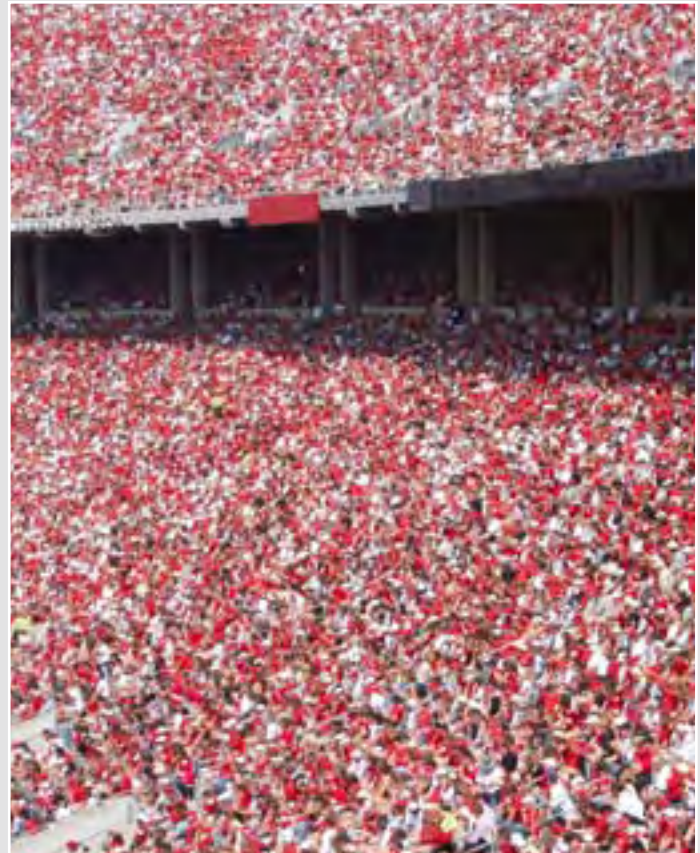

NRW GW-SAN loading kit



Vehicle handover in Düsseldorf

Loading kit Medical equipment vehicle

Order no.	Name	Weight kg
259560	Set, complete	1180

Loosely loaded:

Order no.	Quantity	Name
259009	10 x	Medical backpack PAX Wasser kuppe III, NRW K-Schutz
252520	10 x	Pulse oximeter BCI 3402
259100	1 x	Zoll AED Plus with ECG display
230100	10 x	Cervical support, adult
230110	10 x	Cervical support, child
253502	10 x	Stretcher DIN 13024-2
251030	10 x	Infusion tripod for stretcher
251040	3 x	Stretcher storage stand
254010	5 x	Spinal board
254020	2 x	Scoop stretcher EN 1865
254200	1 x	Vacuum mattress EN 1865
254225	1 x	Set Vacuum splints (arm, lower arm, leg)
220700	1 x	Inflatable tent 30 m ²
257010	1 x	Tent heater 25 kW, diesel-operated
218454	1 x	DIN power generator 6 kVA
280071	2 x	Fuel canister 20 l
221312	2 x	Cable reel 230 V, fire brigade version
221300	3 x	Telescopic tripod
258043	1 x	Folding table
258044	6 x	Folding chair
280036	2 x	Waste collector
280139	20 x	Waste sack
258038	1 x	Water canister 20 l
270555	1 x	Multipurpose fire extinguishing powder 6 kg
257600	1 x	Stepladder and leaning ladder



The state of NRW purchased 108 disaster relief vehicles in 2006. Another 50 vehicles are being purchased in 2009.



Loaded in Zarges Euro box:

Order no.	Key	Quantity	Name
259561	Box SA1	1 x	Hygiene module
		1 set	of consumables: soap, hand disinfectant, paper towels
259563	Box SB1	4 x	folding signals, marked with 1 x "BHP entrance", 1x "BHP exit", 2x "Patient tray"
		2 x	Spout for fuel canister
		2 Rolls	Red/white cordoning tape
259564	Box SB2	20 x	Aluminium shaped splints
		3 Pack	Examination gloves
		5 x	Head support
		1 x	Used needle container approx. 2.0 l
259565	Box SC1	20 x	Disposable rescue blankets
259566	Box SD1	1 x	Floodlight 1000 W
		1 x	Multiple branch
		2 x	10 m extension cable
		2 x	Tent lamp 2 x 36 W
259567	Box SD2	30 x	Disposable blanket
259562	Box SD3	25 x	NRW first aid pack for disaster organisations
259568	Box SE1	5 x	Oxygen cylinder 2.0 l
259568	Box SE2	5 x	Oxygen cylinder 2.0 l

We would be pleased to send you a detailed loading list.



Care equipment trailer

Order no.	Name	Weight kg
259510	Set, complete	780



Loosely loaded:

Order no.	Quantity/pcs.	Name
257510	1	Quick deployment tent SG300
253502	10	DIN 13024-2 stretchers
256499	1	Megaphone
258102	4	20 l containers
258116	1	25 l drinks container
258115	1	10 l drinks container
258038	2	20 l water canister
258041	1	Camping stove
258039	1	20 l cooking pot
258043	2	Folding table
258044	6	Folding chair
258048	2	Folding crate

Loaded in Zarges Euro boxes:

Order no.	Key	Quantity	Name
259511	Box BA1	1 set	Tent accessory kit
259512	Box BA2	200 x	Plastic cup
259513	Box BA3	50 x	Eating bowls (soup dishes)
259514	Box BA4	5 x	Eating bowls (soup dishes)
259515	Box BA5	50 x	Eating bowls (soup dishes)
259516	Box BA1	50 x	Eating bowls (soup dishes)
259517	Box BA7	1 x	Illumination box, consisting of: light sticks, headlights, gas lamps, signal lamps, wax flares, house- hold candles, matches, warning triangles
259518	Box BA8	1 set	First Aid kit, consisting of: respiration bag, blood pressure measuring device, rescue blankets
259519	Box BA9	1 set	Cooking accessories, consisting of: ladle, knife set, tongs, cutting boards, can opener
259520	Box BB1	30 x	Disposable blankets
259521	Box BB2	1 x	Box of spares
259522	Box BC1	200 x	Rain shield
259523	Box BC2	200 set	Eating cutlery
259524	Box BC3	1 set	Kitchen accessories, consisting of: towels, tea towels, absorbent cloths, dishwashing brushes
259525	Box BC4	1 set	Office materials
259526	Box BD1	20 x	Disposable rescue blankets
259527	Box BD2	1 set	Baby care items
259528	Box BD3	1 set	Sanitary products



Equipment trailer

Order no.	Name	Weight kg
259530	Set, complete	630

Loosely loaded:

Order no.	Quantity	Name
212813	10 x	Post
230012	8 x	Base for post
230010	3 x	Sign stands
221300	2 x	Telescopic tripods
218454	1 x	DIN power generator 6 kVA
280071	1 x	Fuel canister 20 l
221312	2 x	Cable reel 230 V, fire brigade version
270555	3 x	Multipurpose fire extinguishing powder 6 kg
280036	2 x	Waste collector
280139	20 x	Waste sack
257600	1 x	Stepladder and leaning ladder
258038	2 x	Water canister 20 l
210682	1 x	Fix-O-Mat road broom
210700	1 x	Handle for Fix-O-Mat broom
210610	1 x	Pickaxe 1.5 kg
210540	1 x	Fire brigade spade



We would be pleased to send you a detailed loading list.



Loaded in Zarges Euro box:

Order no.	Key	Quantity	Name
259531	Box TA1	1 x	Toolbox with 38-piece Tool set
		1 Set	Consisting of folding spade, box chisel, hatchet and extinguishing blanket
259532	Box TA2	1 x	Power distributor
		2 x	LED portable lamp
		1 x	Spout
259533	Box TB1	10 x	Traffic cones, folding
		4 x	Traffic warning signs
		2 x	Warning flags
		2 Rolls	Plastic cordoning tape
259534	Box TB2	2 x	Gas hot air blower
259535	Box TC1	1 x	Multiple branch
		3 x	10 m extension cable
259536	Box TC2	2 x	Floodlight 1000 W
259537	Box TD1	2 x	Tent lamp
259538	Box TD2	2 x	Tent lamp
259539	Box TD3	1 set	Illumination box, consisting of: light sticks, headlamps, gas lamps, signal lamps, wax flares, house hold candles, matches, warning triangles
259540	Box TD4	1 set	Set of treatment station signs
		1 Pack	Marking chalk
		1 Roller	Binding thread
		1 set	Cable ties
		1 x	Roofing hammer
		2 x	Hand-held stop sign
		4 x	Cordoning rope
		1 Pack	Latex gloves



Here are some examples of individual vehicle concepts:



County of Bentheim SAN equipment vehicle



LuK Märkischer Kreis equipment trailer



County of Bentheim SAN equipment vehicle



State of NRW care equipment trailer



Märkischer Kreis MANV equipment vehicle

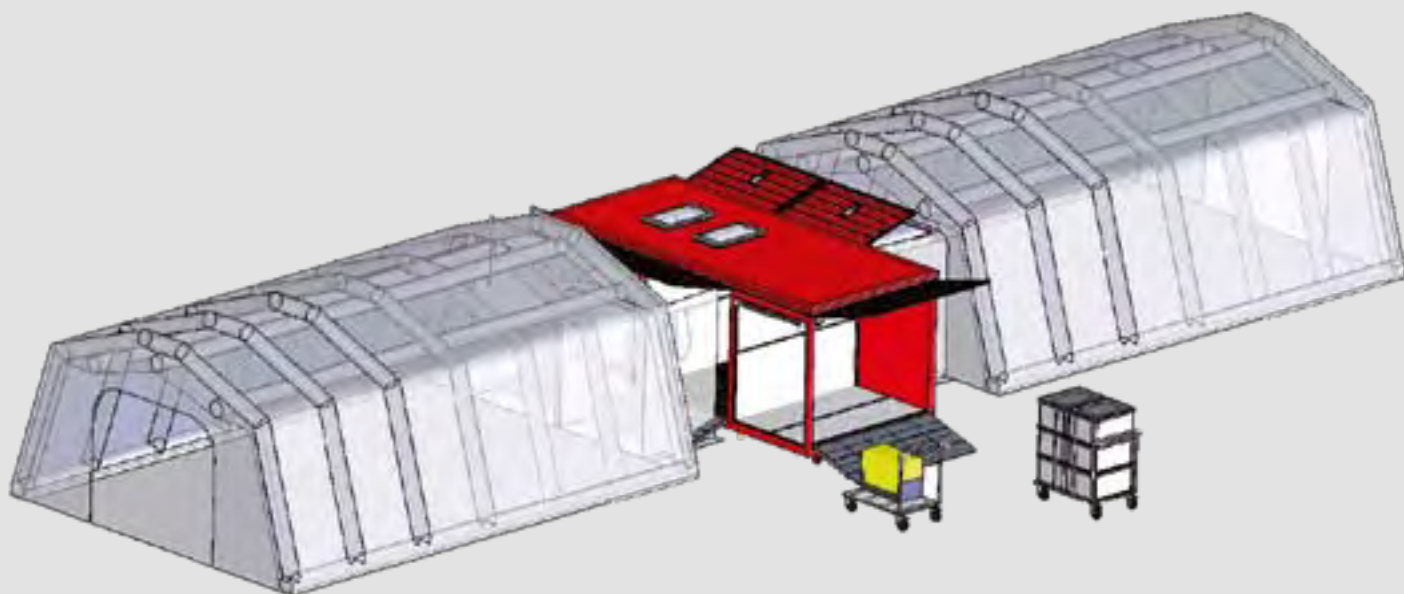

State of NRW AB Decon V swap body



Märkischer Kreis MANV equipment vehicle



SEG care with small kitchen equipment trailer



State of NRW SAN equipment vehicle



Protecting the environment and fire brigade and THW operations pertaining to this area are on the increase and are becoming increasingly important. You will find many interesting equipment items for these important operations in this chapter.



**Flood/
water protection**



Sealing materials



Decontamination

Dönges fire brigade	Spill bag	345-346
Starmix suction pump	Quick channel seal	346-347
Emergency case pump		344
Dual-chamber hose		345
Leak stop	Oil binding cloths	347
Sealing tape	Sealing set	347
Sealing hemp	Gas plug & cap set	347
Wire wool	Filtering &	348
Cleaning cloths	Clearing shovel	348
Decontamination	Waste water pump	354
cabins	Continuous heater	350-351
Decontamination showers	Storage containers	352
Basins		353
Pressurised water		
pump		353-354

Dönges fire brigade suction pump Starmix

The new Dönges fire brigade "Starmix" suction pump has been specially developed for use by fire brigades and disaster relief organisations.

Large quantities of heavily contaminated water or non-combustible liquid are sucked up without problems until they have been completely drained, and are continuously pumped out using the built-in mast pump.

A wet filter bag that is included in the scope of delivery collects coarse dirt, protects the pump and filters water that is only slightly contaminated if necessary. For pumping out, the suction pump uses a 10 m pumping hose with Geka connection for connecting to the suction pump and a Storz-C connector for connecting additional C hoses.

The suction pump can also be used as a dry suction pump without problems.

A 20 l plastic container is optionally available for dry suction.



Hook & Loop tape for securing the hose



Pressurised waterproof isolated ground receptacle



10 m connecting cable, integrated personnel protection switch



Pressurised waterproof shockproof plug



5 m special suction hose



Special pumping hose with C connector



made in Germany

exclusive

Features:

- 10 m connecting cable H07RN-F31.5 with pressurised water tight IP68 connector and personnel protection switch
- Carrying handle with practical cable winding
- Connector securing mechanism
- Pressurised waterproof equipment socket with automatic activation
- Speed regulation (2 stages)
- Overrun protection

Technical data:

Power consumption: Max. 2200 Watts including pump
 Volume flow: Max. 61 l/s
 Vacuum: Max. 248 mbar
 Container volume: Max. 55 l gross
 Weight: 26.8 kg
 Delivery capacity: Pump max. 300 l/min.
 max. 40 l/min. in suction mode
 Suction height: Max. 1.5 m in full suction mode
 max. 5-8 m in sip mode
 Delivery height: From suction pump max. 6 m
 Delivery breadth: Max. 50 m

Order no.	Item	Dimensions	Weight kg
218600	suction pump	59 x 57 x 100 cm	26,8
218601	Special plastic container	20 l	1,3



With integrated submerged pump



Tilting running gear

Emergency pump set

Time and time again, fuel or other hazardous substances have to be pumped out or pumped into another container during operations to protect the emergency services or the environment. This can be done using this compressed air double diaphragm pump, which is safely stowed away in the Dönges Firebox® together with all of the necessary accessories.

The pump is safely and reliably operated using a 200 or 300 bar breathing air cylinder, a compressor or the vehicle compressed air connection. With a capacity of 25 l/min., this pump is sufficient for the majority of operations.

Features:

- Compressed air double diaphragm pump made from diecast aluminium.
- Extremely robust, yet still extremely light (2.1 kg)
- Flexible range of uses
- Conditionally alkali and acid resistant
- 200 - 300 l pumping capacity with one breathing air cylinder
- Ready for use in a Dönges Firebox® Size 3

Scope of delivery:

- 1 x Compressed air double membrane pump
- 1 x Compressed air hose 1/2 inch, 2 m long
- 1 x Car suction hose, 10 mm, 1.5 m long
- 1 x Suction hose 3/2 inch, 2 m long, with filter
- 2 x Earthing cables with cable shoe and contact clamp, 2 m long
- 1 x Spiral compressed air hose, 7 m long
- 1 x Pressure reducer 300 bar
- 1 x Dönges Firebox® made by Zarges, size 3

Order no.	Item	Weight kg
1 221380	Emergency pump set, complete	11,6
2 221381	Double diaphragm pump, individual	2,1
214015	Firebox® DIN 14880-3-LM empty	5,1



made
in
Germany

DÖNGES
exclusive

Emergency pump

Simple but effective manual pump for pumping small quantities of liquid. Hose length approx. 2 metres

This emergency pump is amazingly effective for decanting fuel, water and liquids containing petrol or oil, for example.

Order no.	Weight kg
221386	1,0



Double chamber hose "Eco Boom"

This double chamber hose is used to collect contaminated fluids such as extinguishing water. However, the spread of oil floating on top of water can be reliably prevented using this double-chamber hose. When extinguishing water or contaminated liquid is being collected, the double chamber hose is first unrolled to the required length and cut off. The Storz dummy connectors in the complete set are secured to the cut-off end using the tension straps. Both chambers are then filled with water via the Storz connectors that are already attached at the other end. The heavy weight of the hose prevents it from floating on top of the liquid that is being collected, and the liquid is reliably held back.

Only the small chamber is filled with water when the hose is used on water. The large chamber is filled with air. Since the small chamber is now below the surface of the water a film of oil is reliably held back, even if it is only a few centimetres deep. The air chamber maintains the barrier at the surface during this time.

There are 100 m of this double chamber hose on a reel. A collecting basin for 15,000 litres of fluid can be created using this hose, for example. The complete kit consists of 100 m of double-chamber hose on a reel, two Storz connectors, two Storz dummy connectors and tension straps for securely attaching the Storz dummy connectors.

Features:

- Small packing dimensions
- Extremely light, therefore easy to transport
- Material PE, 0.2 mm

Order no.	Item	Weight kg
221352	Eco Boom Set with Storz connectors	57,0
221353	Spare double-chamber hose 100 m	38,0



Spill bag 15

Spill bags were developed in order to quickly and efficiently collect escaping liquids such as oil, coolants etc. during operations at any time. The decisive advantages of spill bags in comparison to normal emptying trays are the extremely compact dimensions, which saves a considerable amount of space in the vehicle, the self-raising principle and the liquid retention system that is built into this spill bag, which prevents the collected liquids from escaping.

Spill bag 15 is used to collect small quantities of liquid up to 15 litres. The extremely small dimensions of the spill bag allow it to be stowed in vehicles without problems.

Features:

- Material: 0.3 mm thick PE, extremely oil and chemical resistant
- Small packing dimensions
- Self-sealing, making transportation and the collected liquids safer and problem free
- Extremely light weight
- Pack size 55 x 50 x 1 cm
- Capacity 15 l

Order no.	Dimensions cm	Weight kg
221350	100 x 50 x 2	0,7

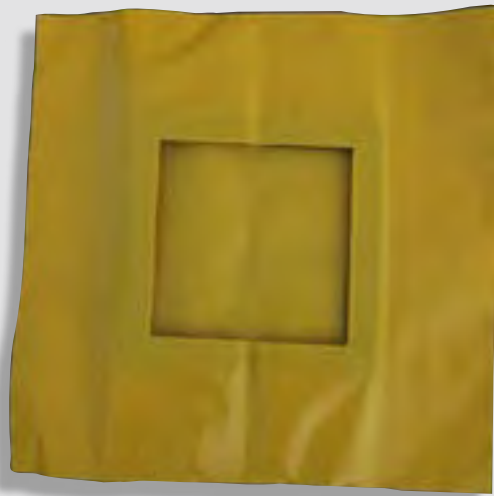

Spill bag 100

Like the spill bag 15, this "big brother" is also used to collect oil or other chemicals. It is just as easy to use, but has a considerably greater volume. The spill bag 100 does not have a built-in valve, but raises itself during use so that all liquids are reliably collected.

Features:

- Material: 0.5 mm thick PE, extremely oil and chemical resistant
- Small packing dimensions
- Self-sealing, therefore safe and problem-free use in any situation
- Extremely light weight
- Capacity 100 l

Order no.	Dimensions cm	Weight kg
221351	120 x 90 cm	2,8

Shaft cover

Tear-resistant sack made from strong PVC film, tapering towards the top. Base area approx. 750 x 750 mm. Mineral oil resistant, impermeable to liquids (plastic sack with variable shape). The sack is simply placed on the gully inlet and filled with water. There is also a foam material panel that can be placed beneath the shaft cover. This compensates for undulating surfaces in a better way, and prevents damage to the sack.



Order no.	Item	Dimensions mm	Weight kg
217860	Shaft cover	750 x 750 x 500	1,2
218550	Foam material panel	900 x 900 x 20	1,7

Tarpaulin

Heavy, multi-layer film 4 m x 6 m, mineral oil resistant, with screen fabric and eyes at the edges (approx. every 50 cm). Double, tape-reinforced edge.



Order no.	Dimensions m	Weight kg
217865	4 x 6	3,6

Polyethylene film 100 m²

Transparent rolls of film 4 x 25 m, thickness 0.2 mm, folded to a width of 1 m.

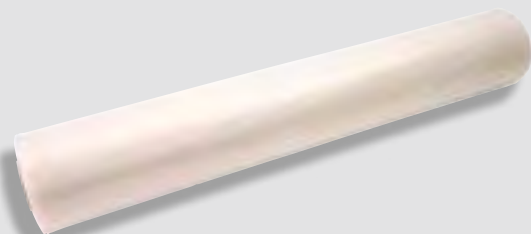

Order no.	Dimensions mm	Weight kg
214165	170 Ø x 1000	16



made
in
Germany

exclusive IDINGES

Quick gully sealing Gully-Stop

The Gully-Stop is the ideal quick sealer for emergencies. The Gully-Stop, which is filled with a mixture of water and a special antifreeze (with higher specific gravity than water) and is made from a mineral oil resistant, coated tarpaulin material, is secured to the wall in the vicinity of gully inlets using a special wall bracket and is simply taken from the wall bracket in an emergency and placed onto the gully.

The heavy intrinsic weight provides a reliable seal and prevents the Gully-Stop from floating.

The entire set consists of the Gully-Stop and a 10 litre container of antifreeze and the wall bracket.

Order no.	Item	Dimensions mm	Weight kg
218555	Complete set	700 x 700	15,9
218560	Gully-Stop, individual	700 x 700	0,8
218565	Concentrated antifreeze		
	10 litre canister		14,0
218570	Wall bracket		1,1

Sealing paste Leck-Stop



Universal sealing paste for immediate sealing of all types of leak. Can be used for petrochemical products, many chemicals, alkalis, acids, hydrocarbons, solutions and cleaning agents. Supplied in tub with screw lid.

Order no.	Capacity ml	Weight g
217455	500	600

Teflon sealing tape

Made from polytetrafluoroethylene (PTFE), 12 mm wide, Length: 10 metres.

Order no.	Weight g
217395	18



Sealing hemp



Order no.	Model	Weight g
214110	Pack in polythene bag	1000
214115	Skein, individual	200

Wire wool

Packed in Polyethylene bag

Order no.
214125Weight g
2000**Cleaning cloths**

2 kg in plastic bag, made from 100% new textile fabric, for removing coarse dirt, oil, grease and lubricants.

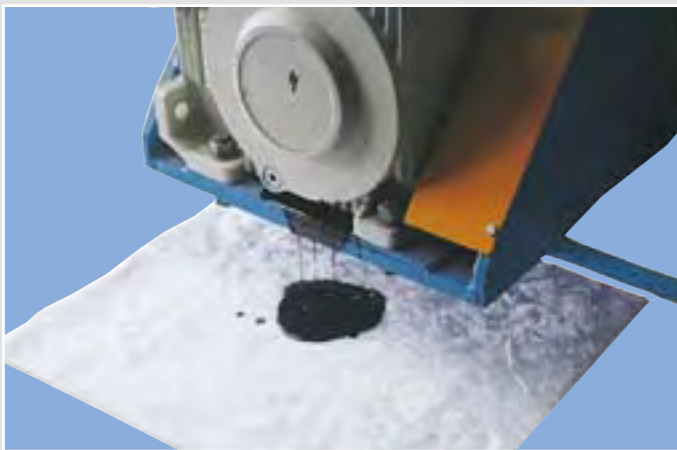
Order no. Cloth dimensions mm Weight g
280055 380 x 380 2000**S&H oil binding cloth**

For removing minor areas of oil soiling and collecting oil drips.

Oil absorbent and water repelling. Absorbs up to 25 times its own weight in oil and organic fluids. Each cloth can absorb up to 1.2 litres.

Order no. Dimensions cm Weight g
280056 43 x 48 x 0.5 25**Seal set DIN 14880**

Various aids for sealing leaks, compiled in accordance with DIN 14800-10:2005-02.

Order no.
217450Weight g
2380**Gas plug and cap set**

16-piece set, consisting of: 8 plugs with square in acc. with EN 10241-DN sizes 8 - 50 and 8 caps in acc. with DIN 10241-DN sizes 8 - 50.

Order no.
211094Weight g
1840

Sealing plug set

Version as per equipment vehicle standard DIN 14555-T3.

Wooden sealing plug 300 mm long, made from soft wood, packed in synthetic fibre bag.

Set, 12 pieces:

- 3 pcs. 90/25 mm Ø
- 3 pcs. 60/10 mm Ø
- 6 pcs. 30/10 mm Ø

Set, 20 pieces:

- 5 x 90/25 mm Ø
- 5 x 60/10 mm Ø
- 10 x 30/10 mm Ø

Order no.	Pieces	Weight g
214130	12	1800
214135	20 (Standard)	3000

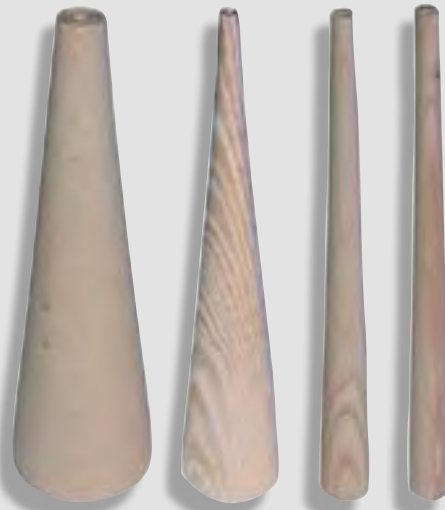

Sealing wedge set

Version as per equipment vehicle standard DIN 14555-T3. Sealing wedges 300 mm long, 70 mm high, made from soft wood, packed in synthetic fibre bag.

Set, 10 pieces:

- 2 x 50 mm wide
- 3 x 100 mm wide
- 3 x 150 mm wide
- 2 x 200 mm wide

Set, 20 pieces:

- 5 x 50 mm wide
- 5 x 100 mm wide
- 5 x 150 mm wide
- 5 x 200 mm wide

Order no.	Pieces	Weight kg
214140	10	10,2
214145	20 (Standard)	20,0

Tank securing strap with ratchet

Made from polyester, length 10 m, width 50 mm, with ratchet, tensile strength 4 kN.

Order no.	Weight g
210490	2000

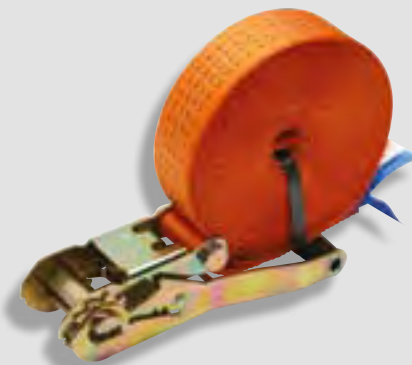

Filtering and clearing shovel

For removing binding materials and for cleaning waters of any kind. Floating shovel with detachable, two-piece aluminium handle, 2 m long, plastic frame, aluminium plug-in screen (fine screen).

Order no.	Shovel dimensions mm	Weight g
210570	280 x 360	1800





Decontamination showers

Features:

- Erected in seconds due to normal commercial breathing air cylinder or an electric Blower
- The cabin is ready for use immediately
- Clearly marked entrance (green) and exit (red)
- In order to provide an outstanding service life and optimum stability, only the best materials have been used
- Built-in shower strip with nine spray nozzles, Stopcocks and Geka connections

Scope of delivery:

- 1 x Inflatable support frame
- 1 x Groundsheet with outlet
- 1 x Shower curtain
- 1 x Shower strip with nine spray nozzles per cabin
- 1 x Pack sack
- 1 x Set of rigging materials



Decontamination cabin 100

Cabin for one person

Dimensions:

180 x 180 x 250 cm

Order no.

270750

Weight kg

45



Decontamination cabin 150

Cabin for one person with additional basin for pre-decontamination.

Dimensions:

350 x 180 x 250 cm

Order no.

270751

Weight kg

50



1 Decontamination cabin 200

Cabin for one or two persons
Ideal for NBC carriers.

Dimensions:

250 x 250 x 270 cm

Order no.

270752

Weight kg

50

1



Decontamination cabin 300

Like cabin 200 but with additional basin for pre-decontamination. Ideal for NBC carriers

Dimensions:

450 x 250 x 270 cm

Order no.

270753

Weight kg

55

2



2 Decontamination cabin 400

With two integrated shower strips.
Cabin for decontaminating persons who are lying down. Can be used for mass decontamination or as a pass-through support tasks. The first shower strip is operated with decontamination solution, and the second is used for rinsing.

Dimensions:

450 x 250 x 270 cm

Order no.

270754

Weight kg

65

3 Decontamination cabin 420

Double cabin with two separate entrances and exits.
Two people can be decontaminated at once.

Dimensions:

450 x 250 x 270 cm

Order no.

270755

Weight kg

65

3



Decontamination cabin 450

Like cabin 420 but with additional basin for pre-decontamination.

Dimensions:

450 x 450 x 270 cm

Order no.

270756

Weight kg

70

Hazmat shower

Light and compact to transport, yet still ready for use in an instant. Specially for decontaminating NBC carriers. Decontamination can be carried out without the need for additional personnel. All stainless steel.

The shower frame has 9 nozzles for distributing the decontamination solution in the best possible way.

Technical data:

Stopcock:	Integrated.
Flow rate:	36 l/min
Erection time:	15 s
Dimensions:	114 x 64 x 210 cm
Packed:	114 x 20.5 x 39 cm

Order no.	Weight kg
270757	22



Decon Circle II

Simple solution for decontaminating emergency service personnel. Compact and simple to use. The octagonal spray ring provides optimum distribution all round.

Technical data:

Stopcock:	Integrated.
Flow rate:	30 l/min
Dimensions:	Diameter 100 cm
Packed:	120 x 60 x 5 cm

Order no.	Weight kg
270758	3,8

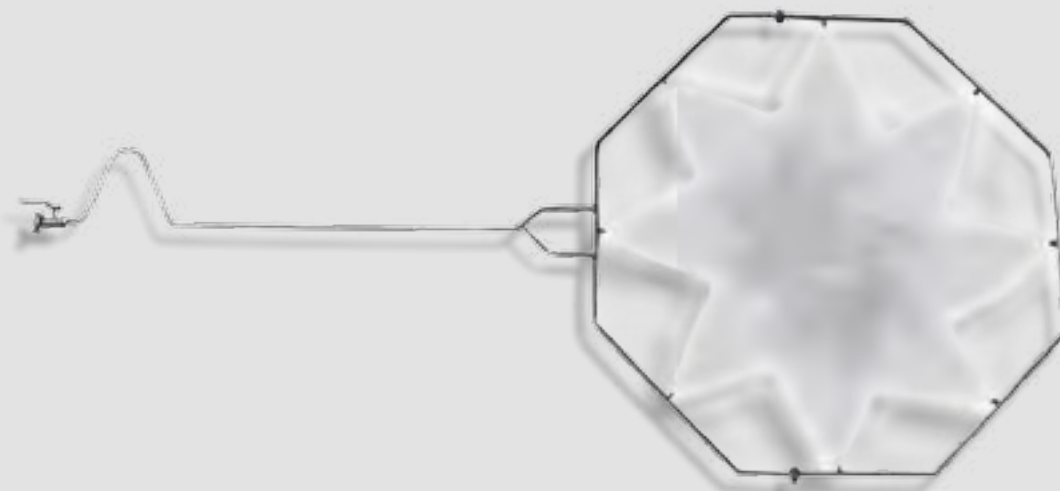

Inflatable decontamination basins

Quickly erected basin for collecting contaminated fluid or for use with the Decon Circle or the Hazmat Shower. Ready for use within no more than 30 seconds. Can be erected using compressed air cylinders or an electric blower.

The inner tray can be replaced separately.

Basin 150

Technical data:

Capacity: 400 l
 Dimensions: 150 x 150 x 25 cm
 Packing size: 75 x 40 x 10 cm

Basin 250

Technical data:

Capacity: 1100 l
 Dimensions: 250 x 250 x 25 cm
 Packing size: 110 x 70 x 10 cm

Basin 500

Technical data:

Capacity: 2800 l
 Dimensions: 300 x 500 x 25 cm
 Packing size: 150 x 100 x 40 cm

Order no.	Item	Weight kg
1 270770	Basin 150	10
2 270771	Basin 250	15
3 270772	Basin 500	32



3

Compressed air inflation kit

Needed if a decontamination cabin or pressure tent is being erected using compressed air cylinders.

Set 1

Has one connection for the pressure reducer and two outlets as inflation connections. Needed for inflating tents.

Set 2

Has one connection for the pressure reducer and one outlet as an inflation connection. Needed for inflating decontamination cabins or basins.

Scope of delivery:

- 1 x Pressure reducer 300 bar
- 1 x Connecting nipple outlet for quick-release compressed air connection
- 1 x Compressed air hose with quick-release couplings at both ends

Order no.	Version	Weight g
270713	Set 1	1500
270714	Set 2	1500

A suitable compressed air cylinder can be found on page 316



Pressurised water pump Hydrophore pump

For supplying a decontamination station with water if the water supply is unpressurised (e.g. when taking water from a water tank).

Technical data:

Water pressure: 2.5 – 5 bar
 Delivery capacity: 3500 l/h
 Dimensions: 62 x 55 x 32 cm
 Motor output: 0.8 kW
 Connections: Geka connections

Order no.

270780

Weight kg

34



Inducer mixer

Mixer for automatic metering of decontamination material or disinfectant. Adjustable mixing rate with metering scale in %. The metering adapts itself to the flow rate. The concentration of the solution always remains constant.

Features:

- Setting range 0.2 – 1.6 %
- Flow rate 10 l/h min, max. 2500 l/h
- Operating pressure 0.3 – 6 bar
- Built-in filter (300 microns)

Order no.

270783

Weight kg

1,6

Sewage water pump Waste pump

Submersible pump with level switch for pumping the contaminated liquid out of decontamination trays and shower cabins.

The entire box is placed in the collection basin.

Features:

- Fully automatic operation
- Liquid switch
- Dry running protection

Technical data:

Delivery capacity: 5400 l/h
 Dimensions: 40 x 30 x 34 cm
 Motor output: 0.25 kW
 Connections: Geka connections

Order no.

270784

Weight kg

4,1



Instantaneous water heater Hotbox 200

Powerful instantaneous water heater for generating warm water at the decontamination station. Warm water immediately after start-up, no waiting time. Fuel supply directly from the canister, no built-in tank required. Can supply up to four decontamination cabins at the same time.

A stainless steel chimney can be fitted to remove the exhaust gas.

Features:

- Can be used immediately
- Stainless steel boiler.
- Automatic temperature control
- Four warm water outlets with separate stopcocks
- Running gear with wheels and handles

Technical data:

Fuel: diesel or heating oil
 Max. consumption: 7.8 l/h
 Flow rate: 4200 l/h
 Temperature range: 20 – 70° C
 Dimensions: 62.5 x 66 x 96.5 cm
 Connections: Geka connections

Order no.	Item	Weight kg
270781	Hotbox	80
270782	Chimney for Hotbox	2



The hotbox can also be supplied directly with an inducer on request!

Folding container Fluidbag 500

Folding container for liquids.

The container consists of a robust outer sleeve with loading loops and a replaceable inner sleeve made from PE. The outer sleeve can therefore be used several times. Only the inner sleeve has to be replaced after use.

Technical data:

Capacity: 500 l
 Dimensions: 85 x 85 x 70 cm
 Folded: 85 x 85 x 15 cm

Order no.	Item	Weight kg
270785	Container, complete	4
270786	Inner sleeve, individual	1
270787	Storz-C drain valve	1
270788	Geka drain valve	1

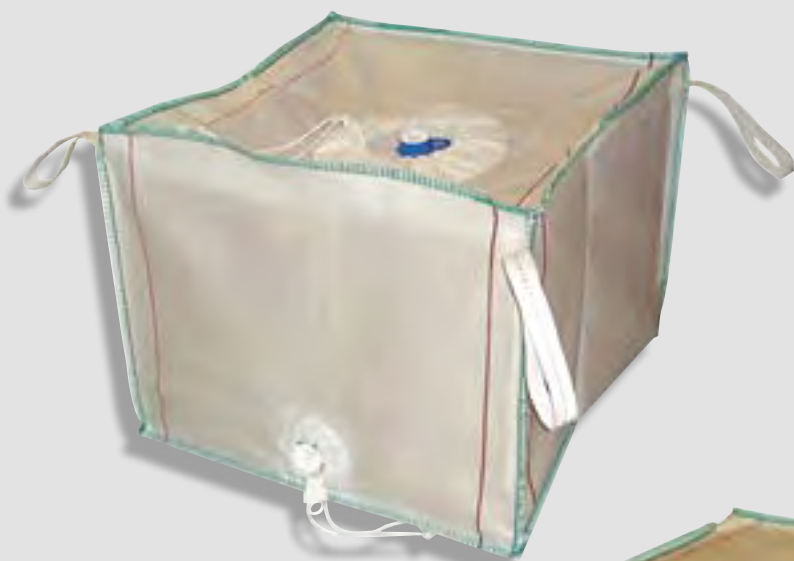

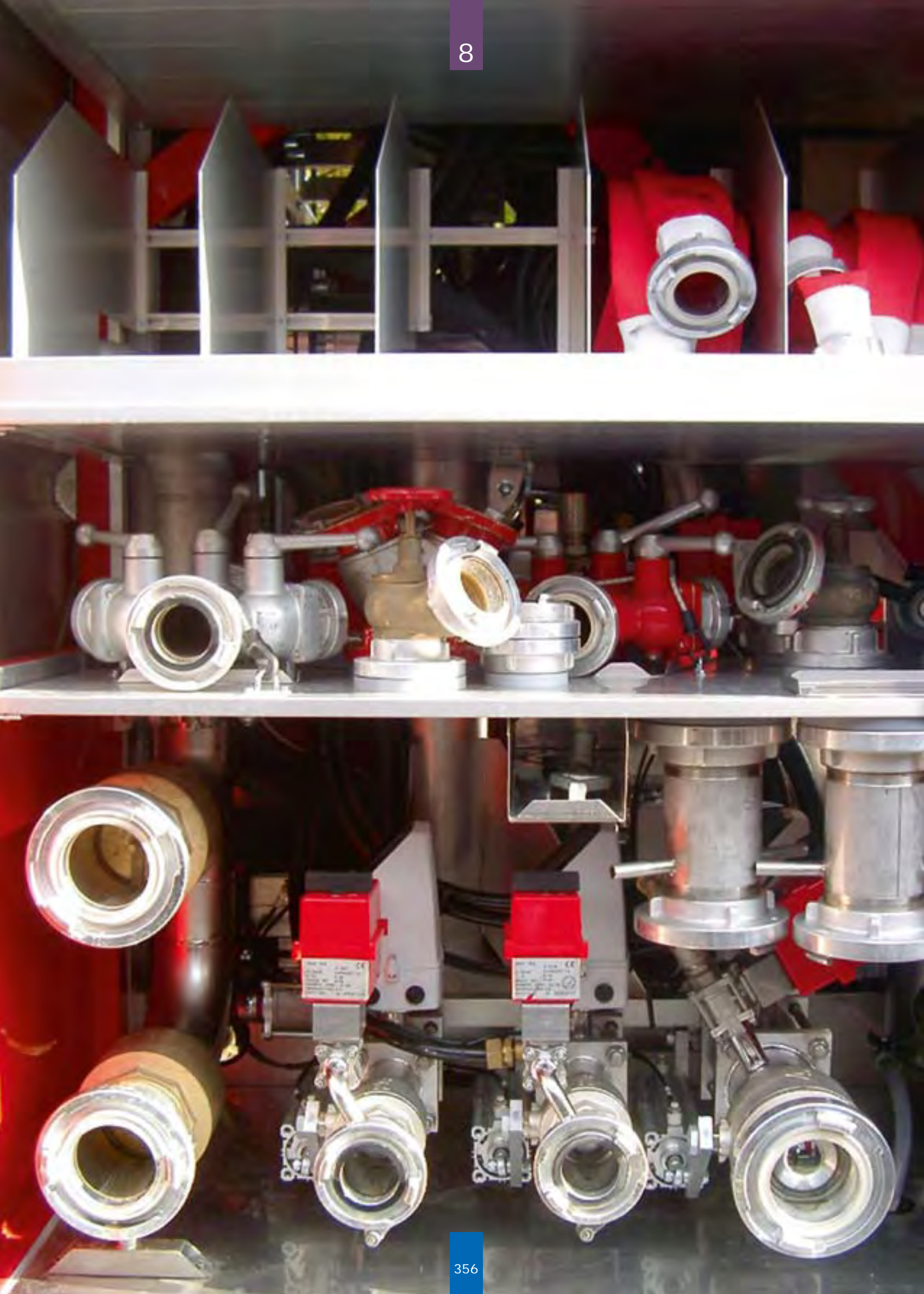

We are extremely proud of our innovative NLS spray extinguishing system, which operates with an extremely fine water spray
 You will also find products to do with extinguishing accessories, hose accessories and coupling and hydrant spanners in this chapter.



Mist extinguishing system NLS

Complete set	358-360	Fire lances	361
Special hammer	360	Three-way distributor	361



Extinguisher

Portable fire extinguishing spray	362	Bucket pump	362
		Forest fire beater	363



Fire blanket

Fire blanket	363	Container	363
--------------------	-----	-----------------	-----



Smoke detector

Smoke detector	364	Test spray	364
----------------------	-----	------------------	-----



Key

Hydrant spanner	365	Shaft hook	366
Coupling spanner	365-366	Hose holder	367



Hose bridges

Made from wood	368	Made from rubber	368
Made from aluminium	368	Crocodile	369

Mist extinguishing system NLS



An information video can be found on the Internet at www.doenges-rs.de!



Made in Sweden

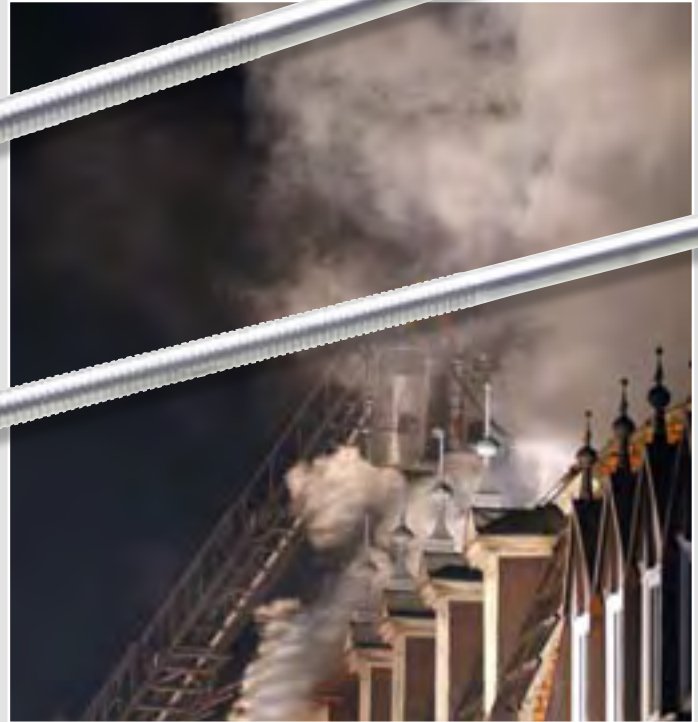

1. Faster extinguishing

These new technologies can be used in fire fighting to quickly deploy several special extinguishing lances and therefore quickly achieve the required extinguishing result.

Since neither doors nor windows need to be opened or the roof broken into in this type of fire fighting, the undesirable ingress of oxygen is avoided, which would only increase the intensity of the fire.

The fire is extinguished efficiently, since the atomised spray is sprayed into the hottest part of the fire.

The finely distributed droplets cause the water to evaporate almost completely. The greater the amount of water that evaporates, the quicker the fire can be put out.

2. Additional safety

Since this type of fire fighting avoids the introduction of additional oxygen, the risk of the fire spreading to the entire building is low. The risk of flashover is significantly lower.

However, if a flashover or explosion occurs inside the building, the risk of injury to personnel is easier to assess using this technology, because there is always a wall or roof between the personnel and the fire.

3. Less water damage

Since extinguishing takes place in the hottest part of the fire, almost all of the water evaporates. Each extinguishing lance consumes just 70 litres of water per minute with a pressure of 6 bar. The combination of rapid extinguishing success and low water consumption reduces the amount of water damage considerably.

Extinguishing with cooling water spray...

Creates resistance lines

Cools conflagration gasses during use and before ventilating takes place

Combats concealed fires

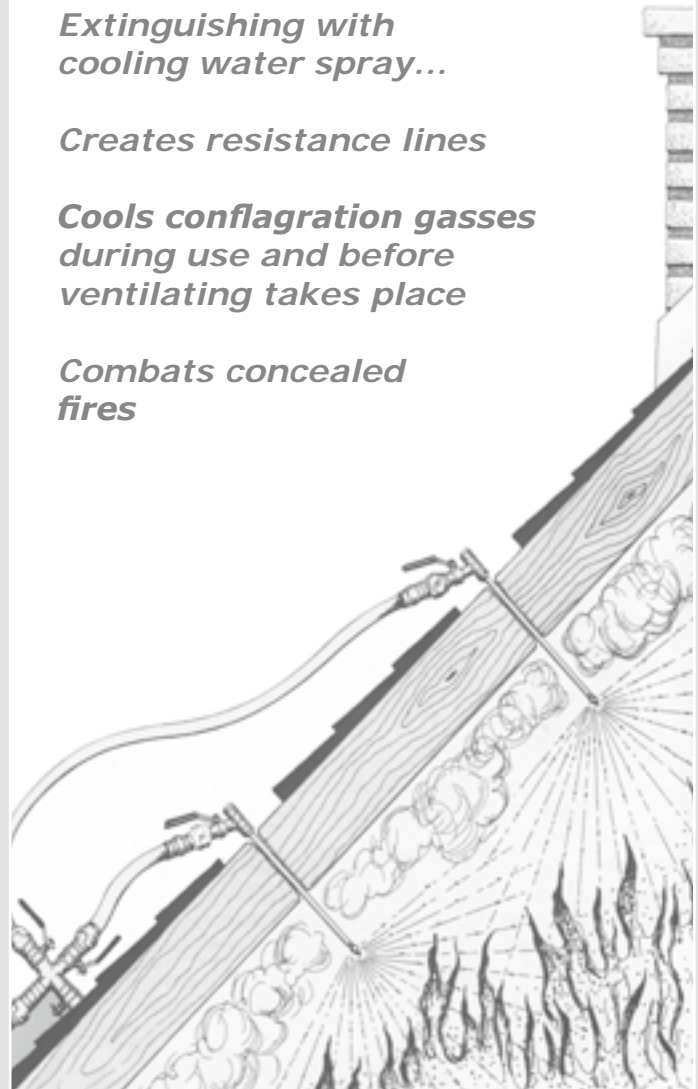



Fire in converted loft

If the fire has to be fought on the roof, several lances must be used. The attack model is screwed to the lower edge of the roof using a hammer drill and is directed upwards, against the fire. The fire can also be fought from the gables of the building.

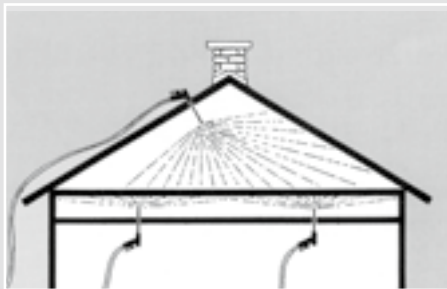

Fire in false ceiling

The fire is fought from above and below. You therefore reach all concealed fire pockets in the cavities in the ceiling structure. Just spray water into the small cavities for just 3-4 seconds with interval extinguishing.



Aircraft/vehicles/containers

When large passenger aircraft are being evacuated there is a risk that extinguishing cannot take place via the escape routes. Fires in lorries, containers, paper containers etc. can also be extinguished safely.

1 Wide angle model



Two fine nozzle rings that are exactly opposite each other provide extremely powerful atomisation.



2 m

The wide angle model generates a large curtain and is therefore extremely suitable for large-area fire source wetting.



2 Attack model



The nozzles point forwards so that a long-range spray jet is produced.



8 m



The attack model sends the spray much further, and is therefore better for accurate extinguishing when the location of the fire source is known.



Complete set Firebox® DIN 14880-1

Basic equipment for the majority of operations.

Consisting of:

- 1 x Attack extinguishing lance
- 2 x Wide angle extinguishing lance
- 1 x Special hammer
- 1 x Three-way distributor
- 1 x Firebox® size 1 (600 x 400 x 220 mm) with special insert made from waterproof wood and enough room for three D-hoses

Order no.	Weight kg
218606	15

exclusive **DÜNGES**



Supplied without hoses



Special hammer

Heavy hammer for making an opening for extinguishing lances in doors, steel tanks, roller shutters, roofing tiles etc.

Made from stainless steel, solid welded-on impact tip, rubber-coated non-slip handle, hand loop.



Order no.	Length mm	Weight kg
218635	480	2,75



Wide angle and attack extinguishing lances

Storz 25 DS claw coupling and ball taps, all other parts made from stainless steel.

Maximum operating pressure: 20 bar

Water consumption 70 l/min

Order no.	Item	Length mm	Weight kg
1 218615	Wide angle extinguishing lance	550	1,2
2 218610	Attack extinguishing lance	550	1,2

exclusive **IBÖNGES**



Three-way distributor

Three lances can be operated simultaneously via the distributor. Three Storz 25 DS couplings act as outlets. A C-type fixed coupling is fitted as an inlet as standard.

Order no.	Weight kg
218640	1,9



Portable fire extinguishing spray

Plastic water tank with capacity of 21.5 litres, screw cap and air valve for spillage-free transportation. The double-acting manual hose pump delivers 1 litre per 10 strokes and is equipped with an adjustable spray jet nozzle.

The canister can be comfortably carried as a backpack with two carrying straps and an abdominal belt. Vertical range approx. 7 m, horizontal approx. 12 m.



Order no.
210850

Weight g
2000



Bucket pump DIN 14405 A10

Hot galvanised bucket, painted red, 10 l capacity. with 5 m D-hose and couplings, Full jet pipe DK.

Order no.
210860

Dimensions mm
680 x 220

Weight g
8300



Forest fire beater

With 10 fans, each 50 mm wide, 330 mm long, made from spring steel, head made from galvanised sheet steel.

ATTENTION: Handle must be ordered separately !

Type A: with normal handle socket.

	Order no.	Model	Weight g
1	210810	Normal catch	1200
	210820	Wooden handle 2 m x 28 mm Ø	500

Type B: With quick-release catch via wing screw.

	Order no.	Model	Weight g
2	210812	Quick release catch	1300
	210820	Wooden handle 2 m x 28 mm Ø	500

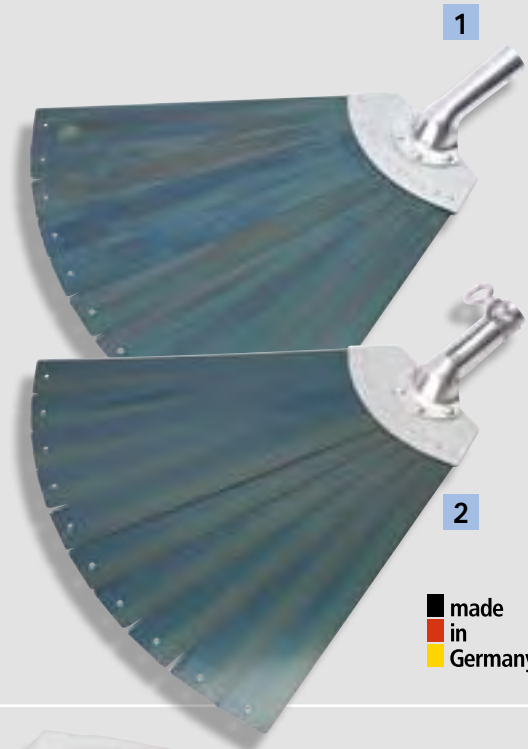

made
in
Germany

Fire blanket

Made from textured glass fabric, for extinguishing cooking oil in large kitchens, canteens, households etc. Supplied in protective sleeve. With two tabs, size 1600 x 1800 mm, asbestos-free.

Order no.	Weight g
210822	1200

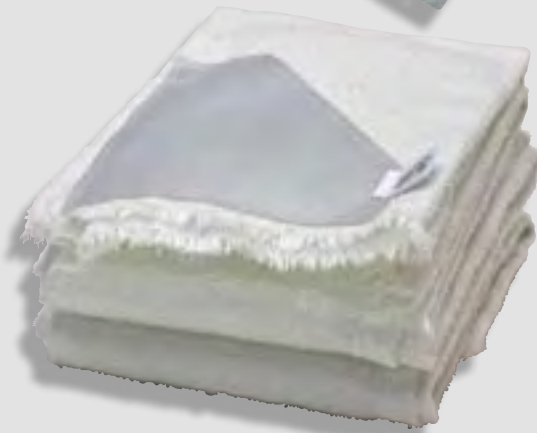

Fire blanket container

Made from sheet steel, painted red (RAL 3000) with "Extinguishing blanket" sticker and symbol.

LDB-1

Blanket is removed from below, lid held with small leather straps.

	Order no.	Dimensions H x W x D mm	Weight g
1	218824	400 x 300 x 125	3000

LDB-2

Hinges forwards, fire blanket is ready for removal in the tilted-down part.

	Order no.	Dimensions H x W x D mm	Weight g
2	210826	320 x 200 x 300	4400

LDB-3

With rotary handle, tilts forward

	Order no.	Dimensions H x W x D mm	Weight g
3	210828	310 x 310 x 150	1800



exclusive **DÖNGES**

Photoelectric smoke alarms RMO-112N

The RMO-112N photoelectric smoke detector in accordance with the new **EN standard 14604:2005** is the ne plus ultra with regard to price/performance ratio. Its identically designed predecessor (with different instructions) was adjudged to be the **second best device of its kind in issue 11/2002** of "Stiftung Warentest" (magazine published by Germany's leading consumer safety group), and therefore left the majority of considerably more expensive makes in its wake.

Features:

- VDS tested
- 5 year guarantee
- Photoelectric system
- Incl. 9 V compound battery
- With neutral presentation and cardboard packaging in a neutral colour
- Structured, easy-to-understand operating instructions, with installation site recommendations
- 108 mm Ø, 32 mm high
- Incl. mounting kit
- Production in accordance with ISO 9002

Order no.

218701

Weight g

140

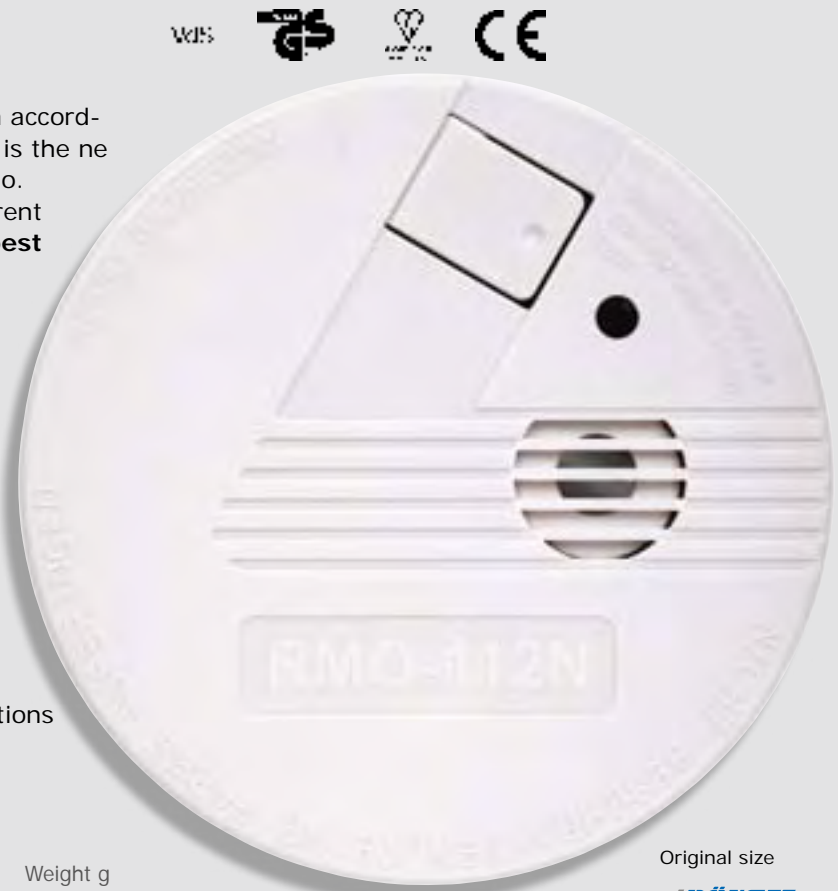

Original size

exclusive

Smoke detector test spray

Inflammable test aerosol for ionisation smoke detectors and visual smoke detectors:

Features:

- 250 ml bottle
- If it is ignited, the product breaks down into carbon dioxide
- Residue formation: clean, non-greasy, quickly evaporates
- Pressure: 20°C ~6 bar (~ 87 psig); 50°C ~11 bar (~159 psig)
- Product density: 20°C, 1.02 g/ml (63.67 lb/ft³)
- Flash point of liquid 12°C
- Vapour density (air = 1) greater than 1
- Solubility: partially soluble in water
- Flammability: inflammable/not self igniting

Order no.

218710

Weight g

140



The risk of fire must never be underestimated

About 600 people die in Germany every year in fires, the majority thereof in private households. However, unlike popular opinion, the cause of the 200,000 fires or so per annum is not just negligence: technical defects often start fires that can turn into disasters if appropriate action is not taken.

The majority of fire victims dies by suffocation

The majority of people who die in fires do not fall into the flames, but fall victim to the poisonous smoke gasses that occur during the smouldering phase. 95% of people who die in fires die of the consequences of smoke poisoning caused by the odourless gasses carbon monoxide and carbon dioxide - even just a few lungfuls of carbon monoxide are fatal.

This can happen to anyone

The majority of fire victims (70%) die during the night within their own four walls. During the day the fire can usually be discovered and put out quickly, but at night the sense of smell is also dormant, meaning that the victims are surprised in their sleep and do not notice the dangerous conflagration gasses.

Smoke detectors save lives

The RMO-112N provides advance warning of the danger before deadly conflagration gas concentrations have formed. The loud alarm warns you of the risk of fire in plenty of time even when you are asleep, giving you the advance warning that you need to get your family out of harm's way.

Hydrant spanner DIN 3223

DIN 3223-A:

For surface hydrants, made from malleable cast iron, painted red.

Order no.	Length mm	Weight g
212210	420	1200

DIN 3223-B:

For surface hydrants, made from malleable cast iron, painted red.

Order no.	Length mm	Weight g
212215	610	2200

DIN 3223-C:

For surface hydrants, made from steel, painted black.

DIN 3223-W:

For Württemberg underground hydrants (deeper than normal hydrants), made from steel, painted black.

Order no.	Model	Length mm	Weight g
212220	C	1100	6000
212225	W	1970	9000



Coupling spanner DIN 14822 steel

Made from steel, galvanised surfaces, with black insulated handles.

Order no.	Model	Weight g
1 212240	BC	300
2 212245	ABC	800



Coupling spanner DIN 14822 Annealed cast iron

Made from annealed cast iron, painted red

Order no.	Model	Weight g
1 212246	BC	400
2 212247	ABC	800

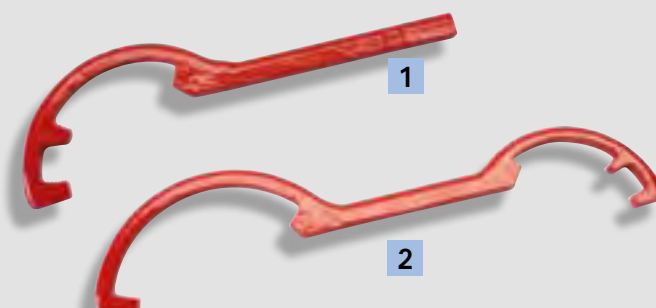

Coupling spanner, non-sparking

Made from special bronze, similar to DIN 14822, fine sandblasted surface, with black insulated handle. For use in potentially explosive areas.

Order no.	Model	Weight g
285001	BC	300

**Sickle spanner DN**

Made from stainless steel, for acid coupling in acc. with DIN 11851.

Order no.	Size	Weight g
212250	DN25-DN40	200
212255	DN50-DN100	300

Manhole hooks with chain

(Pair) made from steel, with galvanized chain.

Order no.	Weight g
212280	480

**Manhole cover lifter with handle**

For heavy manhole covers. Steel, painted black.

Order no.	Length mm	Weight g
218075	470	1200



Manhole hammer

Special hammer for levering open or opening manhole covers and hydrants. The special shape and sturdy design make it easy to open even the stiffest of manhole covers

Order no.	Length mm	Weight g
218078	320	500



made
in
Germany

Rope hose holder DIN 14828

Made from polyester, with spiral plaiting, wooden toggle at one end, eye splice at other end.

Order no.	Ø mm	Length m	Weight g
212670	10	1,6	190



Belt hose holder DIN 14828

Hot galvanised fittings, belt made from brand name polyamide.

Order no.	Length mm	Weight g
212680	350	600



Hose carrying belt

Electro-galvanised fittings, wear-resistant belt made from synthetic materials, continuously adjustable for any hose size.

Order no.	Length mm	Weight g
212690	800	240

DÖNGES
exclusive





Wooden hose bridge DIN 14820

For two B pressure hoses or two C pressure hoses, made from spruce, painted red, with white out-of-line ends.

The belts, made from UV stabilised polypropylene, are permanently stitched and secured with stainless rivets and galvanised steel plates.

Order no.	Length x Width mm	Weight kg
211710	935 x 700	11,5

Aluminium hose bridge DIN 14820

Light, handy hose bridge with tremendous load-bearing capacity.

The bridges are prevented from moving sideways by rubber profiles.

For an additional charge they can be supplied with an axial securing mechanism and a handle recess (model AS).

Features:

- Weather resistant
- Maintenance free
- Non-slip surface

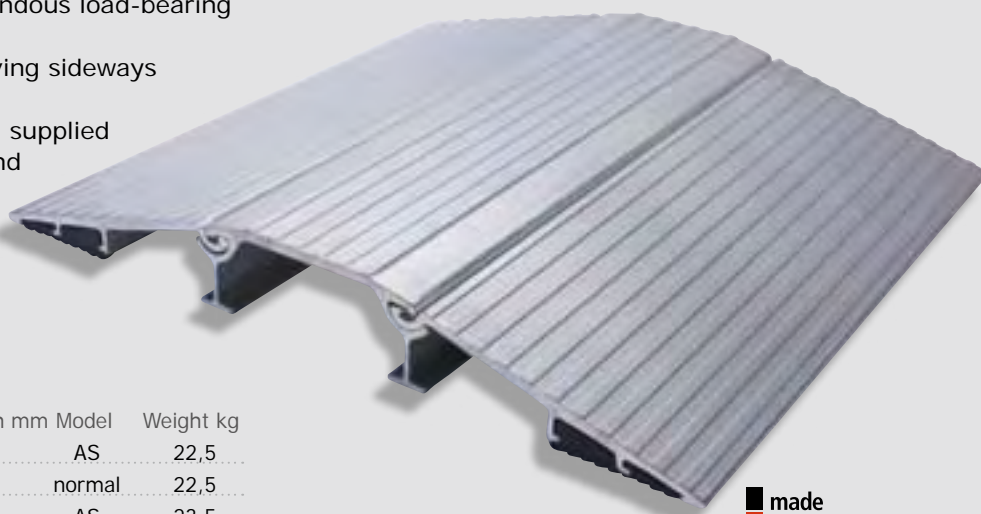

made in Germany

Order no.	For hoses	Length x Width mm	Model	Weight kg
211713	2xB, 2xC, 2xD	745 x 700	AS	22,5
211714	2xB, 2xC, 2xD	745 x 700	normal	22,5
211715	1xA, 2xB, 2xC, 2xD	860 x 600	AS	23,5
211716	1xA, 2xB, 2xC, 2xD	860 x 600	normal	23,5

Rubber hose bridge

Safety hose bridge with interlocking connecting parts that also serve as handles. Can be adapted to uneven surfaces.

With reflective stripes.

For two B pressure hoses or two C pressure hoses

Order no.	Length x Width mm	Weight kg
211711	860 x 300	13,0

For two A hoses

Order no.	Length x Width mm	Weight kg
211712	1000 x 300	20,9



Hose bridge Crocodile

The **Crocodile** hose bridge is extremely robust and durable. The knobs that are fitted as standard prevent the hose bridges from falling apart when they are assembled.

The all-rubber folding hose bridges are assembled in seconds.

The axle of the hose bridge is screwed to a rust-proof wire cable and therefore remains flexible, even if the ground is uneven.

Features:

- Made from black rubber
- Crosspieces prevent slipping
- Reflective strips on sides
- Tested with loads of up to 40 t
- Made in Switzerland

Technical data:

	Type B	Type A
Laid-out length:	890 mm	1,200 mm
Folded length:	455 mm	620 mm
Wide ramp:	300 mm	300 mm
Width including knobs:	368 mm	368 mm
Height lying flat:	95 mm	132.5 mm

Order no.	Model	For hoses	Weight kg
211717	B	2 x B	11,5
211718	A	2 x A	20,0



Advantages compared to conventional bridges:

- Handling during assembly and dismantling is extremely ergonomic for the carrier because of the folding hose bridge and the carrying handle
- Two hose bridges can be carried by one person in one hand
- Space-saving storage in the depot or on the fire engine thanks to the folding principle
- Compatible with other normal commercial rubber hose bridges
- The reflecting strips increase visibility at night and during the day
- Protection from slipping, particularly on loose surfaces, has been increased by fitting crosspieces at the bottom.

Usage options:

As a hose bridge by fire brigades, industry and event organisers. As a conduit for electric cables and power cables.



The crocodile only takes up about half as much room in the vehicle as conventional bridges



One person can carry up to four hose bridges on their own.

A			
Abseiling spider	275	Blacksmith's chisel	80
Accident cover	279	Blanket	278, 331
Accommodation tent	315	bag	331
Adapter cable	214	set	169
Adhesive		Blood pressure measuring device	294
fabric tape	189	Blower	307, 317
tape	189	Bolt cutters	103, 112
tape dispenser	189	Boots	61
Adult ventilation bag	246	Boston splint	270
AED	259-260	Bow saw	108
Air		Box	122-124
bulb masks	248	Breathing	
distributor	320	air cylinder	77
hose	317, 320	protection holster	73-74
Airbag securing system	170	protection mask	54
Airshelter	306-312	Broom head	117
Alkaline battery	192	Brooms	117-118
All-purpose expansion plug	186	Bucket	183
All-rubber		Bucket pump	362
cable reels	201-205	Bung wrench	106
distributor	208-210	Buster tool	85
drive-over ramp	178		
Aluminium		C	
basket	136	Cable	216
box	129, 133-136	hoist	173-174
hose bridge	370	reel	201-205
partition wall set	131	ties	188
Ambulance blanket	278	Calibration unit	342
Angle grinders	155	Camp bed	330
Angular plug	218	packing sack	331
Army canister	182	Camping stove	327
Ashlar fork	116	Canisters	182, 329
Attaché insert	130	Canvas bucket	183
Automatic glass punch	29, 168	Cap knife	25
Automatic knife	18	Capnograph	258
Axe	84, 87-88, 112	Care equipment trailer	336
		Car first aid kit	294
		Carpenter's crowbar	92
		Carrying	
		belt	367
		chair	271
		cloth	276-277
		rope	72
		Case	125-128
		CEE plug-in device	219
		Ceiling hooks	109-110
		Cervical support	263
		Chair	332
		Chalk	
		gravity marker	76
		marking spray	243
		Channel support	179
		Charger	193
		Chemical protection	
		gloves	60
		overall	62-64
		ChemLights	236-240
		Child respiration bag	247
		Child's cuff	294
		Chimney tool box	142
		Chisel hand guard	82
		Chisel mallet	153-154
		Chisel SDS-max	154
		Circular sling	175
		Clamping device	96
		Claw hammer	83
		Cleaning cloth	348
		Clearing	
		shovel	349
		trough	175, 184
		Clipboard	302-303
		Clip lifter	107
		Clothes hanger	68-69
		Clothing	
		bag	75
		scissors	292
		Club hammer	81
		Coffee	
		container	328
		cup	326
		Cold light laryngoscope	252-253
		Collection basin	355
		Combination	
		pliers	101
		spanner	105
		Company first aid box	295
		Compass	76
		Composite clamp	188
		Compressed air tent	308-312
		Connecting	
		cable	215
		socket	218-219
		tarpaulin	307, 313
		Construction	
		strut	179
		wrench	100
		Consumables box	145
		Continuous heater	355
		Cooker	327
		Cooking	
		crockery	325
		pot	327
		spoon	324
		Copper hammer	81
		Cordoning	
		chain	243
		equipment set	241
		post	106
		tape	243
		Corner pipe clamp	102
		Corpse	
		blanket	279
		cover	279
		Coupling spanner	365-366
		Cover lifter	366
		Cramp iron	188
		Crockery	323-325
		Crocodile	369
		Cross-cut saw	108
		Crowbar	92
		Cruiser Mate	302
		Cups	326
		Cutlery	324
		Cutter	161-162
		Cutting disks	155
B			
Backboard	264-265, 267		
Bag	34, 71, 75		
for knife	23		
Ballast tank	307, 313		
Basin	175, 184, 353, 355		
Basket	136		
Basket stretcher	274-275		
Battery	192		
Beaker	326		
Beer tent set	332		
Bell	95-96		
Belt	70, 73		
bag	34		
cutter	25-27, 168		
hose holder	367		
knife	25-27, 168		
system	266		
Bench	332		
Binding			
rope	181		
wire	188		
Bit box	150		
Bitting gauge	100		

Cutting torch	163
Cylinder binding belt	349

D

Decontamination	
basin	353-355
circle	352
mixer	354
pump	354
shower	350-352
Decorative hatchet	16
Defibrillator	259-260
Delta box	206-207
Demolition hammer	153-154
Diagonal cutting	
lead sealing pliers	101
nippers	101
Diamond cutting disk	156
Digging shovel	114
Disaster bag	288
Discharge	182
Display tray	326
Disposable	
carry blanket	277
glove	60
patient blanket	278
protective clothing	62
Distance meter	160
Distributors	206-210
Diver's lamp	42-45
Door ram	94
Double	
canisters	182
chamber hose	345
head stethoscope	294
open ended spanner	105
ring spanner	105
Dowels	186-187
Drinking water canister	329
Drinks container	328
Drive-over	
plank	178
ramp	178
Driver's logbook	300, 301
Dry	
box	122
wall screws	186
Dung hoe	116

E

Ear plugs	53
Earthing	
lead	225
Espike	225
Easy-Zip-It	291
Eating	
crockery	323
cutlery	324
Eco Boom	345
Edge	
protector	175
rider	175

Elaston broom head	117
Electric	
heating fan	318
tool box	141
Emergency	
hammer	27, 168
pump set	344
rucksack	282-286, 297-299
Endotracheal tube	254
Engineer's hammer	80
Environmental damage box	146
Equipment	
trailer	335-337
vehicle	335
Euro box	129
Exhaust hose	225
Expansion plug	186
cable	212-214
Externally mounted equipment plug	217-219
Extinguishing	
blanket	363
blanket container	363
lances	361
Eyewash bottle	292

F

Fan filter suit	64
Feeding line	215
Fibre glass	
axe	112
bolt cutters	112
ceiling hooks	110-111
fire rake	113
ripping hook	111
Field rescue equipment	285-286
Film	348
Filter	65
Filtering shovel	349
Finger sensor	257
Fire	
beater	363
blanket	363
bucket	183
detector	364
Portable fire extinguishing spray	362
rake	113
box	133-136
Fire Brigade	
axe	87-88
chrome plated hatchet	16
floodlight	194-196
halogen floodlight	194-196
hatchet	16
karabiner	72
knife	17-20
rope	71
rope bag	71
Rucksack	75
safety belt	70
spades	115
Fire Brigade	
suction pump	342-343

Fire Brigade	
vacuum	343
warning device bag	76
FireStay support	180
First Aid	
bag	289
box	294-296
kit	294-296
scissors	292
Fix-o-mat	118, 119
Flag	233
Flare set	241
Flashing light	230
Flat	
chisel	82
sack	184
Floodlight	194-196
Fluid bag	355
Folding	
container	355
direction board	231
signal	231-232
traffic cone	229-230
chair	332
spade	115
Food	
container	328
storage box	326
Foot-operated suction pump	255
Force rescue equipment	85
Forest	
fire beater	363
worker kit	53
Frame tent	315
Funnel	183

G

Gable connector	15
Gas	
cooker	327
cylinder	316
heating fan	318
Gedore tool assortment	147
Generator	220-224
Glass	
lifter	167
management set	167
master	166-167
master pocket rescue tool	17
punch	29, 168
saw	166-167
Goggles	54
Gojak	164
Gravity knife	18
Greifzug	173-174
Grinding disk	155
Ground-level hydrant wrenches	365
Guedel tubes	254
Gully cover	346-347
cover lifter	366
stop	347

H

Halogen floodlight	194-195
Hammer	
club hammer	81
copper	81
drill	151-154
drill accessory kit	152
emergency	168
engineer's	80
for NLS	360
manhole cover	83, 367
roofing	80
rubber	81
sledge	80
wood	81
Handheld	
floodlight	51-52
glove	55-60
glove clip	58
guard for chisel	82
hatchet	83
lamp	31-33, 38-47, 51-52
saw	108
suction pump	255
tape dispenser	189
HangAir	68
Hatchet	16, 83-84
decorative	16
fire Brigade	16
protective bag	16
Hay fork	116
Headlamp	48-50
Head support	267
Heater	318-321
Heating unit	321
Helmet	
holder	35-37
lamp	31-33, 48-50
Hemp	347
rope	181
Hexagon	
nuts	187
wood screws	186
HID floodlight	196
High altitude rescue rucksack	287
High voltage cable	212-214
HMS karabiner	72
Hoe	116
Hoist	173-174
Hoisting strap	175
Holder for cordoning tape	242
Holstein sand shovel	114
Holster	34, 73-74
for knife	23
reel-in	23
Hooligan tool	90-92
kit	94
Hose	
bridge	368-369
carrying belt	367
holder	367
Hotbox	355
HQI floodlight	196

Hydrant spanner	365
Hydrophore pump	354
Hygiene module	329

I

Identification vest	235
Inducer	354
Inflatable tents	306
Information sign for AEDs	261
Infusion tripod	272
Inner pocket	290
Inspection lamp	40
Intubation bag	253
Iron wire	188

J

Jig saw	157-159
Joist hanger	187

K

Kangaroo bag	288
Karabiner	72
Kelly tool	91
Kitchen hatchet	83
Knife	
automatic	18
bags	24
belt	25-27, 168
cap	25
chain	24
Fire brigade	17-20
glass master	17
holster	23
PRT	17
RT-I	18
RT-III	20
sheath	23
spiral cable	24
Kuhfuss	92

L

Ladder	165
Ladle	327
Lamp tripod	197-198
Laryngoscope	252-253
Larynx mask	254
Laser distance meter	160
Lead sealing pliers	101
Leak stop	347
Leaning ladder	165
Life hammer	168
LightShapes®	239
Light stick	236-240
Lithium battery	192
Loadout case	126-128
Lock	
picking tool box	97, 143
picks	94
set	131

Low voltage generator	220-224
-----------------------	---------

M

Magnetic clamp	225
Manhole	
brace	179
cover	346-347
Cover hammer	83, 367
Manoeuvring aid	164
Marking	
chalk	76
spray	243
Marquee set	332
Marshalling stick	240
Matador	101
Matches	241
Mazzoni	347
McLeod tool	113
Medical	
box	294-296
Rucksack	282-286, 297-299
Trailer	335
Megaphone	332
Metal	
bow saw	107
box	148
profile cylinder lock	100
vapour discharge lamp	196
Mist extinguishing system	358
Mixer	354
hooligan tool	93
organizer	301
pocket	74
tool	21-22
Multifunction	
axe	84-85
hatchet	84
hooligan tool	90
spanner	100
Multipurpose	
bucket	183
cable	165
hoist	173-174
rope	71

N

Nails	186
Neck brace	263
NiMH battery	193
Non-sparking tools	
bung wrench	106
chisel	82
club hammer	81
corner pipe clamp	102
coupling spanner	366
engineer's hammer	80
pickaxe	116
screwdriver	107
slip joint pliers	102
spades	115
square point shovel	114

Non-sparking tools	
stillson pipe clamp	102
tool set	147
Nupla-	
axe	112
bolt cutters	112
ceiling hooks	110-111
fire rake	113
ripping hook	111
Nurse's stethoscope	294
Nut box	104
Nuts	187

O

Oil	
binding cloth	348
block	345
heating fan	319-321
One-man door ram	94
Open end spanner	105
Opening tool	95-99, 143
Operations	
head of operations bag	75
bag	288
vest	235
Overall	62-63
Oxygen	
box	129
box (MANV)	251
cylinder	77, 249
reservoir	247
supply bag	249

P

Panel saw	108
Parallel vice	101
Partition	130-131, 313-315
Passenger airbag safety catch	171
Patient blanket	278
PAX	280-290
PEEP valve	247
PE flat sack	184
Percussive Rescue Tool	93
Perforated	
bracket	187
plate	187
Personnel Marker Light	240
Petrol canister	182
Plassava broom head	117
Pick	116
Pickaxe	116
Pick set	94
Pieces of wood	176
Piercing saw	108
Pillow	278
Pinching bar	92
Pin punch	82
Pioneer shovel	114
Pipe clamp	102
Pitchfork	116
Plank	177-178

Plasma cutter	161-162
Plastic fuel canister	182
Plastic shovel	115
Plate	323
Platform	164
Pliers	
combination	101
corner pipe	102
pipe	102
slip joint	102
Plug	219
Pneumatic tent	308-312
Pocket	
clip	34
knife	24
rescue knife	17-20
rescue tool	17
Polyamide rope	181
Polyethylene film	346
Portable	
forest fire spray	362
spray	362
workshop lamp	52
Post wrench	106
Power	
distributor	206-210
socket strip	207
PP shovel	115
Practice dummy	333
Press-in dowel	187
Pressure	
compressed air filling kit	316, 353
reducer	250
tents	308-312
Pressurised gas cylinder	316
Presswater pump	354
Protective bag for axe	88
PRT	
kit	93
tool	17
Pry axe	84
Prying tool	84
PTFE sealing tape	347
Pulaski axe	112
Pull clamp	188
Pulling device	96
Pull-in sock	61
Pulse oximeter	256-258
Pump	344, 354
Pump set	344
Punch	82

Q

Quick lift	180
------------	-----

R

Rain	
proof clothing	67
proof jacket	67
proof trousers	67
Ram	94

Ratchet box	104
tightening belt	181
Reanimation board	261
Rechargeable	
battery	193
floodlight	52, 199, 200
hammer drills	151
jig saw	157
portable floodlights	51
redi mate LED	303
redi rite	302
screw driller	149-150
screwdriver	149-150
Reel-	
in sheath	23
up holster	23
Rescue	
axe	86
blanket	276-277, 279
board	264-267
cloth	276-277
corset	263
disc	156
hatchet	84, 85
knife	17-20, 27
line	71
mallet	27, 168
platform	164
rucksack	297-299
scissors	28, 293
stretcher	264-267
tool	18-20, 86
Respiration bag	246-247
Res-q-me	27
Reusable crockery	323
Rib nails	186
Ring spanner	105
Ripping hook	111
Road sweeping broom	117
Roller	177
Roofing hammer	80
Rope	71, 181
bag	71
hose holder	367
Rubber	
cable	216
hose bridge	368-369
mallet	81
squeegee	117
Rucksack	75, 282-286, 297-299

S

Safety	
belt	70
blanket set	169
boots	61
cable	211
cap	219
clothing	67
contact connector	218
contact socket	217-218
glove	60

S

Safety	
goggles	54
helmet	53
operations bag	16, 88
overall	62-64
voltage tester	160
Sand	
plate	178
shovel	114
Saunders	302
Saw	
blade	158
bow saw	108
compass saw	108
handheld	108
long saw	108
metal saw	107
tree saw	108
Scissors	28
Scoop stretcher	271
Screw driller	149-150
Screwdriver	107, 149-150
Screws	186
SDS-max chisel and drill	154
Sealing	
hemp	347
paste	347
plug set	349
set	145, 348
tape	347
wedge set	348-349
Secretion pump	255
Serving	
dish	325
spoon	324
Set of	
lock picking tools	95-99
wooden supports	177
Shackle	185
Shaft	
cover	346-346
cover lifter	366
hook	366
Shaped wood set	176-177
Sheet metal	
fuel canister	182
ripper	93
Shoulder belt holster^t73	
Shovel	
bavarian	114
digging	114
pioneer	114
PP	115
sand	114
square point	114
Shower	350-352
Sickle spanner	366
Side dish	325
Signalling torch	47
Signal vest	234
Sign stand	242
Silicone mask	248

Single-handed knife	18-19
Skein	347
Sledge hammer	80
Sling	70
Small part box	131
Smoke detector	364
Snapak	303
SnapLights™	239
Socket	61
set	217-218
set	104
SOS Rescue Tool Kit	86
Soup bowl	323
Spades	115
Spare filter	65
Spar protector	169
Special	
glass centre punch	29, 168
hammer	360
Speedclip Safe	266
Spider strap	266
Spike	242
Spill bag	345-346
Spinal board	264-267
Spiral cable	24-25
Splint	270
Splitting	
hammer	89
wedge	89
Spray	362
Spring	
centre punch	29, 168
glass centre punch	168
Square point shovel	114
Squeegees	117
Squeegee system	164
Stacking	
box	120
case	121
Stand for signs	242
Steel winch	179
Stethoscope	294
Stillson pipe clamp	102
Stop chain	176
Storage stand	273
Stretcher	272
storage stand	273
Strong wind	
flare set	241
matches	241
Suction	
catheter	255
lifter	167
pump	255, 269, 342-343

T

Table	332
Tarpaulin	346
Task force tent	306-312
Tea canister	328
Team tent	315
Teflon tape	347

Telescopic	
ladder	165
tripod	197-198
Tension belt	181
Tent	
fan	307, 317
frame	315
heater	318-321
light	322
permanent fan	306
pneumatic	308-312
pressure tent	308-312
team	315
Thermal blanket	278
Thermophore	328
Threaded bar	187
Three-way distributor	206-207, 361
Timber	177
TNT tool	91
Tool	
box	129, 133-136, 148
box, metal	138-139
box, wood	140
cabinet	147
case	129, 133-136, 148
set	138-140, 147
Torch	31-47
Towing cable	185
Traffic	
accident box	144
cone	228-230
Transport	
basket	136
crate	129, 133-136
roller	177
stacking box/case	120
Tray	272
Tree saw	108
Tripod	197-198
Tuff Writer	302
Turtle	178

U

UK lamp	31-45
UltraBox	123-124
UltraCase	125
Underground hydrant wrenches	365
Unilite head	34
Universal	
blanket	278
charger	193

V

Vacuum	342-343
mattress	268-269
rails	270
VDE toolbox	141
Vehicle	
bracket	181
first aid kit	294
flashing warning lights	233

Vehicle manoeuvring aid	164
Ventilation mask	248
Vice	101
Voltage tester	160

W

Waders	67
Wall cabinet for AEDs	261
Warm air hose	320
Warning	
device bag	76
flag	233
flashing lights	233
lamp	34
operations vest	234
tape	243
triangle	233
Washers	186
Wasserkuppe	282-285
Waste	
container	184
pump	354
sack	184
water pump	354
Water	
canister	329
pump pliers	102
squeegee	117-119
Watertight	
box	122-124
case	125-128
Wax marking chalk	76
Wedge	89
Welder's	
gloves	59
safety goggles	54
Westcoast bar	91
Winch	179
support	180
Window	
breaker	27
element	314
wiper	119
Wire	188
Wire	
cutters	103
pins	186
wool	348
Wood-	
axe	88
connector	187
hose bridge	368
mallet	81
plug set	349
screws	186
wedge set	348-349
Wooden supports	176
Woollen blanket	331
Working	
glove	55-59
lamp	31-33, 38-52
light	194-196, 199-200, 322

Working	
platform	164
rope	71
Workplace floodlight	199-200

Z

Zarges box	129-136
Zieh-Fix	96-99, 143
Zip fastener extension	291

DIN

DIN 338 Twist drill	152
DIN 571 Wood screws	186
DIN 838 Ring spanner	105
DIN 934 Nuts	187
DIN 976 Threaded bars	187
DIN 1041 Engineer's hammer	80
DIN 1042 Sledge hammer	80
DIN 1052 Wood connector	187
DIN 1151 Nails	186
DIN 3110 Open end spanner	105
DIN 3113 Combination spanner	105
DIN 3222 Cordoning post	106
DIN 3223 Hydrant spanner	365
DIN 4071 Plank	177
DIN 4124 Channel brace	179
DIN 5107 Blacksmith's chisel	80
DIN 5128 Rubber mallet	81
DIN 5131 Hatchet	83
DIN 5231 Slip joint pliers	102
DIN 5241 Edge pliers	101
DIN 5244 Combination pliers	101
DIN 5265 Screwdriver	107
DIN 5299C Fire brigade karabiner	72
DIN 6450 Pin punch	82
DIN 6453 Flat chisel	82
DIN 6458 Punch	82
DIN 6473 Bow saw	107
DIN 6475 Club hammer	81
DIN 7239 Roofing hammer	80
DIN 7244 Hand saw	108
DIN 7250 Punch	152
DIN 7258 Piercing saw	108
DIN 7294 Woodcutting axe	88
DIN 7355 Steel winch	179
DIN 7462 Wooden mallet	81
DIN 7961 Cramp irons	188
DIN 9021 Washers	186
DIN 13024 Stretcher	272
DIN 13044 Belts	272
DIN 13155 First Aid	298-299
DIN 13157-C First aid kit	295
DIN 13164-B Car first aid kit	294
DIN 13169-E First aid kit	295
DIN 14060 Basin	184
DIN 14142-K First aid kit	134, 296
DIN 14405 Bucket pump	362
DIN 14572 Exhaust hoses	225
DIN 14640 Standard journal	197-198
DIN 14683 Tripod	198
DIN 14685 Power generator	221

DIN 14800-4 Chimney set	134, 142
DIN 14800-5 Multipurpose hoist	134, 173-174
DIN 14800-9 Tool kit	135-140
DIN 14800-10 Seal set	135, 145, 348
DIN 14800-11 Lifting cushion accessories	135
DIN 14800-12 Lock tools	97, 135, 143
DIN 14800-13 Road accident	135, 144
DIN 14800-14 Consumables	136, 145
DIN 14800-15 Environmental damage	136
DIN 14800-BS Cutting torch	163
DIN 14800-DK	135, 145
DIN 14800-HZK	135

EN

EN 131 Ladders	165
EN 166 Eye protection	54, 144
EN 169 Welding protection	54
EN 352 Hearing protection	53
EN 388 Gloves	56-59
EN 397 Industrial helmets	53
EN 397 Safety helmet	53
EN 471 Warning clothing	67, 234
EN 795 Anti-fall protection	70
EN 1492 Slings	173-175
EN 1731 Eye protection	53
EN 1865 Stretchers	263-277
EN 1869 Fire blanket	363
EN 12941 Respiratory devices	64
EN 14605 Protective clothing	
against liquid chemicals	64
EN 50146 Cable ties	188
EN 60309 Plugs/couplings	219
EN 61316 Cable reels	201

Impression:

Issued by: Dönges GmbH & Co. KG
Jägerwald 11, D-42897 Remscheid

Copyright: Dönges GmbH & Co. KG

Editorial team: Stefan Gowitzke, Thomas Pletsch,
Klaus Schneider & Klaus Trusheim

Graphics: Birgit Zimmermann

Photos: Fotolia, Industry, Thomas Pletsch,
Birgit Zimmermann. All photos
protected by copyright.

product range subject to change, no liability
accepted for mistakes or printing errors. Right
reserved to make product changes. Copying
of any kind, even of extracts, requires written
permission.

Delivery and ordering conditions

I. Decisive conditions

1. The legal relationships for all supplies and services provided to companies (customers) by Dönges GmbH & Co. KG (supplier) are based upon these conditions and any other agreements that have been made.
2. Changes and additions must be made in writing. Other general business conditions shall not apply, even if they have not been expressly objected to in isolated cases. These delivery and ordering conditions also apply to all future supplies and services provided to the customer by the supplier, even if they have not been expressly re-agreed. They only apply to companies in the sense of § 14 of the BGB. The obligations in § 312e para. 1 no. 1 to 3 of the BGB are excluded.

II. Ordering

1. Orders and acceptance pertaining to delivery agreements, general agreements and requests for delivery and changes and additions thereto must be made in writing. Requests for delivery can also be submitted by means of remote data transmission.
2. The supplier's products are subject to change and non-binding. Procurement agreements, quality guarantees and service life guarantees must be made in writing.
3. Unless otherwise agreed, delivery must be made uninsured at the customer's cost and risk to the place of acceptance or use that has been or will be specified by the customer. The risk is transferred to the customer when the goods are handed over to the person who is responsible for transport. This also applies if the supplier has a debt to be discharged at the customer's domicile.
4. In the event of an obligation to bring or send, the supplier is entitled to determine the means of transport and the route. Differing agreements must be made in writing.

III. Prices and payments

1. All prices specified by the supplier exclude VAT at the applicable rate. The prices do not include the cost of packaging, delivery and insurance, which must be paid for separately by the customer unless the supplier expressly confirms in writing that the cost thereof will be covered.
2. Unless otherwise expressly agreed, payment will be made within 10 calendar days of the date of the invoice with 2% discount, or net within 30 days of receipt of the invoice. This also applies to the receipt of early deliveries. The supplier is entitled to demand concurrent delivery at any time, without giving reasons.
3. Payment will be made by bank transfer or cheque. Cheques will only be accepted as conditional payment.
4. If the delivery is defective, the customer is entitled to retain a proportional amount of the payment until the delivery has been properly fulfilled.
5. The supplier is entitled to transfer his claims against the customer or have them collected by third parties, without obtaining written agreement from the customer beforehand.
6. The customer is only entitled to offset such counter-claims that have been legally ascertained, concern a counter-demand that is to be adjudicated upon, are undisputed by the supplier or concerning which the supplier has expressly agreed to the offsetting in writing. The customer also only has the right to retain payment in the cases mentioned in clause 1.
7. No restrictions are placed on the supplier's payment retention and offsetting rights. The legal regulations apply.

IV. Confidentiality

1. The parties to the contract are obliged to treat all non-public commercial and technical details that they learn about via the business relationship as confidential. Drawings, models, templates, samples and similar objects must not be handed to unauthorised third parties or made otherwise available. The copying of such objects is only permitted within the scope of company requirements and copyright regulations. These obligations continue beyond the end of the supply relationship. Sub-suppliers shall be obligated by the supplier accordingly.
2. The parties to the contract may only use the business relationship for the purpose of advertising if written approval is obtained beforehand.

V. Delivery dates and periods, delivery modalities

1. Agreed deadlines and periods are only binding if they have been confirmed in writing by the supplier.
2. A confirmed delivery date is subject to the reservation that the supplier has obtained correct, complete and on-time delivery itself. If the supplier fails to deliver to the vendor, both parties are entitled to withdraw the contract. The supplier is not liable (section XI) in the case of clauses 1 and 2 only if the defective, delayed or omitted delivery from its own supplier is not the result of an infringement of obligations by the supplier.
2. Unless otherwise agreed in writing, on-time provision of the goods for dispatch (in the event of an obligation involving the dispatch of what is owed), for delivery (in the event of an obligation that the debtor has to perform at the creditor's address) or for collection (in the event of a debt to be collected at the debtor's address) and appropriate notification to the customer is decisive for adherence to the delivery date or delivery period.
3. Goods that are delivered early must be accepted by the customer. The right to return at the supplier's cost has not been agreed, and is subject to formal written agreement between the parties. If the customer stores the goods until the agreed delivery date, he must bear all of the costs that are incurred. Storage shall take place at the customer's risk.
4. Partial deliveries are permitted, provided that the customer is not unreasonably disadvantaged as a result.

VI. Late delivery

If late delivery occurs as a result of simple negligence, the customer's claim for compensation is limited to 5% of the order value. Provided that there are no special regulations in this section, section XI also applies with regard to liability for late delivery compensation.

VII. Force majeure

Acts of God, industrial disputes, riots, official actions and other unforeseen, unavoidable and serious events free the contracted parties for the duration of the problem and for the scope of the effect thereof on the work obligations. This also applies if these events occur at a point in time when the affected party to the contract is behind schedule. The parties to the contract are obliged to provide the required information without delay (within reason) and adapt their obligations to the changed circumstances in good faith.

VIII. Quality and documentation

Changes to the subject of the delivery do not require prior written permission from the customer if they have been requested by the customer or are appropriately relevant to the state of technology.

IX. Deficiencies, deficiency notifications and notification deadlines

1. § 377 HGB applies unrestrictedly between the parties with the resulting obligations for the customer's received goods checking. The supplier's outgoing goods checking is not a substitute for the customer's received goods checking, which the customer is obliged to carry out as per § 377 of the HGB.
2. The customer is obliged to provide notification of deficiencies relating to dispatch and discrepancies in the accompanying papers and all other deficiencies within two working days of receipt, provided that they become evident. The notification deadline for deficiencies that become evident during a proper examination is seven days after receipt, and seven days after discovery for concealed deficiencies.
3. The goods provided by the supplier are free of material defects if their characteristics are within the generally recognised and production-related tolerances.

X. Warranty rights

1. If the goods prove to be defective, the customer can demand the following (Section XI remains unaffected) if the relevant legal prerequisites exist and nothing else has been agreed:
 - a) The customer's warranty rights are restricted to supplementary performance. If the supplementary performance is not provided, the customer has the option of reducing the payment or withdrawing from the contract.
 - b) The choice between defect remedying or subsequent delivery will be made at the supplier's discretion. Defect remedying and subsequent delivery shall always take place on a goodwill basis and without recognition of a legal obligation.
 - c) If the customer exercises his right to choose, his claim for supplementary performance will be restricted to the selected type of supplementary performance until this variant proves to be impossible or the supplier refuses to carry out the selected type of supplementary performance. This does not affect the purchaser's right to assert a price reduction, withdrawal or compensation under the legal prerequisites as a result of failure to provide supplementary performance.
 - d) In the event of an infringement of obligations beyond the scope of the delivery of defective goods (e.g. an explanation, advice or examination obligation), the customer can demand compensation for the resulting consequential damage and the consequential damage that the customer has to pay to his own customer in accordance with section XI. Consequential damage is the damage that the customer has suffered to other legally protected interests than the goods themselves as a result of delivery of defective goods.
 - e) If the customer asserts compensation claims due to a defect, the regulations in section XI apply as well as this section.
2. The regulations concerning contractor recourse as per § 478 BGB are unaffected by the regulation in section 1 above.
3. The customer must make the parts that are to be replaced by the supplier available to the supplier without delay upon request, and at the supplier's cost.

4. Deficiency claims do not exist if the fault is attributable to failure to follow operating, maintenance or installation instructions, unsuitable or improper use, defective or negligent handling and natural wear, or intervention in the subject of supply by the customer or third parties.

5. If the customer asserts a claim for supplementary performance or exercises his entitlement to withdraw from the purchase agreement or reduce the purchase price due to a material defect, his claim for supplementary performance or repayment of the purchase price shall come under the statute of limitations.

- in four years, if the subject of the purchase exists in a building or an object that has been used for a building in accordance with its normal purpose of use and has caused the deficiency,
- otherwise after 12 months.

6. Clause 5 does not affect the statute of limitations of repayment claims in accordance with § 479 BGB. The legal regulations also apply to the statute of limitations, particularly regarding the start of the statute of limitations. This regulation in section X number 1b clause 2 remains unaffected.

7. If defective deliveries are made, this section X shall not affect customer claims under the terms of the product liability act, for non-permitted action or for carrying out business without an order. Quality and service life guarantees must be formally identified as such individually in writing.

XI. Liability

1. A prerequisite for the supplier obligation to pay compensation is that the supplier was to blame, or the blame for the damage that was caused is attributable to the supplier. The statute of limitations regulation in § 438 of the BGB (German Civil Code) also applies to compensation for damage suffered by the customer to other legally protected customer interests (e.g. property, persons etc.) belonging to the customer or third parties as a result of the deficiency, provided that § 438 of the BGB basically applies to the agreement. Section X.5 and X.6 clauses 1 and 2 (particularly duration of statute of limitations, beginning of statute of limitations etc) apply accordingly. The following clauses in this section must be observed regarding the reason for and the scope of liability.

2. The supplier is unrestrictedly liable for non-accidental injuries caused by the supplier. The supplier is also liable for compensation only in the event of deliberate or grossly negligent obligation violations by himself, his legal representatives or by persons who the supplier uses to fulfil his obligations. In the event of slightly negligent violation of obligations by the above-mentioned persons, the supplier is only liable for compensation if the infringement represents a violation of important contractual obligations. An important contractual obligation in the above-mentioned sense is an obligation that makes proper fulfilment of the agreement possible at all, and adherence to which the contractual partner can and does regularly rely on. In the event of slight negligence, the level of liability is restricted to the damage that is typical for this type of agreement.

3. If claims are made from the customer due to non-negotiable liability to third parties regardless of blame, the supplier is only liable to the customer to the extent of his liability to the customer in accordance with legal regulations or the terms of these conditions of sale.

The principles of § 254 of the BGB apply accordingly for compensation paid between the customer and the supplier. This also applies in the event of direct supplier claims.

4. The obligation to pay compensation does not apply if the customer has effectively restricted his liability to his customers. In this case the customer will also strive to agree liability restrictions in favour of the supplier to a legally permissible extent.

5. Claims made by the customer are excluded if the damage is attributable to the violation of operating, maintenance or installation instructions, unsuitable or improper use, defective or negligent actions, natural wear or defective repairs by the customer.

6. The customer will inform and consult the supplier without delay if he wishes to make use of the above-mentioned regulations. He must give the supplier the opportunity to investigate the damage case. The parties to the contract will agree on the actions to be taken, particularly in the event of compensation negotiations.

7. The liability restrictions and exclusions in accordance with clauses 1 to 6 of this section apply to the same extent in favour of the supplier's legal representatives, management and non-management employees, other parties involved in fulfilment and subcontractors.

XII. Protection rights

1. The supplier is liable for claims resulting from contractual use of the subject of the supply for violation of protection rights and patent registrations (patents), only within the scope of the legal regulations, taking the liability regulations in these conditions of sale into consideration (section XI).

2. In particular, the supplier does not release the customer and his customers from all claims resulting from the use of such protection rights if he is not liable as per clause 1.

3. In particular, the supplier is not liable provided that the subjects of the supply have been manufactured in accordance with customer drawings, models or equivalent other descriptions or specifications that have been handed over by the customer, and does not know that protection rights have been violated or does not have to know in connection with the products that he has developed.

4. The parties to the contract are obliged to notify each other without delay about violation risks and alleged violations that become known, and give each other the opportunity to amicably counteract the violation(s) accordingly.

5. If requested to do so by the supplier, the customer will provide notification of the use of public and non-public supplier patents, licensed patents and patent registrations for the subject of the delivery.

6. If the supplier is liable as per clauses 1 to 5 and nothing else has been expressly agreed in writing, the supplier is only liable for patent violations that occur in Germany.

XIII. Contractual penalties, lump sum compensation payments

Irrespective of the type of damage (deficiency claims, compensation instead of or in addition to the services, product liability etc.) the customer must specifically bill for the damages that he has suffered. No flat rate has been agreed for compensation claims, and no contractual penalties have been agreed between the parties. Flat compensation rates and contractual penalties can only be agreed in individual contracts and must be made in writing.

XIV. Title retention

1. The supplier reserves ownership of all goods that he supplies until full payment has been received; all deliveries are considered to be one continuous delivery in this respect. For open accounts, retained ownership is considered to be a safeguard for a balance request.

2. If the customer combines the goods with other objects to create a uniform object and the other object is considered to be the main product, the customer is obliged to transfer proportional co-ownership to the supplier if the main object belongs to him. If the supplied goods are sold on by the customer, he thereupon transfers claims against his own customers resulting from the sale to the supplier together with all secondary rights until all supplier claims have been settled in full.

3. For well-justified reasons, the customer is obliged to provide notification of transfer to third party purchasers if requested to do so by the supplier, and provide the supplier with the required information and documents that are required to assert his rights.

4. The supplier will release the securities that he has retained if the total value thereof exceeds the claims that are being protected by more than 10%.

XV. Take-back of goods

1. Goods will only be taken back if prior agreement is obtained from the supplier. The returned goods must be in a re-sellable condition and comply with the latest state of technology. The returned goods credit note will be drawn up at the original prices, minus a 10% processing fee. Costs incurred by third parties will be billed for separately.

XVI. General conditions

1. If one of the parties ceases to making payments, insolvency proceedings are started or private conciliation proceedings are applied for, the other party is entitled to withdraw from the contract for the non-fulfilled part.

2. If a term of these conditions and any other agreements that have been made is ineffective or becomes ineffective, the validity of the remainder of the contract is not affected. The parties to the contract are obliged to replace the ineffective term with a regulation that comes as close as possible to providing the same financial result.

3. The laws of the Federal republic of Germany exclusively apply. The use of the United Nations convention of 11.04.1980 concerning contracts involving international sales is excluded.

4. The place of fulfilment will be in accordance with legal regulations. Differing agreements can only be made in individual contracts and must be made in writing.

5. The place of jurisdiction for all legal proceedings is the business headquarters of the supplier, providing that the customer is a merchant, juristic person in public law or separate asset under public law. The supplier is also entitled to claim from the customer at his general place of jurisdiction if he wishes to do so.