

**MAGIRUS** FIRE-FIGHTING VEHICLES AND TANK PUMPERS



**SERVING HEROES. SINCE 1864.**

 **MAGIRUS**



# FIRE-FIGHTERS DON'T SIMPLY DO A JOB. THEY FOLLOW A CALLING.

Our job is to support them with first-class equipment.

Every day, fire-fighters and disaster relief workers around the world do their best to save lives, defy the forces of nature and rescue people from difficult situations. But again and again, they outdo themselves to become the true heroes of our day. These people don't simply do a job, but follow their calling. Just like us at Magirus.

Our passion is to build the best fire-fighting equipment in the world, the best turntable ladders, the best fire-fighting vehicles, rescue vehicles and the best logistics vehicles, special vehicles, airport fire-fighting vehicles and components. We are utterly convinced that the best fire-fighting equipment is built by fire-fighters.

Only they know what their comrades need in an emergency, what makes their work easier and what gives them the greatest possible safety. Many of our employees are also active in fire-fighting and disaster response teams themselves and work closely with their customers, who are at the same time also their comrades.

In this manner, we have developed and manufactured innovative solutions for 150 years – from major developments down to the small improvements that continually make a difference and make life easier for everyone involved in a mission. Our motto is likewise our claim. Rooted in history, oriented towards the future.

Magirus. Serving Heroes. Since 1864.





*"In an emergency there's no second chance. So everything has to be right from the start"*





# FIRE-FIGHTING VEHICLES FOR EVERY NEED. AND EVERY CHALLENGE.

From medium pumpers meeting national and international standards all the way to highly individual large tank pumpers and special fire-fighting vehicles, we build them.

Regardless of what country in the world, whether in the north or the tropics, in a big city, in the countryside or in a forested area, in an industrial complex, whether a special application, according to a standard or national specification: Magirus builds fire-fighting vehicles that meet your very specific requirements.

A wide range of cab variants and highly flexible superstructure concepts lets us configure and realise the optimum solution for every suitable chassis at every tonnage. Pump technologies and proportioning systems from our own in-house range complete the spectrum.





www

MAGIRUS

IVECO

120E80

www.MagirusGroup.com



# MAXIMUM FLEXIBILITY AND STORAGE SPACE WITH AN INTERNAL TANK.

The optimum superstructure concept when the focus is on team and equipment – with plenty of storage space and flexibility for tactically oriented loading and individual demands.

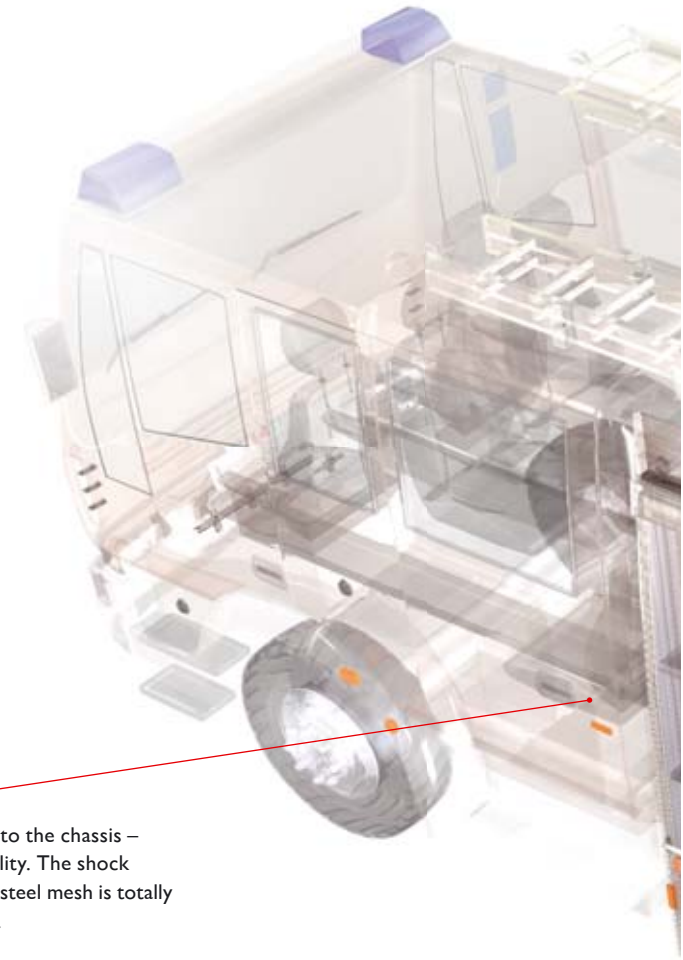

## ELASTIC MOUNTING

✓ The superstructure is not directly connected to the chassis – for safer handling and greater torsional flexibility. The shock absorber with its specially-developed stainless steel mesh is totally unaffected by dirt, corrosion, salt or UV light.

## HIGH-VOLUME SUPERSTRUCTURES

✓ The concept offers plenty of storage space alongside the tanks. Lowered equipment lockers (some optional) between and behind the axles increase the available space even more.



## VARIABLE MODULAR FRAME

✓ The frame profile is specially designed to exactly fit the application. Variable screw construction and adjustable width and length allow flexible modification of the frame to accommodate the axle load situation of various chassis as well as different fire-fighting water tank sizes.

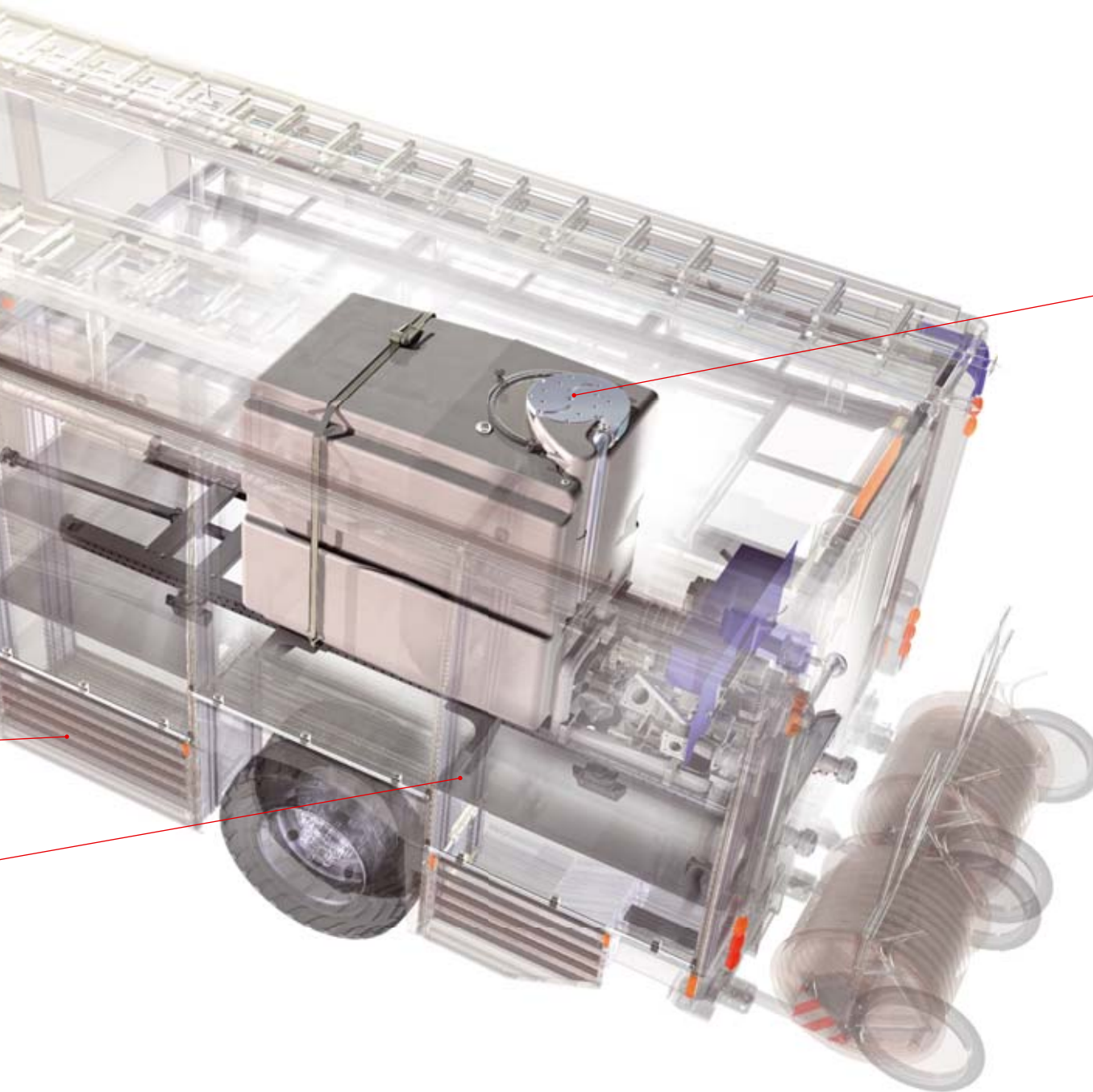

#### MODULAR TANK SYSTEM

/ The modular system is flexible: both in terms of water and foam volumes and positioning of the tanks in the vehicle. Three different tank widths are possible. Narrow tanks leave a greater depth for equipment lockers. Different tank widths and modular foam tank combinations allow for custom-tailored extinguishing agent solutions.







/ Compact fire-fighting vehicle 4x2

/ Compact fire-fighting vehicle 4x4 single tyres



/ Compact fire-fighting vehicle 4x2

/ Compact fire fighting vehicle 4x4 single tyres







# AS VERSATILE AS THE JOB: MAGIRUS COMPACT CLASS FIRE-FIGHTING VEHICLES.

This outstanding vehicle concept is ready to meet the many big challenges that life presents to small and medium-sized fire brigades in the city and in the country.

## Features

- / Comprehensive gear for fire-fighting and technical assistance
- / Rear pump 2,000 l/min at 10 bar + 250 l/min at 40 bar
- / GFK water tank 2,000 l
- / Crew module: All-steel or aluminium technology
- / Seats: 1+8

## Special features and advantages

- / Spacious AluFire 3 superstructure with variable equipment room system and three lateral roller shutters
- / Lowered between the axles and behind the axle for more ergonomic storage of heavy equipment
- / Optimal water tank arrangement for well-balanced weight distribution without overloading the rear axle
- / Optimally ergonomic removal heights
- / Pump easily accessible from the rear for control and maintenance
- / Large space reserves with room for individual additional gear and personal equipment
- / Continuous ambient illumination for balanced illumination of the mission site

## Options

- / GFK water tank: 1,000 l / 1,200 l
- / Foam tank capacity: 120 l / 150 l / 200 l
- / Pressure foam proportioning system: CaddiSys (with electric drive) or FireDos (with hydraulic drive); 0.1 – 6% proportioning
- / Crew cab 1+5
- / Loading variants
- / Light mast: pneumatic, floodlights in halogen, xenon or LED technology
- / Superstructure lighting: LED technology
- / Warning system: integrated MAGIRUS M-Flash LED technology
- / Traffic warning system: LED technology
- / Alternative warning and signalling systems
- / Pull-out hygiene board
- / Breathing apparatus units in cab: 4
- / Wide range of additional equipment available
- / Superstructure can be mounted on all conventional 4x2 and 4x4 chassis in the 9 to 14 ton class
- / Pump in bronze version

This vehicle type can also be realized according to the national standards and regulations of many countries.







/ Premium fire-fighting vehicle 4x4 single tyres

/ Premium fire-fighting vehicle 4x4 twin tyres



/ Premium fire-fighting vehicle 4x2

/ Premium fire-fighting vehicle 4x4 twin tyres







# PREMIUM CLASS VEHICLES: THE MAGIRUS ALL-ROUNDERS FOR EVERY MISSION.

The strong partner for fire brigades with a broad mission profile –  
As individual and special as your needs.

## Features

- / Comprehensive gear for fire-fighting and technical assistance
- / Crew cabs: all-steel or aluminium technology
- / Seating variants: 1+5, 1+8
- / Rear pump: 3,000 l/min at 10 bar + 450 l/min at 40 bar
- / GFK water tank: 3,000 l
- / Light mast: pneumatic, floodlights in halogen, xenon or LED technology

## Special features and advantages

- / Spacious AluFire 3 superstructure with variable equipment room system and three lateral roller shutters
- / Lowered between the axles and behind the axle for more ergonomic storage of heavy equipment
- / Optimal water tank arrangement for well-balanced weight distribution without overloading the rear axle
- / Optimally ergonomic removal heights
- / Pump easily accessible from the rear for control and maintenance
- / Large space reserves with room for individual additional gear and personal equipment
- / Continuous ambient illumination for balanced illumination of the mission site

## Options

- / GFK water tank: 2,000 l / 2,400 l / 4,000 l
- / Foam tank capacity: 150 l / 200 l / 400 l
- / Pressure foam proportioning system: CaddiSys (with electric drive) or FireDos (with hydraulic drive); 0.1 – 6% proportioning
- / Load variants
- / Ladder on roof with unloading device
- / Breathing apparatus units in cab: 4 units / 5 units / 7 units
- / Superstructure lighting: LED technology
- / Warning system: integrated MAGIRUS M-Flash LED technology
- / Alternative warning and signalling systems
- / Pull-out hygiene board
- / Cab integrated in the bodywork
- / Wide range of additional equipment available
- / Superstructure can be mounted on all conventional 4x2 and 4x4 chassis in the 14 to 18 ton class
- / Pump in bronze version

This vehicle type can also be realized according to the national standards and regulations of many countries.







Fire-fighting vehicles for civil protection



Optimum mission tactics: rear hose storage



Lowerable fire pump storage for ergonomic removal



Special equipment for long distance waterway





# FOR EVERYDAY FIRE-FIGHTING AND CIVIL PROTECTION.

Everything response teams need: the necessary civil defence equipment and plenty of reserves for gear according to individual needs.

## Features

- / Comprehensive gear for fire-fighting and pumping water over long distances
- / Additional load of hoses and valves for pumping water over long distances
- / Crew module: all-steel or aluminium technology
- / Seats: 1+8
- / Breathing apparatus units in cab: 2 units
- / Rear pump: 2,000 l / min at 10 bar
- / Fire pump MAGIRUS FIRE; 1,000 l / 10 bar
- / GFK water tank: 1,000 l
- / Mission site illumination: 2 x 1,000 W

## Options

- / GFK water tank: 1,300 l / 1,600 l
- / Light mast: pneumatic, floodlights in halogen, xenon or LED technology
- / Superstructure lighting: LED technology
- / Warning system: integrated MAGIRUS M-Flash LED technology
- / Rear warning system
- / Alternative warning and signalling systems
- / Pull-out hygiene board
- / Wide range of additional equipment available
- / Superstructure can be mounted on all conventional 4x4 chassis in the 14 to 18 ton class

## Special features and advantages

- / Spacious AluFire 3 superstructure with variable equipment room system and three lateral roller shutters
- / Lowered between the axles and behind the axle for more ergonomic storage of heavy equipment
- / Fire pump storage, pneumatic lowering
- / Optimally ergonomic removal heights
- / Rear hose storage unit for approximately 360 m B-hoses; Double standing stations at rear for monitoring hose storage while driving and for signalling systems
- / Additional features for civil protection missions
- / Large space reserves with room for individual additional gear and personal equipment
- / Spacious overhead boxes for additional storage space



/ Double standing stations at rear for monitoring hose storage while driving

This vehicle type can also be realized according to the national standards and regulations of many countries.





/ Multi-purpose vehicle with short wheel base



/ Multi-Purpose vehicle with long wheel base



/ Mult-Purpose Vehicle with crew compartment 1+8



/ Mult-Purpose Vehicle with crew compartment 1+5



/ Mult-Purpose Vehicle with extra-long wheel base





# THE MULTI-PURPOSE VEHICLE FOR ALL KIND OF MISSIONS.

This extremely versatile tank pumper with internal tank and an enormous amount of storage space is perfect for fire-fighting in rough terrain.

## Features

- / Single-tyre all-wheel chassis with short wheel base optimally suited for fire-fighting without paved roads and in rugged terrain
- / Crew cabin: 1 +2
- / Rear pump: 3,000 l/min at 10 bar + 400 l/min at 40 bar
- / GFK water tank: 3,000 l

## Special features and advantages

- / Spacious AluFire 3 superstructure with variable equipment room system and two lateral roller shutters
- / Lowered between the axles for more ergonomic storage of heavy equipment
- / Optimal water tank arrangement for well-balanced weight distribution without overloading the rear axle
- / Optimally ergonomic removal heights
- / Pump easily accessible from the rear for control and maintenance
- / Large space reserves with room for individual additional gear and personal equipment
- / Also available as a long wheel base model featuring more storage space for gear

## Options

- / GFK water tank: 4,000 l
- / Foam tank capacity: 120 – 300 l
- / Rear pump: 3,000 l min at 10 bar
- / Pressure foam proportioning system: CaddiSys (with electric drive) or FireDos (with hydraulic drive)
- / Roof monitor: water / foam
- / Ground sweep and self protection nozzles on both axles
- / Crew compartments in various sizes (note national specifications)
- / Light mast: pneumatic, floodlights in halogen, xenon or LED technology
- / Superstructure lighting: LED technology
- / Warning system: integrated MAGIRUS M-Flash LED technology
- / Traffic warning system: LED technology
- / Alternative warning and signalling systems
- / Pull-out hygiene board
- / Additional gear: forest fire-fighting
- / Outfitting of empty spaces according to customer's requirements
- / Superstructure can be mounted on all conventional 4x4 chassis in the 14 to 18 ton class
- / Rescue equipment
- / Hazmat equipment



/ Mult-Purpose Vehicle with crew compartment and tank with 4,000 litres

This vehicle type can also be realised according to the national standards and regulations of many countries.





Customized Tank pumper with long wheel base and crew compartment 1+8



Customized Tank pumper with short wheel base and crew compartment 1+5



Customized Tank pumper with crew compartment 1+8



Customized Tank pumper with long wheel base



Front-mounted winch for technical assistance and self-removal





# CUSTOMIZED SOLUTIONS WITH UNLIMITED EXTINGUISHING POWER.

With its large-dimension tank this pumper meets all your needs for additional gear or a roomy crew compartment.

### Features

- / Optimally suited for fire-fighting without paved roads and in rugged terrain with all-wheel chassis
- / High extinguishing agent volumes water / foam
- / Rear pump: 4,000 l/min
- / GFK water tank: 4,000 l

### Special features and advantages

- / Spacious AluFire 3 superstructure with variable equipment room system
- / Lowered between the axles and behind the axle for more ergonomic storage of heavy equipment
- / Optimal water tank arrangement for well-balanced weight distribution without overloading the rear axle
- / Optimally ergonomic removal heights
- / Pump easily accessible from the rear for control and maintenance
- / Large space reserves with room for individual additional gear and personal equipment

### Options

- / Pressure foam proportioning system CaddiSys (with electric drive) or FireDos (with hydraulic drive)
- / Roof monitor water / foam
- / Ground sweep and self protection nozzles on both axles
- / Pressure outlet for fire-fighting water at the front of the vehicle
- / Choice of crew or group cab 1+5 / 1+8 (note national specifications)
- / Light mast: pneumatic, floodlights in halogen, xenon or LED technology
- / Superstructure lighting: LED technology
- / Warning system: integrated MAGIRUS M-Flash LED technology
- / Traffic warning system: LED technology
- / Alternative warning and signalling systems
- / Pull-out hygiene board
- / Winches for technical assistance and self-removal
- / Protective and roll bars for self-protection
- / Additional gear: forest fire-fighting
- / Outfitting of empty spaces according to customer's requirements
- / Wide range of additional equipment available
- / Superstructure can be mounted on all conventional 4x4 chassis in the 16 to 19 ton class
- / GFK water tank: 5,000 l
- / Foam tank: 500 l
- / Pump in bronze version



/ Front pressure outlet or roof monitor for individual emission of extinguishing agent



This vehicle type can also be realised according to the national standards and regulations of many countries.



# POWERFUL EXTINGUISHING SPECIALIST WITH EXTERNAL TANK.

The optimum structural concept where use of large quantities of different extinguishing agents is concerned. The additional equipment carried can be selected flexibly, whether for a specific kind of fire-fighting or for universal use.

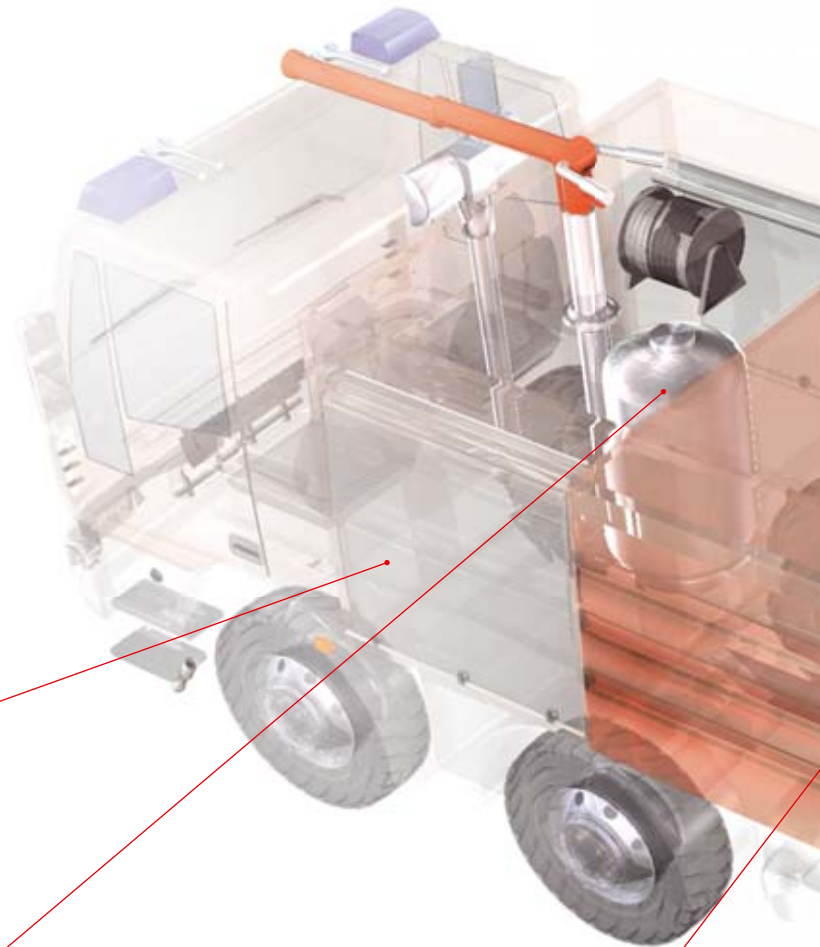

## EQUIPMENT SPACES

For fire fighting gear and equipment in front of and behind the extinguishing medium tanks. Lowered equipment lockers are available as an optional extra.

## SPECIAL EXTINGUISHING SYSTEMS

Powder, CO<sub>2</sub>, gels etc. are possible depending on the mission situation. We'll formulate the combination of extinguishing agents to meet individual customer requirements.



## LARGE TANKS

Large tanks transverse to the rear axle(s) make it possible to realise up to 18,000 l of extinguishing agent. Individual and specific solutions can be combined with special extinguishing systems such as foam, powder or CO<sub>2</sub> for example as are used at plant fire brigades. MAGIRUS pump with user-friendly HMI control



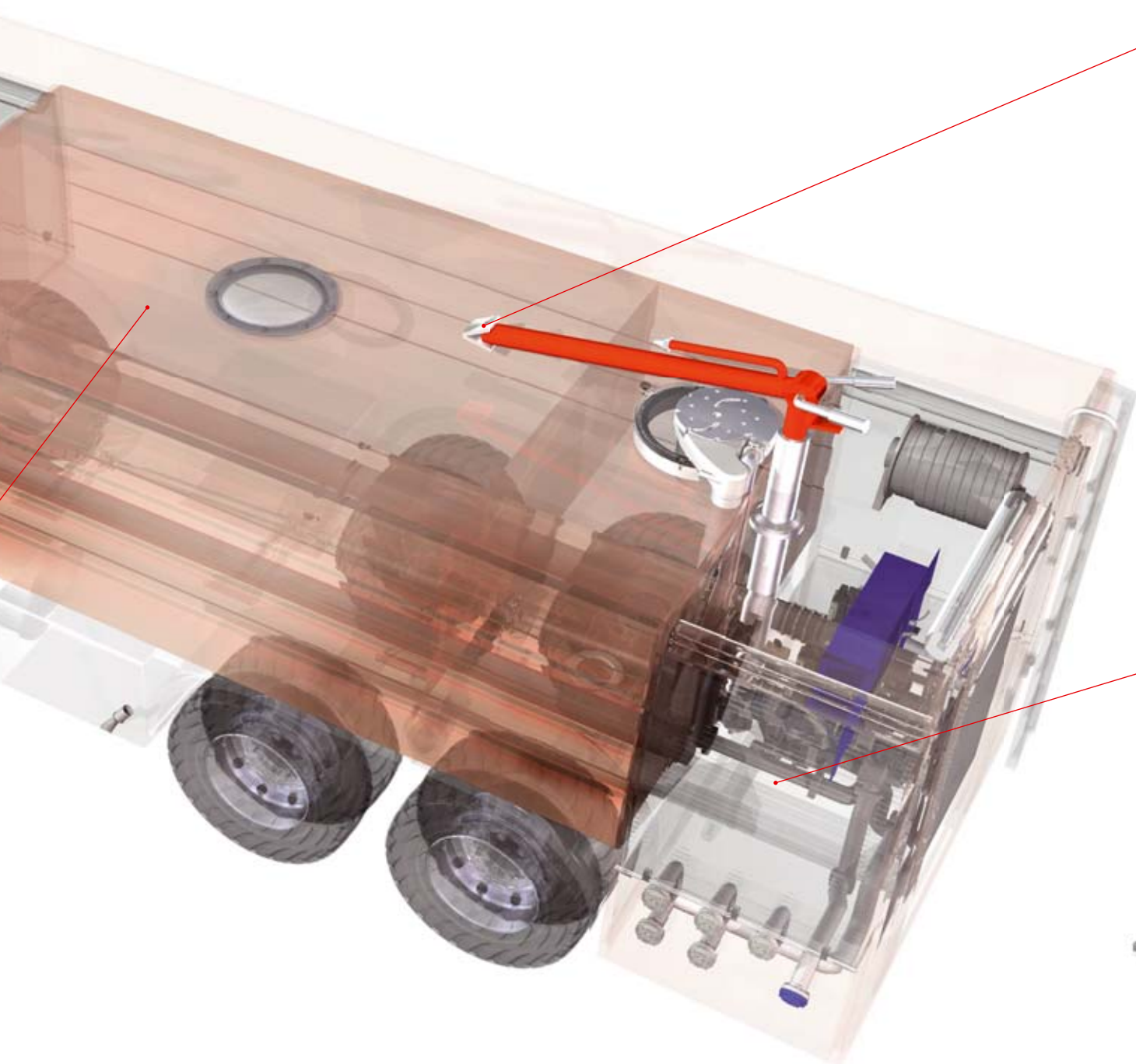

#### HIGH-CAPACITY MONITORS

- With spray performance of from 400 to 6,000 l/min mean precisely targeted extinguishing power. They can be mounted on the driver's cab, the superstructure roof or the bumper. The monitors can be controlled flexibly. A choice is available between manual operation and remote control operation by radio or cable.
- A variety of foam pipes are available, including self-priming pipes, as well as combined monitors with multiple pipes for using water, foam and powder.



#### FOAM PROPORTIONING SYSTEMS

- MAGIRUS CaddiSYS (with electric drive); optionally also available with compressed air support CaddiCAFS
- MAGIRUS FireDos® – (with hydraulic drive)





# NOT STANDARD: CUSTOM-FIT THROUGH AND THROUGH. PRECISION WORK ON A LARGE SCALE.

Standard products are not of much use when nothing is defined by standards, when everything has been custom-made and individually adapted. We have the expertise necessary to get highly specialized unique vehicles on the road, regardless of how many are needed.

Tank pumpers for the most highly specialized mission profiles in industry or in municipal use are always custom-tailored solutions designed to exactly fit the customer's requirements.

Strongly motorised 2, 3 or 4 axle chassis, tonnages up to 40 t, various cab sizes, all types and quantities of extinguishing agents, special proportioning systems, high-performance pumps, monitors, telescopic extinguishing booms, light systems, winches and special gear combine to make unique special fire-fighting vehicles for industry, refineries and chemical plants. We have the engineering expertise and the experience needed to combine all of these factors to form a 100 % deployment-ready whole.



/ Telescopic extinguishing booms enhance the vehicle's tactical abilities for fire-fighting e.g. in industrial plants.





/ Tank pumpers are custom-tailored to fit the mission profile in question – e.g. with various crew compartments, tank sizes, proportioning systems and special extinguishing agents.



# BUILD ON THE ORIGINAL: ALUFIRE 3.

With the third generation of AluFire 3 you'll benefit from all the advantages of a system which has been proven a thousand times over.

## Features

- / AluFire 3 is built with modular hardware and software. It constitutes a uniform system, across all tonnages and vehicle types, from the TSF to the tank pumper, from 4 tons to 40 tons.
- / Materials and structures specially developed for MAGIRUS are designed to withstand long-term heavy duty operation.
- / The integrated electronics are intentionally used to enhance, support and secure functionalities. One unique feature is the MAGIRUS CAN-Bus control with redundant data lines for all main functions (e.g. pump functions) and intelligent splitter modules.
- / All functions have a standard user interface. The low need for cabling increases the operational safety of the overall system and makes it easier to integrate options.



## Your advantages

- / Maximum flexibility for the realisation of optimum solutions for a wide variety of requirements and specifications
- / High performance under stress, robust and long service life
- / Highest possible reliability due to system-specific operational safety and excellent error management
- / Greatest service operability and cost-efficiency
- / Ease of use, simple operation even for inexperienced response teams and under the most difficult mission conditions

## SPACE-SAVING ROLLER SHUTTER SYSTEM

- / Narrow roller shutter tracks increase the amount of useable space and help make room for additional gear. Installation in the superstructure leaves more room on the roof for high-volume storage boxes.

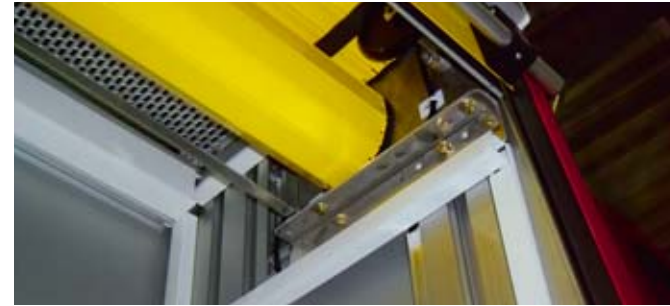

## LOAD-CARRYING SOLUTION

- / Highly stable sandwich floor panels are extremely strong. Countersunk screws prevent injuries and damage to equipment.





#### FIRECAN-COMPATIBLE

/ The standardised interface between superstructure and components supports the exchange of components from different vendors (Plug and Play) as well as central diagnostics of the integrated components.

#### EFFICIENT

/ An energy management system permanently monitors the system to ensure that unneeded components consuming electrical power are switched off and guarantees that the vehicle's energy consumption stays low.

#### SEE AND BE SEEN

/ All lighting in the interior and exterior areas is available using the latest LED technology – for the greatest possible safety and minimal energy consumption.

#### FLEXIBLE IN THREE DIMENSIONS

/ Surrounded 360° with aluminium carrier bands for full loading flexibility: uninterrupted floor to roof loading is possible. Panel-shelves can also be inserted without the need to remove any components.

#### ROBUST. LIGHTWEIGHT. UNCOMPLICATED.

/ The anodized aluminium profiles are resistant and have an extremely long service life. Fewer components on the whole means reduced weight and simplified maintenance and repairs.

In combination with a maintenance contract we guarantee against rust-through for 12 years.





# EVERY MISSION DEMANDS THE HIGHEST PERFORMANCE – DOWN TO THE SMALLEST DETAIL.

Helping people in need is always the toughest of assignments.

That's why we mind every detail when ensuring your vehicle gives you the best support possible.

Your vehicle can't bear the enormous stress you endure on each mission for you. But it can give you perfect "backup", keeping you safe and saving your head and back for the actual tasks involved. We mean head and back in the literal sense: On the one hand simple and intuitive operating concepts let you concentrate on the mission instead of on the technology. And on the other hand clever ergonomic design details protect your physical strength, and thus your health as well.

## Details on optimum ergonomics and safety

Lowered equipment lockers in front of and behind the rear axle with standard integrated illuminated covers  
/ Good ergonomic removal heights for heavy equipment  
/ Safe climb-on

Self-locking tilted mounting ladders  
/ Ergonomic access to roof  
/ Secure control

Automatic ladder drop for ground removal of the ladder  
/ Secure, energy-saving handling

Non-slip step surfaces throughout  
/ Rapid accessibility of equipment items in the upper equipment locker  
/ Secure and easy removal even with large-sized tyres as with 4x4 variants

Stable rotating doors and compartments  
/ Ergonomic removal of equipment and devices

Heavy-duty extensions with rotating device fixtures /  
Pneumatic lowering of fire pumps  
/ Light, energy-saving removal of heavy equipment

Wide-scale continuous ambient illumination /  
Light mast for wide-scale illumination of the mission site  
/ Safe working conditions

Stable safety fixtures on mounts for mobile equipment containers  
/ Optimal protection against objects falling out

Anti-glare illumination of equipment lockers  
/ Fast, reliable recognition of equipment and devices in all lighting conditions

Rear warning system  
/ Securing mission site and response teams







/ The practical pull-out work surface can be used to hold equipment items and devices at an ergonomic height, e.g. when changing breathing apparatus bottles at the mission site.



/ With the hygiene board the team can wash hands, face and clothing items at the mission site. This eliminates the danger of contaminating the vehicle's interior.



/ As an alternative we can provide power generators which are run by a P.T.O. (Power Take-Off) from the chassis. The control field makes it ergonomic and safe to use.



# SAVE TIME, CREATE SPACE AND INCREASE SAFETY: THE MODULAR EQUIPMENT SYSTEM.

Fire brigades can choose individually from a wide variety of configuration options. We stow the gear so that you can work quickly and safely.

The AluFire 3 superstructure system creates a generous amount of space ideally utilised through many clever details that are clearly rooted in practice.

Of particular note are creative, individual solutions for stowage of equipment and fittings and many ideas which save time on the job and increase safety.



✓ The superstructure has no-slip hatches which are stable up to 250 kg. Safe equipment removal is even possible for vehicles with larger tyres.



✓ Heavy-duty pull-out shelves ensure optimum storage and energy-saving removal of mobile equipment units, e.g. ventilators or hydraulic rescue equipment.



✓ Full-size shelves with clearly arranged equipment and device units make working directly at the vehicle quick and efficient.





/ Accessible from two sides, the swing panel is easy to use and can be securely locked.



/ Quick attack compressed air allows rapid deployment e.g. of lifting bags, compressed air tools or inflatable boats.



/ Quick attack power enables fast implementation e.g. of lighting units or hydraulic equipment.



/ Optimum utilisation of space, including depth: The equipment lockers are positioned deep around the axles and offer a third level of storage for secondary materials.



/ All equipment necessary for technical initial response is mounted on a swing panel: at eye level, clearly visible, ergonomic, efficient.



/ LED light strips give the equipment lockers anti-glare illumination and ensure safe working conditions, both day and night.



# QUALITY ALL FROM ONE SINGLE SOURCE: MAGIRUS PUMPS AND PROPORTIONING SYSTEMS.

Constructing innovative superstructures is one thing, developing important components such as pumps and proportioning systems is another. We have mastered both. Everything comes from a single source and works together perfectly.

As a standard MAGIRUS offers you two-phase centrifugal fire-extinguishing pumps – including all the advantages.

## Features

- / Low RPM
- / Modular design
- / Compact dimensions, lightweight
- / Robust construction, optimized for hardness
- / Easy on the motor, low-noise, environmentally friendly
- / Series not sensitive to cavitation
- / MAGIRUS "Primatic" fully-automatic priming device
- / Suitable for bilge operations
- / High suction capacity
- / Not sensitive to wastewater

## Your advantages

- / Less wear and tear
- / Quiet, safe operations
- / Heavy duty, long service life
- / Highest possible extinguishing performance and effectiveness
- / Highest possible reliability and operational safety
- / Interchangeable component design makes maintenance and repairs easy
- / Cost savings

## Pump capacity

- / With internal tank 1,000 to 10,000 l / min at 10 bar
- / With external tank 2,000 to 10,000 l / min at 10 bar

## CaddiSYS: Reliable. Flexible. Simple.

The user-friendly MAGIRUS system features an electric drive and enables fast, efficient foam generation. Also available with compressed air support CaddiCAFS.

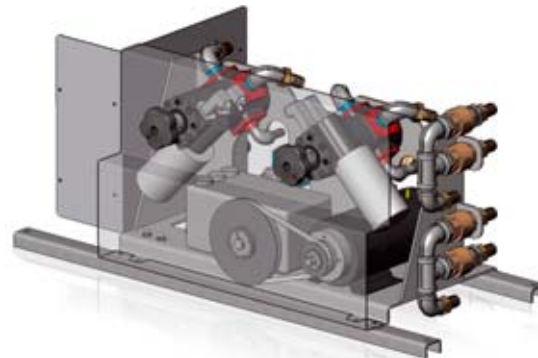

## Pump variants

- / Normal pressure pumps
- / Pumps with additional high-pressure level (pump capacity up to 250 / 400 l min at 40 bar)
- / All pumps are available in aluminium or bronze alloy

## FireDos®: Practical foam proportioning

The MAGIRUS FireDos® proportioning system features hydraulic drive and ensures consistent proportioning.





#### MAGIRUS PUMP HOUSING

- / The low pump control stand is ergonomic to operate.
- / The pump valve in the A suction intake can handle input pressure of up to 12 bar. This means higher hydrant pressures and pumping water over longer distances are no problem at all.
- / Design of pump input and output can be flexibly adapted to accommodate customer demands and national specifications.

#### MAGIRUS "PRIMATIC" SELF-PRIMING PUMP SYSTEM

- / MAGIRUS "Primatic" is the heart of our pumps. It is particularly safe to operate with low-wear properties. Its design is based on the membrane pump which is particularly insensitive to dirt. Activation and deactivation of the priming system is directly controlled by pump pressure – without the need for additional mechanical, hydraulic or electric tools.

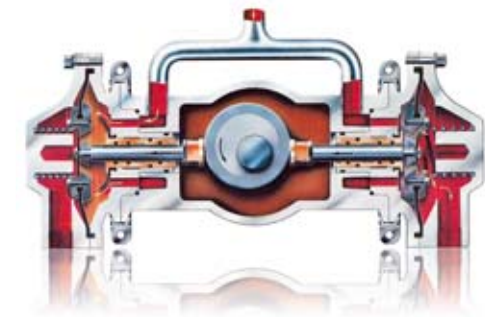
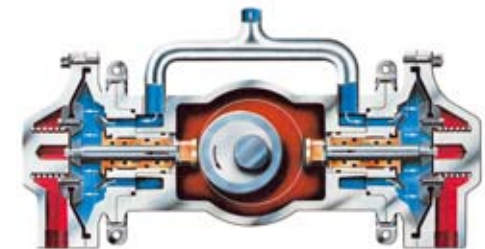



# LOGICAL, FAST AND INFORMATIVE: MAGIRUS HMI, THE PUMP CONTROL UNIT THAT SPEAKS YOUR LANGUAGE.

At the interface between man and machine communication has to be perfect. That's why we place primary emphasis on ease of use, simplicity and ease of understanding.

## Features

- / Modern, up-to-date control system
- / Logical, easy to understand combination of familiar classic pushbutton operation for main functions and a purely supportive display information
- / Simple menu structure with flat hierarchies – without complicated menu changes, without touchscreen
- / Buttons can be operated while wearing gloves
- / Display instruments, e.g. manometer, in familiar "analogue" look
- / Supports remote diagnostics for telematics systems
- / New - integrated operation of light masts
- / Control of all CAN-Bus networking in the superstructure and installed components via FIRECAN

## Your advantages

- / Quick and reliable operation, even without computer experience
- / Greatest possible ease of use and practical orientation
- / Easily readable information field for all superstructure functions – provides the operator with comprehensive information
- / Maximum efficiency and safety



/ The HMI operational element in the driver's cab is available as a luxury version (above) and as a simple basic version (below).

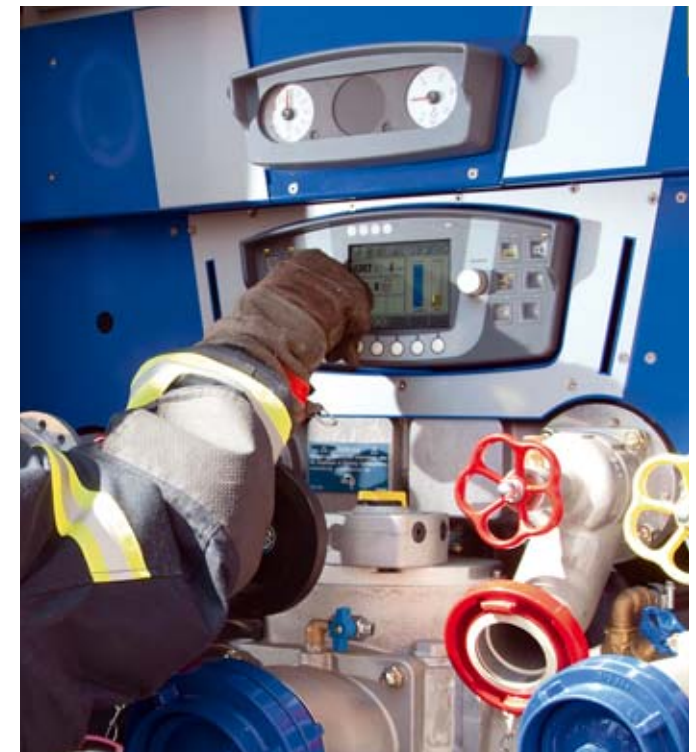

/ The rear HMI operational element is identical to the luxury version in the driver's cab. Operation while wearing gloves is not a problem. Modern – practically oriented – informative.



/ The version of the pump control stand in the rear of the vehicle is defined in accordance with your individual demands and specifications. The basic version has intentionally simple analogue control.



/ This variant features all the advantages of modern HMI control, but is not shielded. All components are visible and easily accessible.



/ Partial shielding of the pump space results in a modern, orderly appearance. The connections and hand valves are open and easily accessible.



/ As an alternative the pump space can be completely shielded – here we see the Austrian variant with high-pressure quick attack. Input and output lines are located on the side or below the pump space.

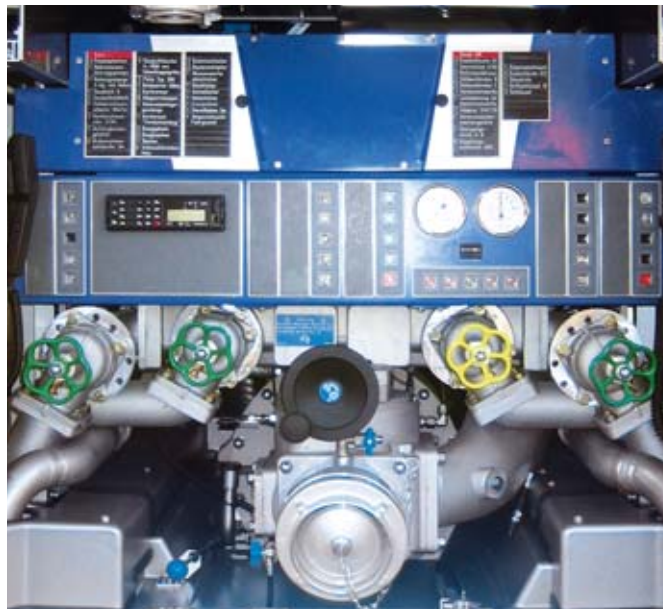

/ The MAGIRUS standard panel was developed according to the specifications of the German fire brigade association DFV and from various customers. The classic alternative.



## MAGIRUS MAKES THE PERFECT SERVICE VEHICLE OUT OF ANY CHASSIS.

Only the perfect combination of chassis and superstructure makes a fire engine usable in practice. We build our superstructures on the appropriate chassis of all manufacturers, tonnages, motorisations and types and coordinate the entire vehicle perfectly.

As a superstructure manufacturer we are open to any appropriate chassis, whether for the street or off-road, whether the application-specific development of the IVECO fire-fighting chassis or models from other manufacturers. No matter what you want in a vehicle: We coordinate the chassis and superstructure perfectly.



/ Tank pumper on Renault 4x2, with series cab



/ 2000 litre class fire-fighting vehicle on Mercedes 4x4, with MAGIRUS crew compartment in aluminium technology





/ 2000 litre class fire-fighting vehicle on MAN 4x4, with MAGIRUS crew compartment in aluminium technology



/ Specially configured fire-fighting vehicle on Scania 4x2, with series cab



/ Tank pumper 4000 on Volvo 4x4, with MAGIRUS crew compartment in aluminium technology



/ GTLF on Scania 4x4, with MAGIRUS crew compartment in aluminium technology



# WE GET YOU TO YOUR MISSION SAFELY. AND BRING YOU HOME SAFELY TOO.

Making comprehensive technical assistance and fire-fighting possible is as important to us as providing disaster responders with complete protection. This is particularly true of the trip to the mission.

How efficiently and safely an operation runs isn't decided when you arrive at the scene of action, but on your way there.

This is why the practical layout of the driver's cab and crew compartment is just as important for us as the way in which the equipment lockers are designed. We offer two different technologies for three application variants and various chassis types.



✓ The door of the aluminium cab can be opened to 90°. The step platform folds out entirely automatically at an ergonomic height. Completely illuminated, non-slip step surfaces and colour-highlighted handholds ensure maximum safety when boarding or exiting the vehicle. Suitable for Euro 6 exhaust gas technologies.



✓ Exploitation of the maximum vehicle width of 2.50 m for the crew compartment creates perfect space conditions inside the cab. The third window keeps the cab well lit and enables an excellent all-round view.

Aluminium technology



Features

- / Special aluminium cab for appropriate chassis from all manufacturers – connects to the rear wall of the truck driver's cab
- / Exploitation of the entire vehicle width of 2.50 m
- / Hydraulically tiltable cab module
- / Elastic 4-point mount
- / Middle window as a standard

Your advantages

- / Maximum space usage
- / Very good all-round view
- / High level of driving comfort
- / No space lost at the front superstructure wall
- / Vehicle torsional flexibility not restricted

Aluminium technology Integrale



Features

- / Special aluminium cab for appropriate chassis from all manufacturers – connects to the front wall of the superstructure
- / Truck driver's cab remains tiltable, crew module is set
- / Features middle window as a standard

Your advantages

- / Very good all-round view
- / Walk-on crew compartment roof
- / Low driver's cab tilt height
- / Low construction height possible

All-steel technology



Features

- / Crew compartment for IVECO fire-fighting chassis, mounted in series production on the truck assembly line
- / Cataphoretic dipping bath and multi-layered coating
- / Cab hydraulically tiltable and mounted on silent blocks
- / Spacious height and width, large windows, additional middle window

Your advantages

- / Cost-effective solution from a single mould
- / Optimum corrosion protection
- / Much space, very good all-round view
- / No space lost at the front superstructure wall
- / Vehicle torsional flexibility not restricted



# BECAUSE RESPONSIBILITY DOESN'T END WITH PURCHASE: OUR CUSTOMER SERVICE.

With a variety of services, we ensure that fire brigades get perfect service around the clock.

Permanent readiness is a fire brigade's most important task. Magirus customer service thus offers far more than just maintenance and spare parts.



## Maintenance contracts

From the annual inspection to a combined inspection and maintenance contract over a ten-year period, MAGIRUS offers products tailored to the individual requirements of specific fire brigades.



## 12-year warranty against rust through

In conjunction with a maintenance contract and yearly checks, we provide a 12-year warranty against rust through that minimises follow-up costs and provides a reliable basis for calculation.

## Remote diagnostics

The possibility of remote diagnostics to check the condition of vehicles and diagnose sources of malfunction, carry out inspections and correct faults increases availability and helps cut costs.

## Field service

More than 100 Magirus technicians provide on-site customer service. Four central workshops and more than 60 qualified service partners worldwide ensure that you feel looked after.

## Service hotline

Under the hotline number **+49 (0) 731 408 4080**, we are available 24 hours a day, 7 days a week, 365 days a year.

## Spare parts

More than 13,000 different original spare parts are available around the clock. Spare-part documentation ensures fast and secure long-term availability.

## Repairs/General overhauls

We assume comprehensive repairs to your vehicle, e.g. following an accident. And we always bring old vehicles up to the highest standards of today's technology.

## Used vehicles

We offer first-class reconditioned and renovated used vehicles that guarantee uncompromising quality, reliability and technology.



*“In an emergency, we must always be available. Our service partners as well.”*





# PARTNERS SHARE EVERYTHING: INCLUDING KNOWLEDGE AND EXPERIENCE

The purpose of the Fire Fighter Academy is to ensure that fire-fighters get the most out of our vehicles and equipment.

It's one thing to own the latest equipment. Using it to the fullest extent as well as operating it reliably and safely is another. This is what the Fire Fighter Academy is there for. It is the meeting place for everyone who wants the maximum from their Magirus equipment and readiness for new technologies. In addition, the Magirus Fire Fighter Academy is the optimal platform for everyone who wants to expand their know-how and share with colleagues.

As the partners of our customers, we provide our extensive technical and tactical expertise in the Magirus Fire Fighter Academy. It covers operator and driving safety training all the way to courses on tactics and practice missions under real-life conditions. This also means that fire-fighters are trained on their own equipment, get to know it down to the smallest detail as well as master it perfectly. This is not only a valuable contribution to the preservation of value of vehicles and equipment, but also for the safety of each individual in an emergency. Our entire range of courses is structured to capture the enthusiasm of both fire brigade leadership and rank-and-file fire-fighters.









## MAGIRUS FIRE-FIGHTING VEHICLES AND TANK PUMPERS

### MAGIRUS GERMANY

Magirus GmbH  
Graf-Arco-Straße 30  
89079 Ulm  
Germany

Phone +49 731 408-0  
Fax +49 731 408-2410  
E-Mail [magirus@cnhind.com](mailto:magirus@cnhind.com)  
[www.magirusgroup.com](http://www.magirusgroup.com)

### MAGIRUS FRANCE

Magirus Camiva S.A.S.  
689, Avenue de Chambéry  
73230 Saint-Alban-Leysse  
France

Phone +33 479 7566-66  
Fax +33 479 7054-40  
E-Mail [magirus-camiva@cnhind.com](mailto:magirus-camiva@cnhind.com)  
[www.magirus-camiva.fr](http://www.magirus-camiva.fr)

### MAGIRUS ITALY

Iveco S.p.A.  
Stabilimento Mezzi Speciali  
Via Attilio Franchi 23  
25127 Brescia  
Italy

Phone + 39 030 6597-111  
Fax + 39 030 6596-268  
E-Mail [ivecomezzispeciali-i@cnhind.com](mailto:ivecomezzispeciali-i@cnhind.com)  
[www.magirusgroup.com](http://www.magirusgroup.com)

### MAGIRUS AUSTRIA

Magirus Lohr GmbH  
Hönigtaler Straße 46  
8301 Kainbach bei Graz  
Austria

Phone +43 3133 2077-0  
Fax +43 3133 2077-31  
E-Mail [office@magirus-lohr.at](mailto:office@magirus-lohr.at)  
[www.magirus-lohr.at](http://www.magirus-lohr.at)



SERVING HEROES. SINCE 1864.

